

## BG1

Combines attributes of elevating work platforms, order pickers and tuggers in a compact and capable vehicle design.

### CAPACITY

- 1000 lb (454 kg) combined
  - 500 lb (227 kg) front work platform
  - 300 lb (36 kg) operators compartment
  - 200 lb (91 kg) rear "hide away" tray

### BATTERY

- 24-volt battery pack (4) 6V 224 AH AGM maintenance-free batteries
- Built-in 110VAC 15A charger
- Minimum battery weight: 480/590 lb (218/268 kg)
- AH capacity (min/max): 180/255
- Compartment dimensions (open): 26.37" x 8.06"
- Battery compartment rollers
- Connector: SB-175 Grey – A-11

### SPEED

- ZAPI AC-0 travel controller
- EPS AC-0 power steering controller with dashboard display
- Variable from 0 mph to 3.4 mph
- Reduced travel speed at elevation

- **LIFT:** up to 42 fpm

### WEIGHT

- 2,268 lb (1,029 kg) (chassis only)

### TIRES / WHEELS

- **DRIVE:** (1) 9" x 3" polyurethane
- **STABILITY:** (2) 3" x 2" polyurethane
- **LOAD-STEEL HUB:** (2) 8" x 3" polyurethane

### ELECTRICAL

- AC controller manages travel, braking, lift/lower, and steering
- LCD dashboard displays hour meter, battery state, travel speed, and travel direction indicator
- AC drive motor
- Low-maintenance brushless design
- Programmable travel speeds, plugging, and neutral braking are infinitely variable
- Low battery travel lockout

### BRAKES

- Regenerative braking
- Electromagnetic parking brake



### OPERATION / CONTROLS

- Ergonomic fingertip control for travel, lift, and lower functions
- Roomy operator compartment
- Retractable compartment guard rails keep the operator secure
- On/off key switch and horn

### MAST

- Heavy-duty I-beam design
- Steel mast channels and side mounted lift cylinders

### CHASSIS

- Three-point chassis design
- 180° drive motor

### STANDARD EQUIPMENT

- Electronic power steering
- Hide away rear work platform
- Front and rear flashing light

### OPTIONAL EQUIPMENT

- Anchor with tether and harness
- High speed travel
- Tow hitch
- Industrial battery and charger

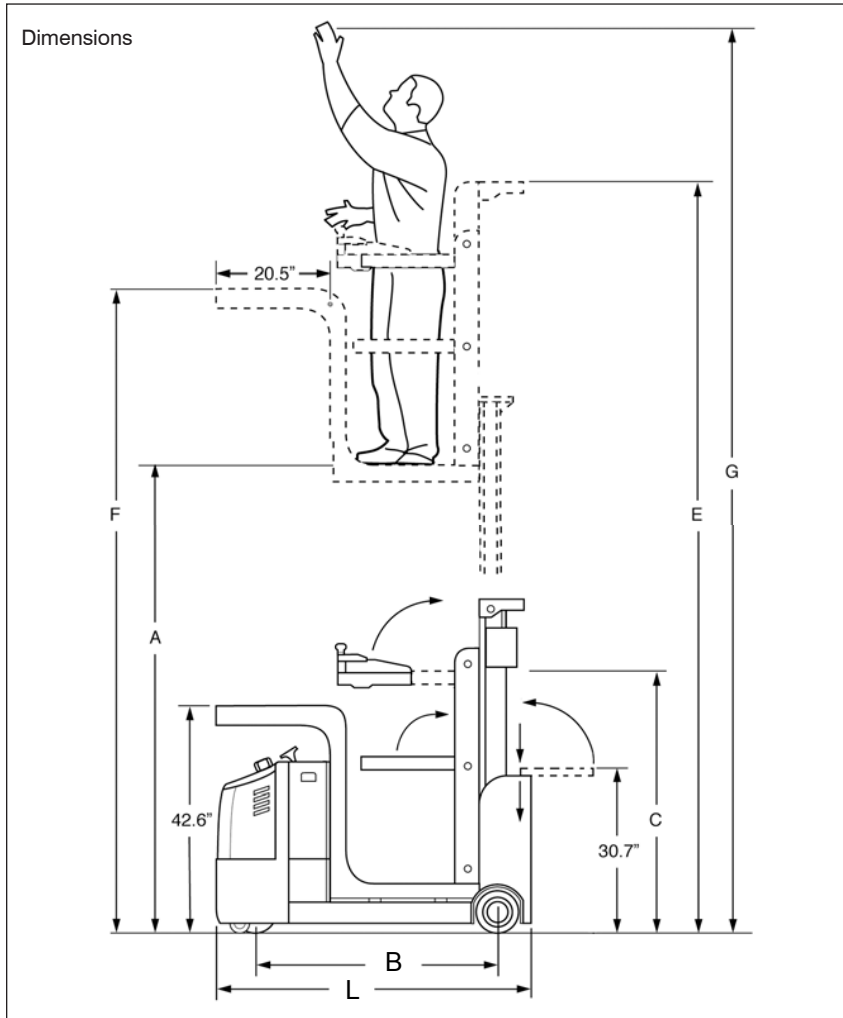

**B Dimension:** BG1-126 and BG1-162 = 45.2", BG1-192 = 49"  
**L Dimension:** BG1-126 and BG1-162 = 59", BG1-192 = 63.25"

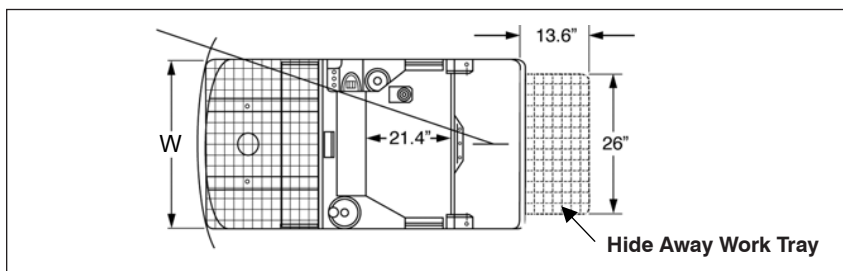

**W Dimension:** BG1-126 and BG1-162 = 31.5", BG1-192 = 34"  
**Turning Radius:** BG1-126 and BG1-162 = 52.5", BG1-192 = 56"

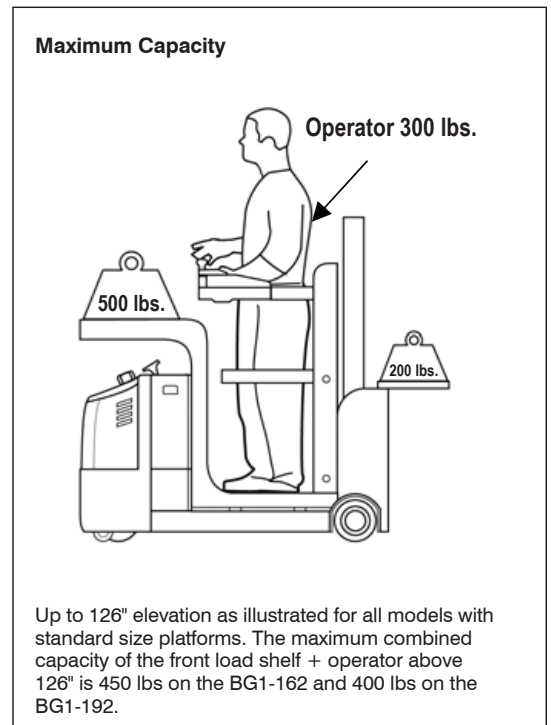
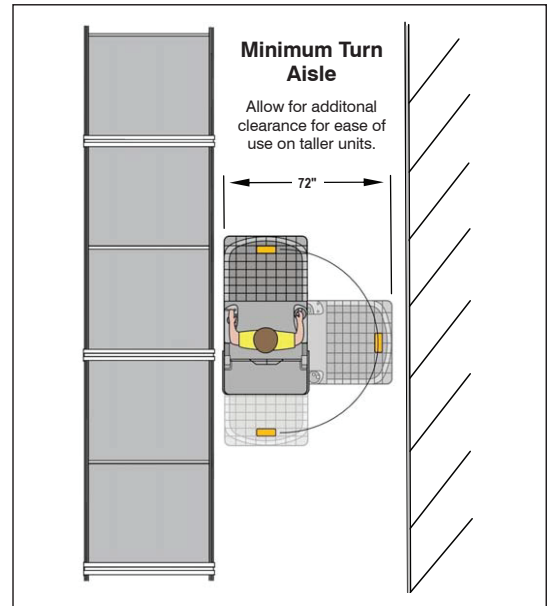

Model#	Mast	Lift Height		Collapsed Height		Extended Height		Load Tray Height		Working Height		Weight (Chassis Only*)	
		A	B	B	C	D	E						
BG1-126	Triple Stage	126"	3,200mm	62.6"	1,590mm	178.6"	4,536mm	159"	4,280mm	203"	5,156mm	2,268 lb	1,029 kg
BG1-162*	Triple Stage	162"	4,115mm	82"	2,045mm	236"	5,451mm	195"	5,197mm	239"	6,071mm	2,610 lb	1,184 kg
BG1-192*	Triple Stage	192"	4,877mm	83"	2,108mm	264"	6,707mm	225"	5,715mm	269"	6,833mm	3,160 lb	1,433 kg

\* Consult factory for derate.

For indoor operation and level surfaces only.

**BLUE GIANT**  
 BLUE GIANT EQUIPMENT CORPORATION

**Corporate** 410 Admiral Blvd  
 Mississauga, ON, Canada L5T 2N6  
 t 905.457.3900 f 905.457.2313

**USA** 6350 Burnt Poplar Road  
 Greensboro, NC 27409  
[www.bluegiant.com](http://www.bluegiant.com)

AUTHORIZED DEALER

Blue Giant offers a full line of dock levelers, dock safety equipment, seals and shelters, accessories, ergonomic and scissor lift equipment and industrial trucks. Concurrent with our continuing product improvement program, specifications are subject to change without notice. Please contact Blue Giant for latest information. Some features illustrated may be optional in certain market areas.