

PART'S LIST

STRONGARM™ TL85 VEHICLE RESTRAINT



WARNING

Do not operate or service this product unless you have read and fully understand the entire contents of this manual. Failure to do so may result in property damage, bodily injury or death.

BLUE GIANT®

13.2 MECHANICAL ASSEMBLY - 51-013732 AND 51-013732-ZP

W

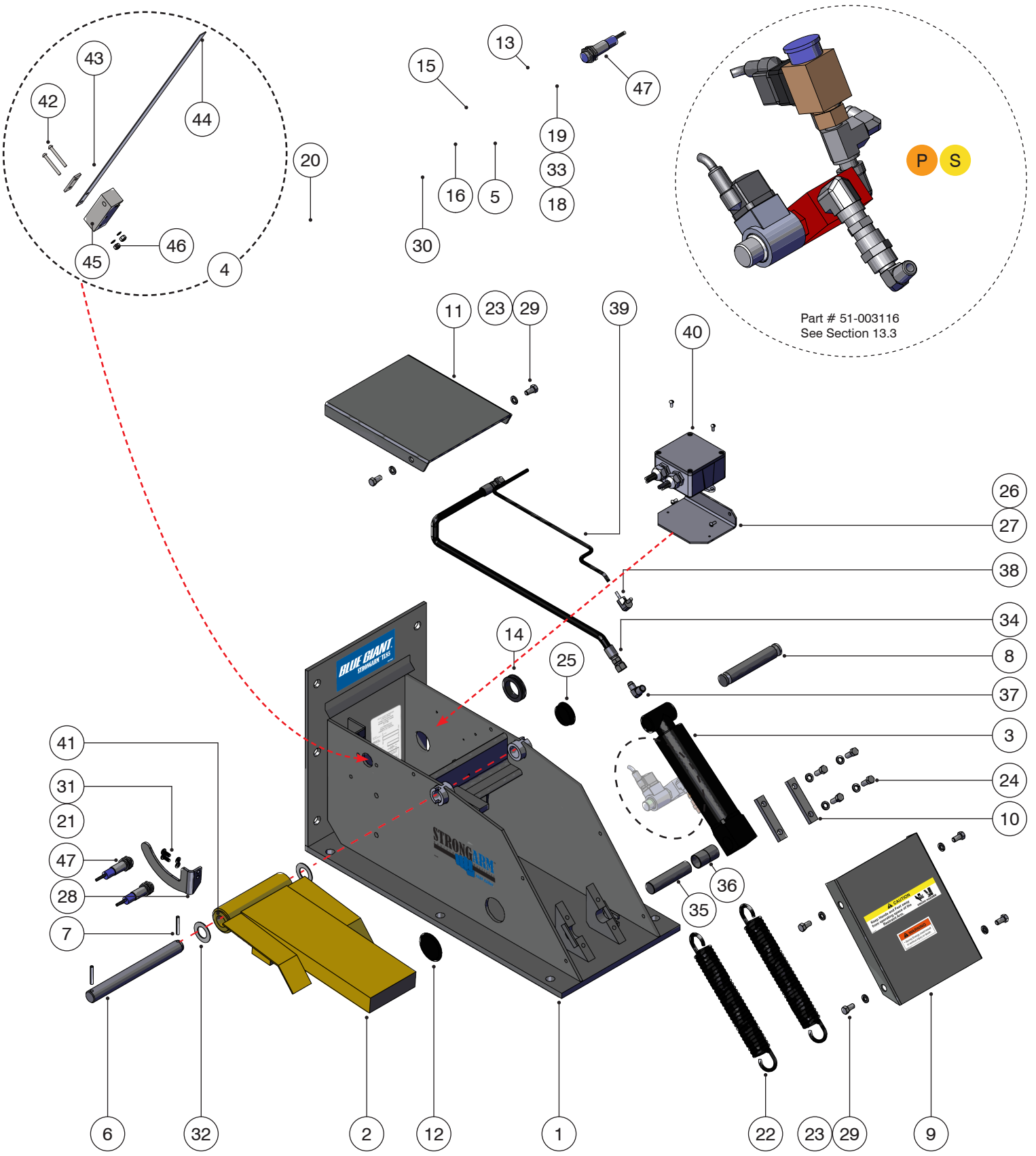

W

MECHANICAL ASSEMBLY - 51-013732 AND 51-013732-ZP CONT'D.

ITEM	QTY	PART NO.	DESCRIPTION
1	1	51-001977	Body Weldment
		51-001977-ZP	Body Weldment, Zinc Plated
2	1	51-012864	Arm Assembly 26" (660 mm) with Bushings
3	1	035-662	Cylinder Assembly 2" dia. (51 mm)
4	1	51-012862	Sensor Wand Assembly
5	1	51-002052	Wand Axle Weldment
6	1	115-099	Hinge Pin
7	2	013-011-1	Spring Pin- SS
8	1	115-094	Spring Holder Pin
9	1	115-100	Front Cover
		115-100-ZP	Front Cover, Zinc Plated
10	2	113-096	Pivot Block Top Plate
11	1	115-103	Top Cover
		115-103-ZP	Top Cover, Zinc Plated
12	1	R3-93002	Plug Button 2" dia. x 1/8" (51 x 3 mm)
13	1	017-085	Extension Spring 1/2" OD x .34" THK x 1 1/4 LNG (13 x 9 x 32 mm)
14	1	037-079	Grommet 1 1/2" x 2 1/8" (38 x 54 mm)
15	1	51-002213	Bearing Square Block
16	1	018-640	Bearing- R10-2RS - ID: 5/8" OD :1 3/8" 11/32" (63 x 40 x 9 mm)
17	1	51-002306	Metallic Spacer
18	1	011-005	Screw Machine R/H slot # 8 - 32 x 1/2" (13 mm)
19	2	011-515	Hex Machine Screw Nut # 8 - 32
20	1	010-154	Hex Bolt 1/4 - 20 UNC X 1 1/4 LNG
21	5	012-202	Regular Lock Washer 0.25
22	2	017-034	Spring Wire OD: 1 5/8" x 1/4" Thick (26 x 6 mm)
23	10	012-201	Regular LW 0.375

ITEM	QTY	PART NO.	DESCRIPTION
24	4	010-039	Hex Bolt 3/8 - 16 UNC X 1 LNG
25	1	037-081	Hole Plug 1 3/4" dia. (44 mm)
26	1	51-002204	Junction Box Bracket
27	4	011-010	SL-RHMS # 10 - 24 x 0.4375
28	1	51-001945	Angular Position Cam
29	6	010-012	Hex Bolt 3/8 - 16 UNC x 3/4 LNG
30	2	010-000	Hex Bolt 0.25 - 20 UNC x 0.75 LNG
31	2	010-215	Machined Screw 1/4 - 20 x 5/8 LG
32	2	106-389	Spacer Washer
33	1	012-206	Flat Washer # 10 OD .5" (13 mm)
34	1	100-5000-41	Hose Assembly # 4 high pressure 22' (6.7 m)*
	1	100-5000-40	Hose Assembly # 4 high pressure 14' (4.3 m)†
35	1	115-307	Cylinder Pin
36	2	018-017	Bushing
37	1	034-511	Fitting, 90 DEG, Elbow *
38	1	040-007	Male Elbow 90 DEG 1/4 tube
39	1	090-909-2400	Tube Polyethylene 20' LG (6.1 m)
40	1	026-H22	TL85 - J-Box Harness* See Sec. 13.10
	1	026-H23	TL85 - J-Box Harness† See Sec. 13.10
41	2	018-013	Bushing, Bronze Oilite Flanged
42	2	011-007	Screw Machine R/H Slot
43	1	116-863	Mounting Block Top Plate
44	1	51-013611	Sensor Wand
45	1	51-002317	Wand Mounting Block
46	2	011-623	Lock Nut 8/32" Nylon Insert
47	3	028-200	Proximity Sensor

* W † P

ARM LOCK AND PRESSURE SWITCH ASSEMBLY - 51-003116

P S

ITEM	QTY	PART NO.	DESCRIPTION
1	1	033-508-24-K	Arm Lowering Valve
2	1	034-567	Fitting, 90 DEG, 3/8 NPT Female, 1/4 NPT Male
3	1	034-698	Fitting, Tee, 1/4 NPT Male, Female, Male
4	1	035-293-A	Pressure Switch
5	1	034-511	Adapter, 90 DEG, 1/4 NPT Male #5 JIC 37 DEG
6	1	034-566	Fitting, Elbow, 1/4 NPT Male, 1/4 NPT Female
7	1	034-507	Fitting, 3/8 NPT Male Straight
8	1	034-522	Female Coupling 3/8 NPT
9	1	034-599	Adapter, Elbow, 1/4 NPT Male, 3/8 NPT Male

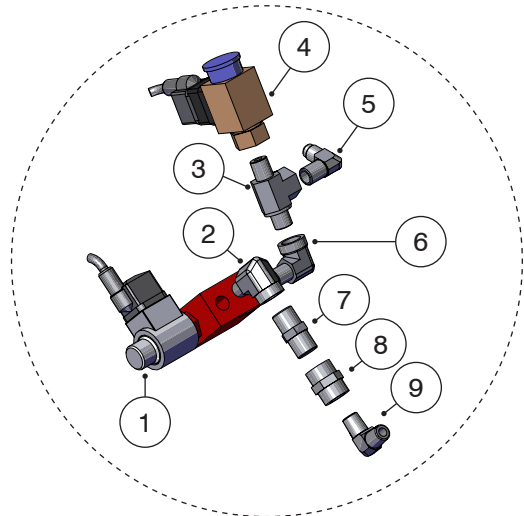

ALTERNATIVE POWERPACK OPTIONS

The TL85 is also available with a self-contained powerpack to suit site conditions.

MECHANICAL ASSEMBLY (SELF-CONTAINED POWERPACK)- 51-013731

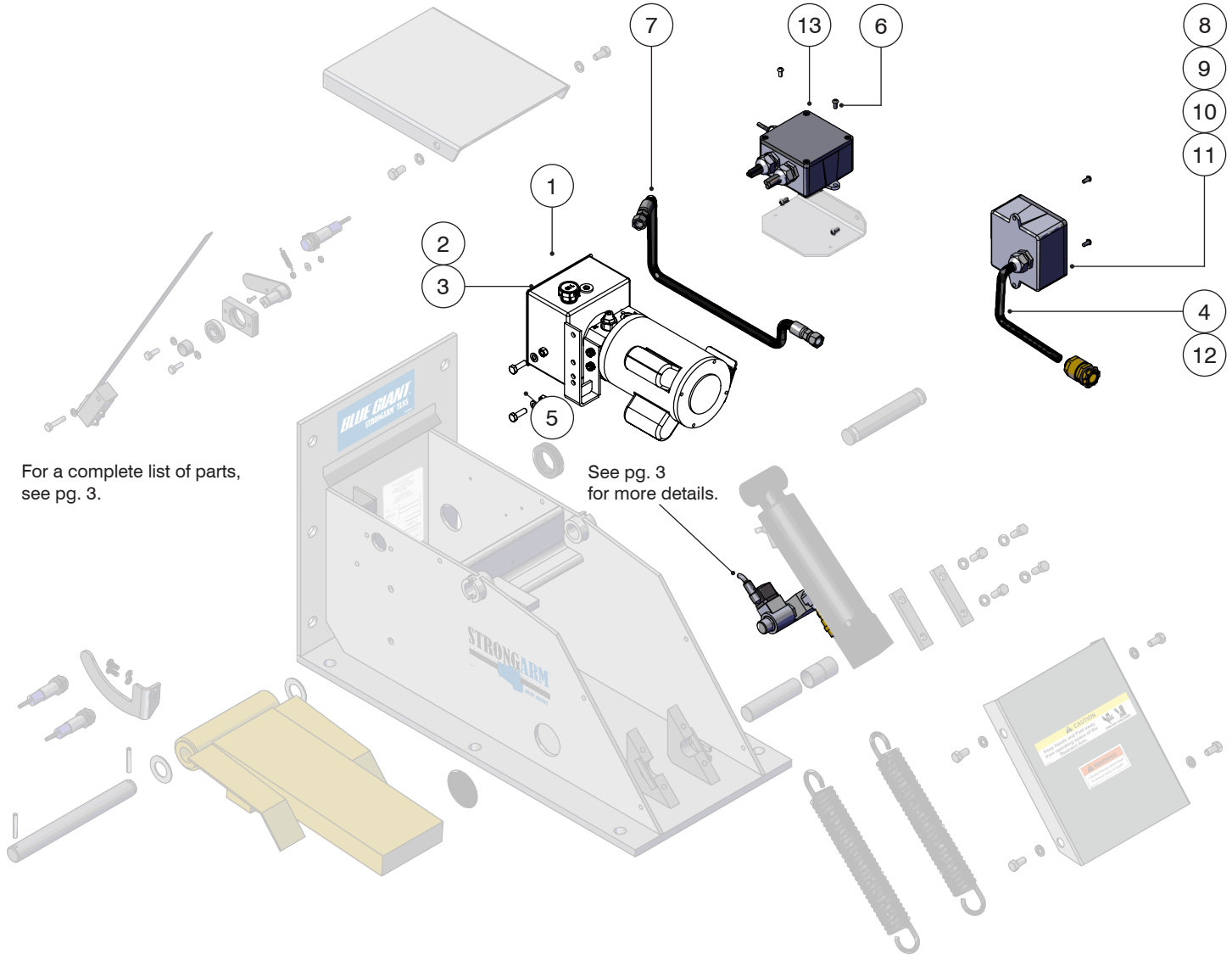

The following items and quantities are unique to the TL85 with self-contained powerpack.

ITEM	QTY	PART NO.	DESCRIPTION
1	1	033-897K	Powerpack, 1PH-115-230V-50-60HZ
		033-899K	Powerpack, 3PH-230-460V-50-60HZ
		033-900K	Powerpack, 3PH-575V-60HZ
2	1	035-436	Tank and Bolts (Included in Item 1)
3		012-200	Washer,Lock,Spq,Regular,5/16,
4	1	026-H07-1	Harness with Cable, 1PH
		026-H08	Harness with Cable, 3PH
5	6	010-006N	Screw,Cap,Hex Hd,5/16-18x1x1,Gr5

ITEM	QTY	PART NO.	DESCRIPTION
6	6	011-010	SL-RHMS #10 - 24 x 0.4375
7	1	100-5000-5	Hose Assembly #4 High Pressure 20" (.5m)
8	1	025-G020-C	Junction Box 4" x 4" (102 x 102 mm)
9	1	025-174	PG16 Cable Gland
10	1	025-177	PG16 Metal Locknut
11	1	025-172	Terminal Strip
12	1	025-016	Fitting SR-50-625 3/4" (19 mm)
13	1	026-H25	J-Box (See Sec. 13.9)

POWERPACK PART IDENTIFICATION - REMOTE WALL-MOUNTED

W

① Full Powerpack Assembly

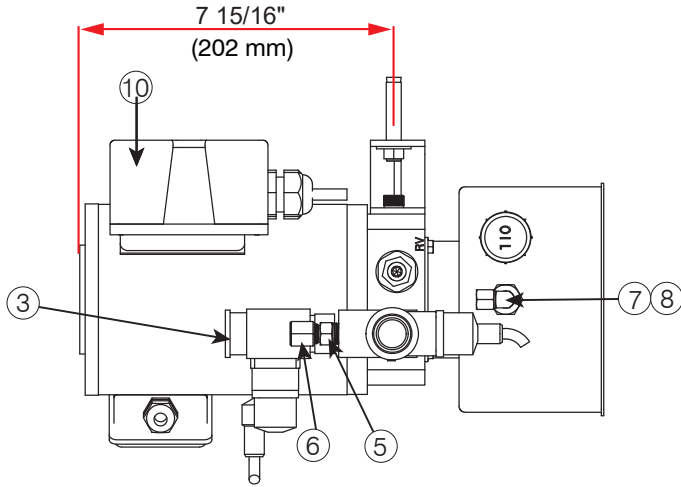

Top View – Wall Mount

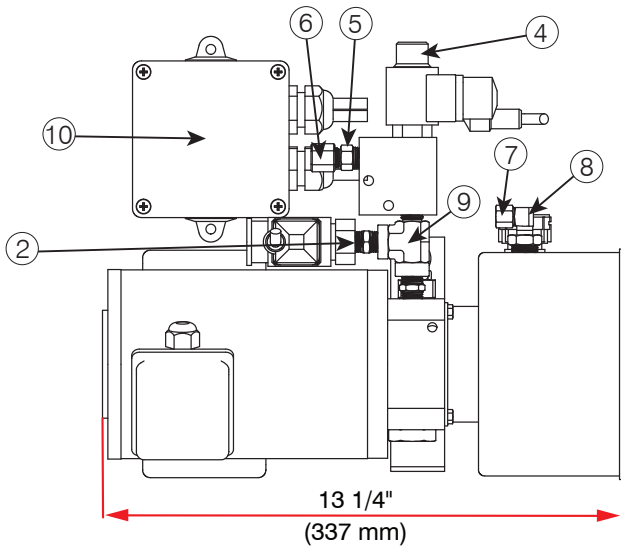

Front View – Wall Mount

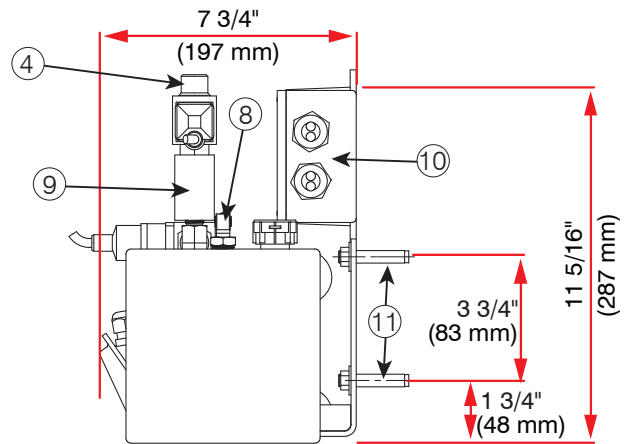

Side View (Tank End) – Wall Mount

TL85 POWERPACK - WALL BRACKET ASSEMBLY # 51-009410					
ITEM	QTY	PART NO.	DESCRIPTION	ITEM #1	
1	1	033-897K	TL85 POWERPACK - Wall	1PH-115-230V-50-60HZ	51-009410-1K
		033-899K		3PH-230-460V-50-60HZ	51-009410-2K
		033-900K		3PH-575V-60HZ	51-009410-3K
		033-897K		1PH-240V-50HZ	51-009410-4K
2	1	033-897-K	Adapter		
3	1	035-293-A	Pressure Switch		
4	1	033-508-24-K	Solenoid Valve, 24V DC Connector		

ITEM	QTY	PART NO.	DESCRIPTION
5	1	034-517	Straight steel adapter
6	1	035-249	Cap nut
7	1	034-726	Reducer bushing
8	1	040-007	Elbow, male, 90 deg for 1/4" dia rigid type tube
9	1	034-574	Fitting-tee
10	1	026-H21	Junction box assembly (see section 13.8)
11	2	010-114	Sleeve anchor (provided by installer)

POWERPACK PART IDENTIFICATION - REMOTE PIT-MOUNTED

① Full Powerpack Assembly

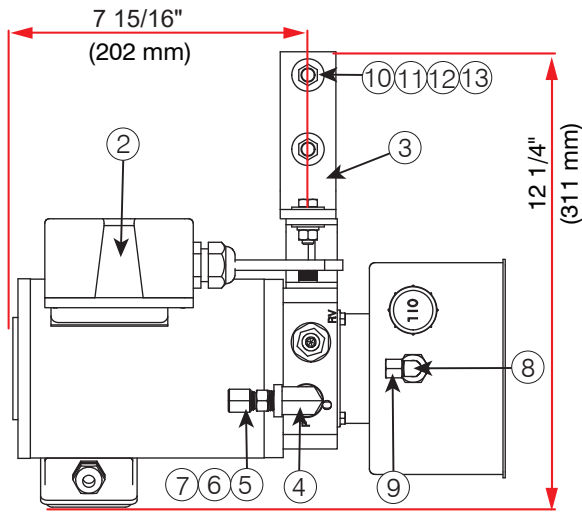

Top View - Pit Mount

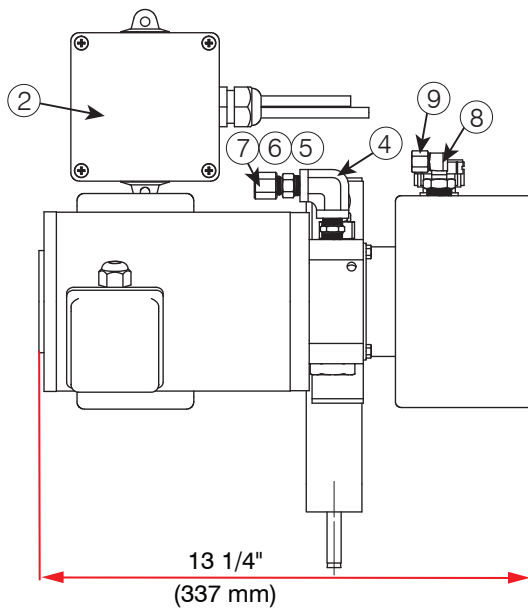

Front View - Pit Mount

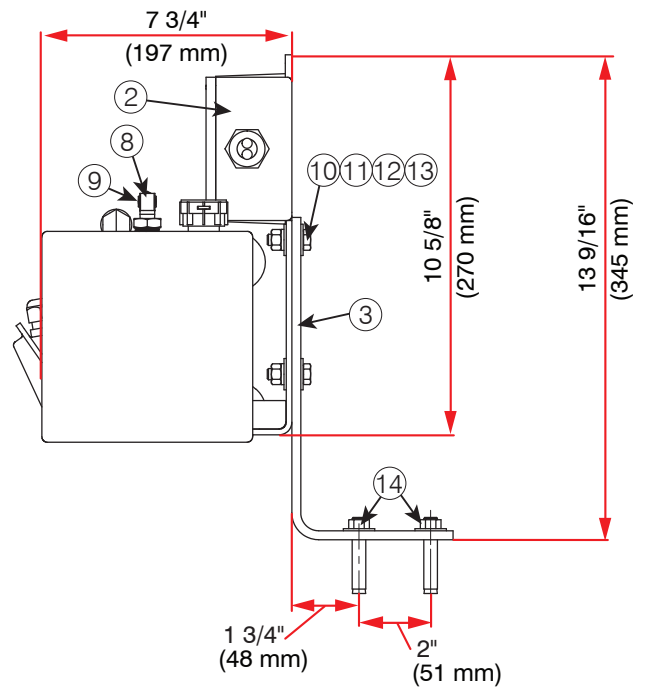

Side View (Tank End) - Pit Mount

TL85 POWERPACK - WALL BRACKET ASSEMBLY # 51-012894					
ITEM	QTY	PART NO.	DESCRIPTION	ITEM #1	
1	1	033-897K	TL85 POWERPACK - Pit	1PH-115-230V-50-60HZ	51-012895-1K
		033-899K		3PH-230-460V-50-60HZ	51-012895-2K
		033-900K		3PH-575V-60HZ	51-012895-3K
		033-897K		1PH-240V-50HZ	51-012895-4K
2	1	026-H25	Junction Box Assembly (See Section 13.9) Note: shipped loosely. Install as required.		
3	1	51-012818	L Bracket		
4	1	034-516	Fitting 90 Deg. Elbow		
5	1	034-560	Adaptor		

ITEM	QTY	PART NO.	DESCRIPTION
6	1	034-517	Straight Steel Adapter
7	1	035-249	Cap Nut
8	1	040-007	Elbow, Male, 90 DEG for 1/4" dia. Rigid Type Tube
9	1	034-726	Reducer Bushing
10	4	012-211	Washer, Flat, Zn Pld, 5/16
11	2	011-502	Nut, Hex, 5/16-18
12	2	012-200	Washer, Lock, Spg, Regular, 5/16
13	2	010-006	Screw, Cap, Hex Hd, 5/16-18x1x1, Gr5
14	2	010-114	Sleeve Anchor (provided by installer)



DECAL IDENTIFICATION AND LOCATION

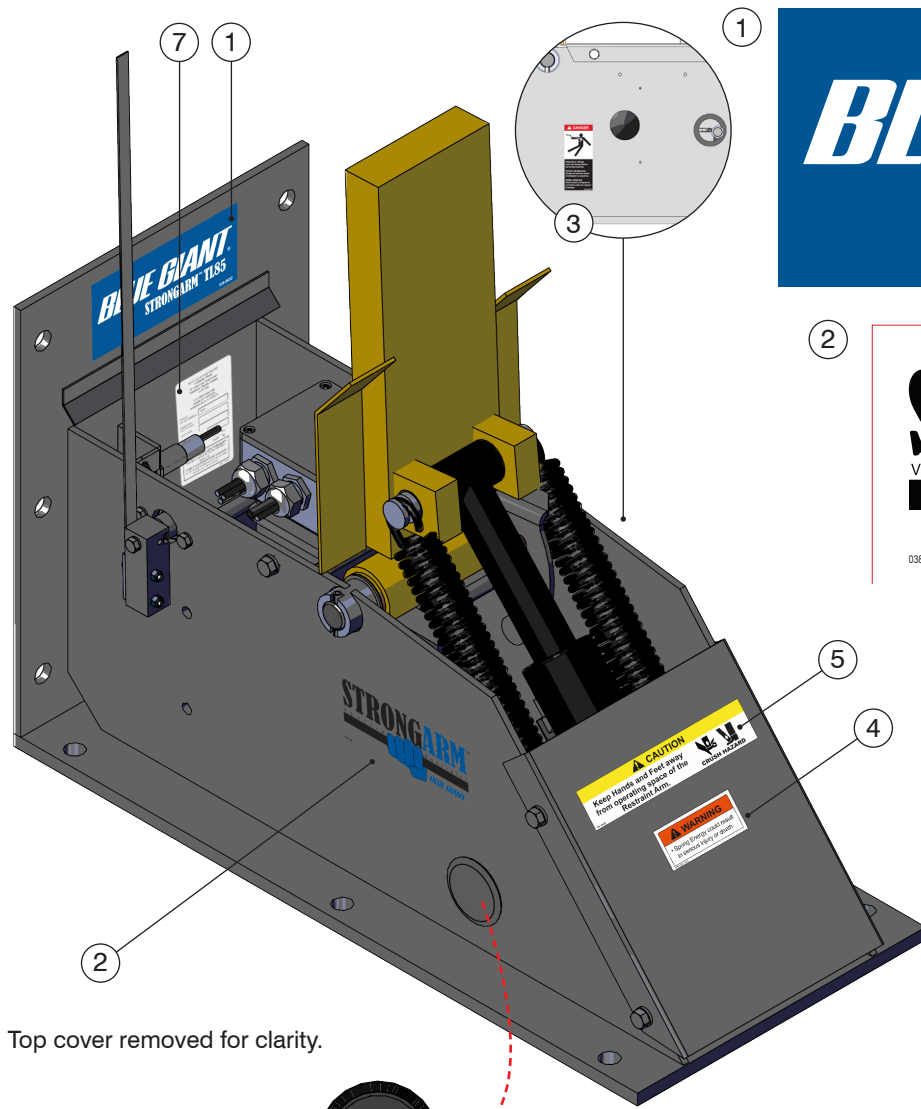

Top cover removed for clarity.

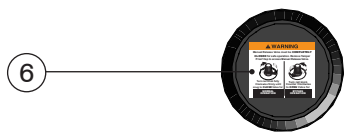

Inside of plug button shown.



ITEM	QTY	PART NO.	DESCRIPTION
1	1	038-863	Decal - BG StrongArm™ TL85
2	2	038-1187E	Decal - StrongArm™ - Vehicle Restraint
3	1	038-084EFS	Warning Decal - Hazardous Voltage
4	1	038-048-2	Warning Decal - Spring Energy
5	1	038-243E	Decal- Crush Hazard
6	1	038-057	Decal - Manual Release Valve
7	1	038-299EF	Decal - Serial Plate - English / French
		038-299ES	Decal - Serial Plate - English / Spanish

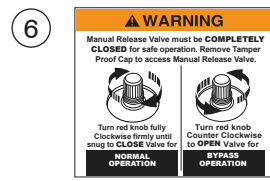

7

BLUE GIANT EQUIPMENT CORPORATION
85 Heart Lake Road South
Brampton, Ontario, Canada
L6W 3K2

www.BlueGiant.com
MADE IN CANADA
FABRIQUE AU CANADA

MODEL / NO. DE MODELE: TL85

SERIAL NO. / NO. DE SERIE: _____

ANSI CODE: _____

CONST. MM / YYYY: _____

TEST LOAD / TEST DE CHARGE: _____ lbs.
_____ kg.

"REFER TO SAFETY AND OPERATING INSTRUCTIONS IN YOUR OWNERS MANUAL" /
"VOIR LES CONSIGNES DE SECURITE ET LE MODE D'EMPLOI DANS VOTRE GUIDE D'UTILISATION."

038-299EF

RECOMMENDED SPARE PARTS - STANDARD OPERATIONAL COMPONENTS

W P S

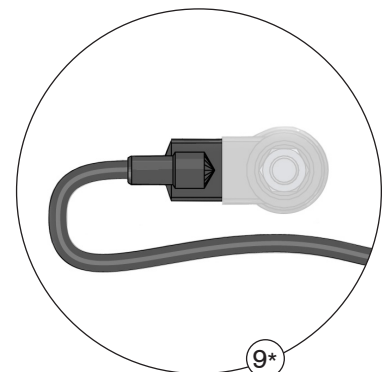
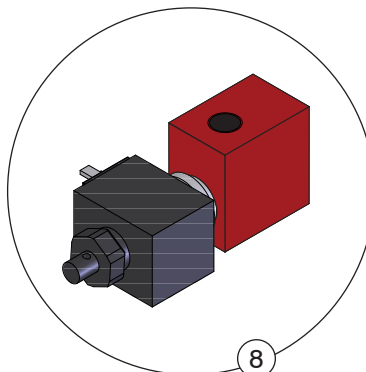
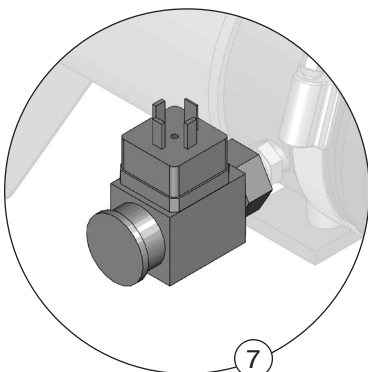
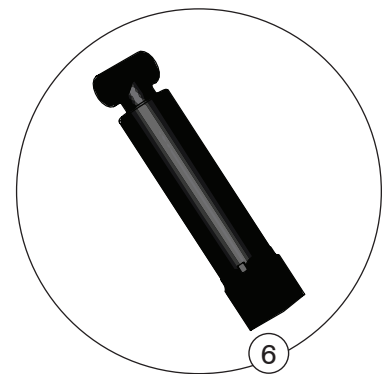
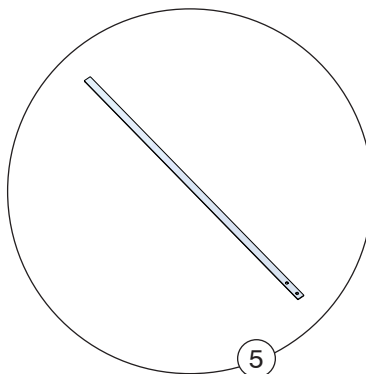
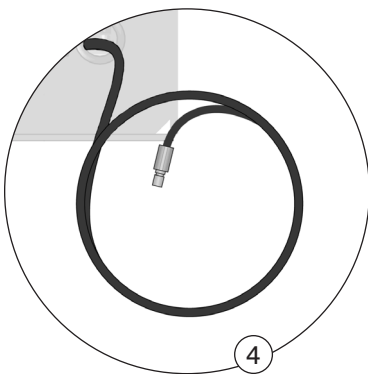
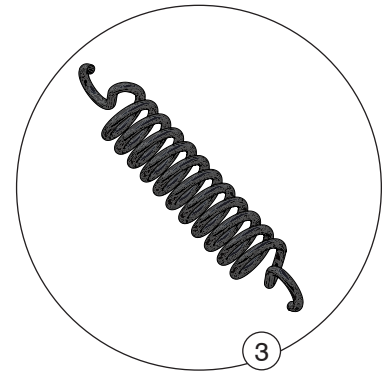
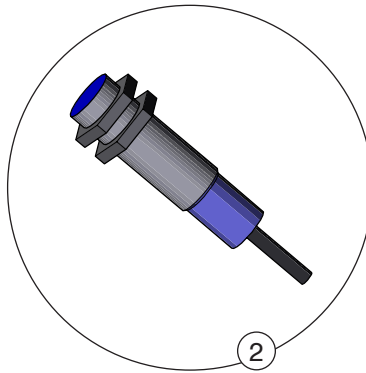
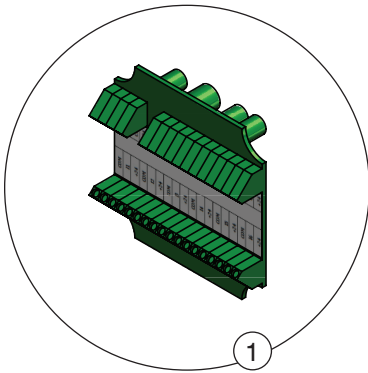

RSP FOR TL85 – STANDARD OPERATIONAL COMPONENTS			
ITEM	PART NO.	DESCRIPTION	QTY REQ'D
1	026-G025M	Remote I/O Board (Resistor)	1
2	028-200	Proximity Sensor, 18 mm	1
3	017-085	Extension Spring, Wand Return	1
4	100-5000-41	Hose Assembly #4 high pressure 22' (6.7m) W	1
	100-5000-40	Hose Assembly #4 high pressure 14' (4.3m) P	
	100-5000-5	Hose Assembly #4 high pressure 20" (.5m) S	

RSP FOR TL85 – STANDARD OPERATIONAL COMPONENTS			
ITEM	PART NO.	DESCRIPTION	QTY REQ'D
5	51-013611	Sensor Wand	1
6	035-662	Cylinder Assembly	1
7	035-293-A	Pressure Switch	1
8	033-508-24-K	Solenoid Valve, Arm Lock Valve with Manual Release	1
9*	026-G074	Solenoid Valve Connector with Cable	1

* Optional



RECOMMENDED SPARE PARTS - COMPONENT SHIELDS

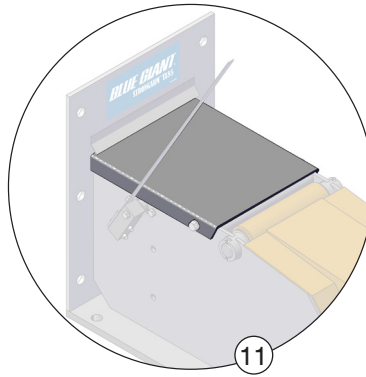
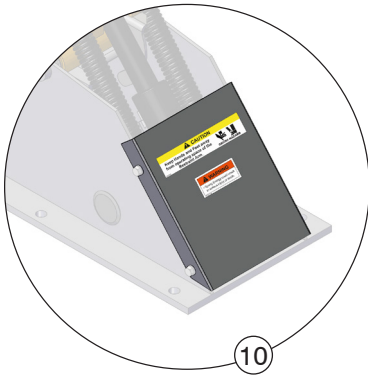

RSP FOR TL85 – COMPONENT SHIELDS			
ITEM	PART NO.	DESCRIPTION	QTY REQ'D
10	115-100	Front Cover	1
	115-100-ZP	Front Cover, Zinc Plated	
11	115-103	Top Cover	1
	115-103-ZP	Top Cover, Zinc Plated	

JUNCTION BOX WITH REMOTE I/O - REMOTE WALL-MOUNTED POWERPACK

TL85 REMOTE I/O HARNESS ASSEMBLY # 026-H21			
ITEM	QTY	PART NO.	DESCRIPTION
1	1	025-G020-1M	Junction Box 4" x 4" (2 Holes)
2	2	025-174	PG16 Cable Gland
3	2	025-177	PG16 Metal Locknut
4	2	025-179	PG16 Multi-Hole Seal (2 Holes)
5	1	026-G025M	Remote I/O Board (Resistor)
6	1	038-279	Circuit Board Decal
7	2	026-G074	Solenoid Valve Connector - 5' (1.52 m)
8	1	026-H16-1	Communication Cable to Blue Genius™ - 30' (9.14 m)
9	1	026-G034-2400	Unshielded Cable #20 AWG - 7 Wire - 20' (6.09 m)

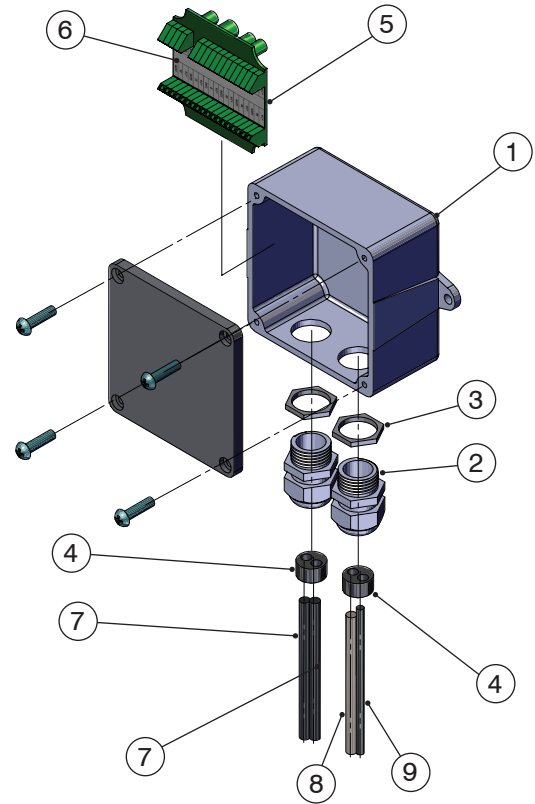

JUNCTION BOX WITH REMOTE I/O - REMOTE PIT-MOUNTED POWERPACK

TL85 REMOTE I/O HARNESS ASSEMBLY # 026-H25			
ITEM	QTY	PART NO.	DESCRIPTION
1	1	025-G020-1N	Junction Box 4" x 4" (3 Holes)
2	2	025-174	PG16 Cable Gland
3	2	025-177	PG16 Metal Locknut
4	2	025-175	PG16 Multi-Hole Seal (3 Holes)
5	1	025-176	PG9 Metal Locknut
6	1	025-173	Cable Gland 2-8mm Range
7	1	026-G025M	Remote I/O Board (Resistor)
8	1	038-279	Circuit Board Decal
9	1	028-199	Proximity Sensor (30mm Unshielded)
10	2	026-G074	Solenoid Valve Connector - 5' (1.52 m)
11	1	026-H16-1	Communication Cable to Blue Genius™ - 30' (9.14 m)
12	3	028-200	Proximity Sensor (18mm Shielded) 10-30V

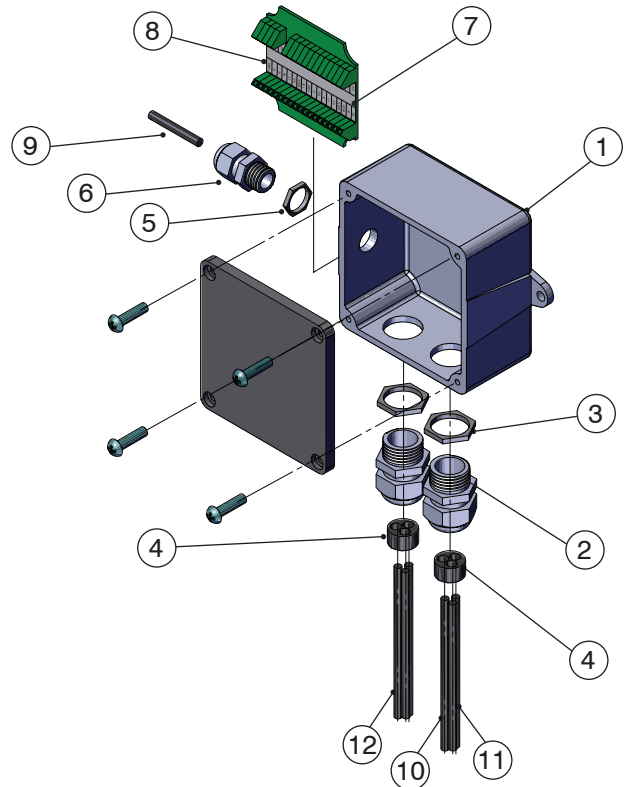

W P

JUNCTION BOX HARNESS

TL85 JUNCTION BOX ASSEMBLY - WALL (IN UNIT) # 026-H22			
ITEM	QTY	PART NO.	DESCRIPTION
1	1	025-G020-1M	Junction Box 4" x 4" (2 Holes)
2	2	025-174	PG16 Cable Gland
3	2	025-177	PG16 Metal Locknut
4	1	025-179	PG16 Multi-Hole Seal (2 Holes)
5	1	025-175	PG16 Multi-Hole Seal (3 Holes)
6	1	025-172	Terminal Strip - 12 Poles
7	1	028-199	Proximity Sensor (30mm Unshielded)
8	3	028-200	Proximity Sensor (18mm Shielded) 10-30V
9	1	026-G034-2400	Unshielded Cable #20 AWG - 7 Wire - 20' (6.09 m)

TL85 JUNCTION BOX ASSEMBLY - PIT (IN UNIT) # 026-H23			
4	-1	025-179	PG16 Multi-Hole Seal (2 Holes)
5	+1	025-172	PG16 Multi-Hole Seal (3 Holes)
9	-1	026-G034-2400	Unshielded Cable #20 AWG - 7 Wire - 20' (6.09 m)
10	+2	026-G074	Solenoid Valve Connector - 5' (1.52 m)

JUNCTION BOX DIMENSIONS

W P S

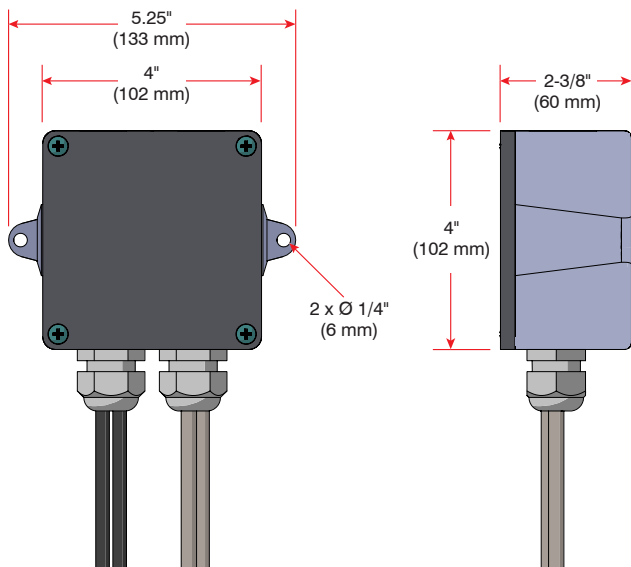

Junction Box - Front View

Junction Box - Side View

TL85 JUNCTION BOX ASSEMBLY - WALL (IN UNIT)

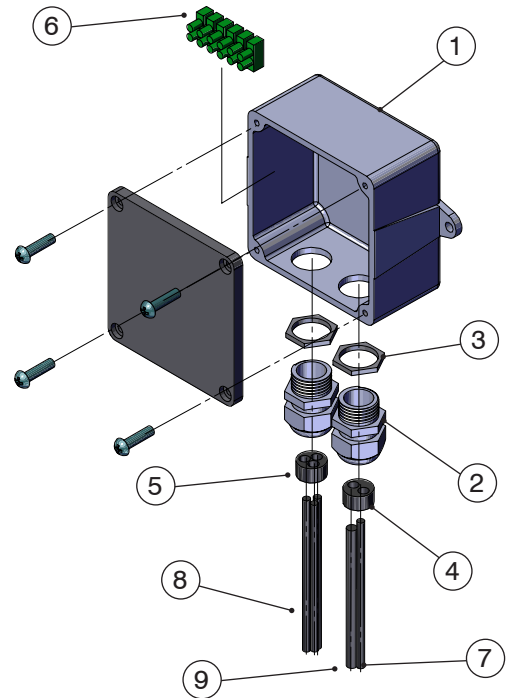

TL85 JUNCTION BOX ASSEMBLY - PIT (IN UNIT)

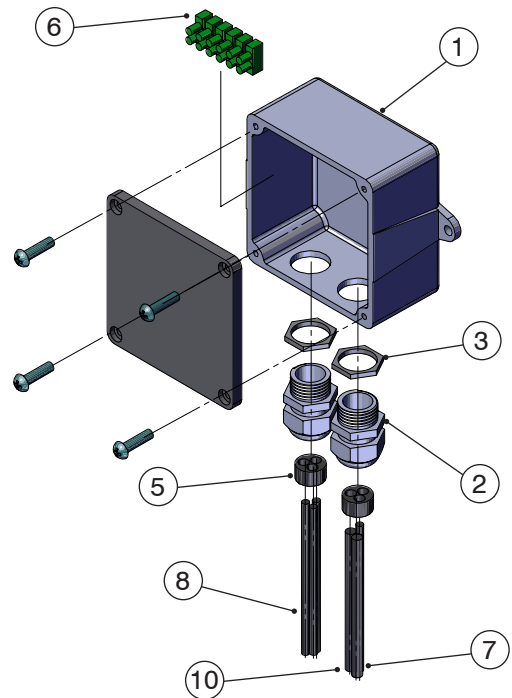

NOTE: 026-H23 contains the same parts and quantity of parts as 026-H22, except where noted by a + or -.

BLUE GIANT[®]
BLUE GIANT EQUIPMENT CORPORATION

Corporate 410 Admiral Blvd.
Mississauga, ON, Canada L5T 2N6
t 905.457.3900 f 905.457.2313

USA 6350 Burnt Poplar Road
Greensboro, NC 27409
www.bluegiant.com