

PARTS LIST

VERTICAL STORING DOCK LEVELER WITH BLUE GENIUS™ TOUCH CONTROL



ACTUAL PRODUCT MAY NOT APPEAR EXACTLY AS SHOWN



WARNING

Do not operate or service this product unless you have read and fully understand the entire contents of this manual. Failure to do so may result in property damage, bodily injury or death.

BLUE GIANT®

MECHANICAL ASSEMBLY

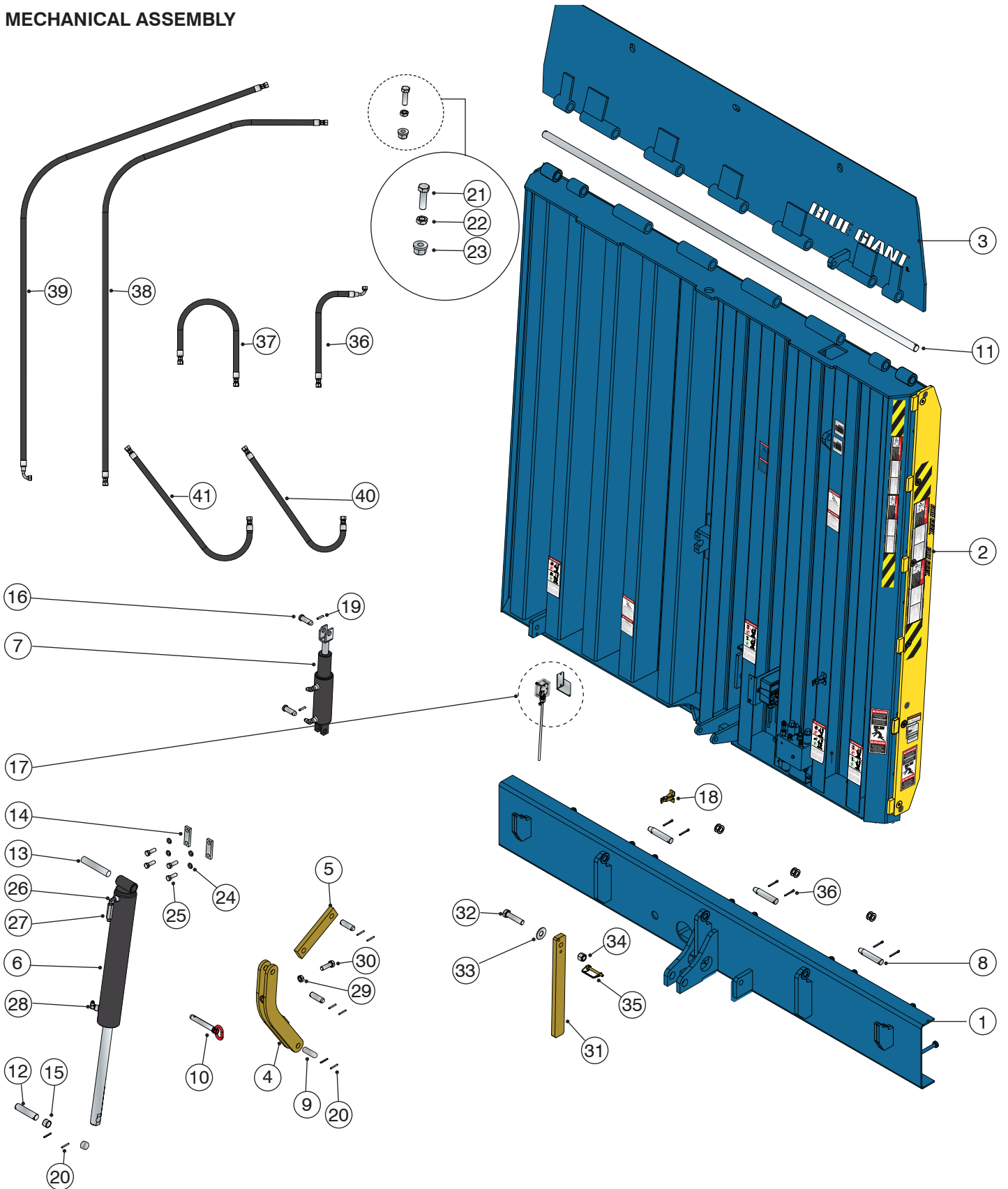

MECHANICAL ASSEMBLY CONT'D.

ITEM	QTY	PART NO.	DESCRIPTION
1	1	See Owner's Manual (038-1121E)	Back Frame Weldment
2	1	See Owner's Manual (038-1121E)	Deck Weld
3	1	See Owner's Manual (038-1121E)	Lip Plate Weldment
4	1	1000847-1	Service Stand
5	1	1000839	Service Stand - Top Link
6	1	23-014490	Deck Cylinder Assembly - 2" Cushion
7	1	213-5058-1	Lip Cylinder Assembly, Double Acting
8	3	2013770	Pivot Pin
9	3	23-012803-1	Pivot Pin
10	1	013-077	Lock Pin
11	1	See Sec. 13.2	Shaft
12	1	23-012717-1	Cylinder Pin Rod
13	1	090-189-0054	Pin
14	2	23-003568	Clevis Plate
15	2	018-121	Bushing
16	2	107-196	Clevis Pin
17	1	23-013313	Inclinometer Assembly
	1		Bracket
	2	011-159	Self-tapping Screws 1/4"
18	1	013-537	Tool Holder - Zinc Plated - 5/8" - 7/8" dia.
19	2	013-010	1/4" dia. Spring Pin 1.25" long

ITEM	QTY	PART NO.	DESCRIPTION
20	14	013-127	3/16" dia. Spring Pin x 1.50" long
21	2	010-060	HHCS 5/16-18 UNC x 1 GR.5 ZN
22	2	012-200	Regular Spring Lock Washers 5/16" (U.S.)
23	2	011-530	Hex Nuts (U.S.)
24	4	012-220	Regular Spring Lock Washers (U.S.)
25	4	011-075	HHCS 1/2-13 UNC x 1-1/2"
26	1	034-599	Fitting 90 6MP - 4MP
27	1	033-661	Velocity Fuse
28	1	034-601	Fitting
29	1	011-527	Hex Jam Nut
30	1	010-066	Screw Cap HHCS 5/8-11, GR.5
31	1	2015275-1	Maintenance Strut for 12" Pit
		2015275-2	Maintenance Strut for 15" Pit
32	1	010-086	Screw Shoulder 3/4 x 1-3/4" long
33	1	012-214	Flat Washers (U.S.) 3/4"
34	1	011-535	Flange Hex. Locknut 3/4" - 10
35	1	013-078	Linch Pin - 3/8" dia. x 2-1/4" Usable
36	6	013-025	Cotter Pin, 3/15x1 1/2

		HOSE ASSY. - #6 HIGH PRESSURE		RUN TO WALL - 18' (5.5m)		RUN TO POST - 9' (2.7m)	
ITEM	DECK LENGTH	DESCRIPTION		PART NO.	ACTUAL SIZE	PART NO.	ACTUAL SIZE
36	6' (1.8m)	Deck	Raise	300-5005-7	35" L	300-5005-7	35" L
37			Lower	300-5000-21	48" L	300-5000-21	48" L
38		Lip	Extend	300-5000-19	30" L	300-5000-19	30" L
39			Return	3000-5005-7	35 L	3000-5005-7	35 L
40	Deck Mounted Powerpack Only	Powerpack T (Tank) Line		2016140		2016140	
41		Powerpack P (Power) Line		300-5005-16		300-5005-16	
36	8' (2.4m)	Deck	Raise	300-5005-7	35" L	300-5005-7	35" L
37			Lower	300-5000-21	48" L	300-5000-21	48" L
38		Lip	Extend	300-5000-49		300-5000-49	
39			Return	300-5005-9		300-5005-9	
40	Deck Mounted Powerpack Only	Powerpack T (Tank) Line		300-5000-15		300-5000-15	
41		Powerpack P (Power) Line		300-5000-18		300-5000-18	

Run = Backframe to powerpack

POWERPACK PART IDENTIFICATION

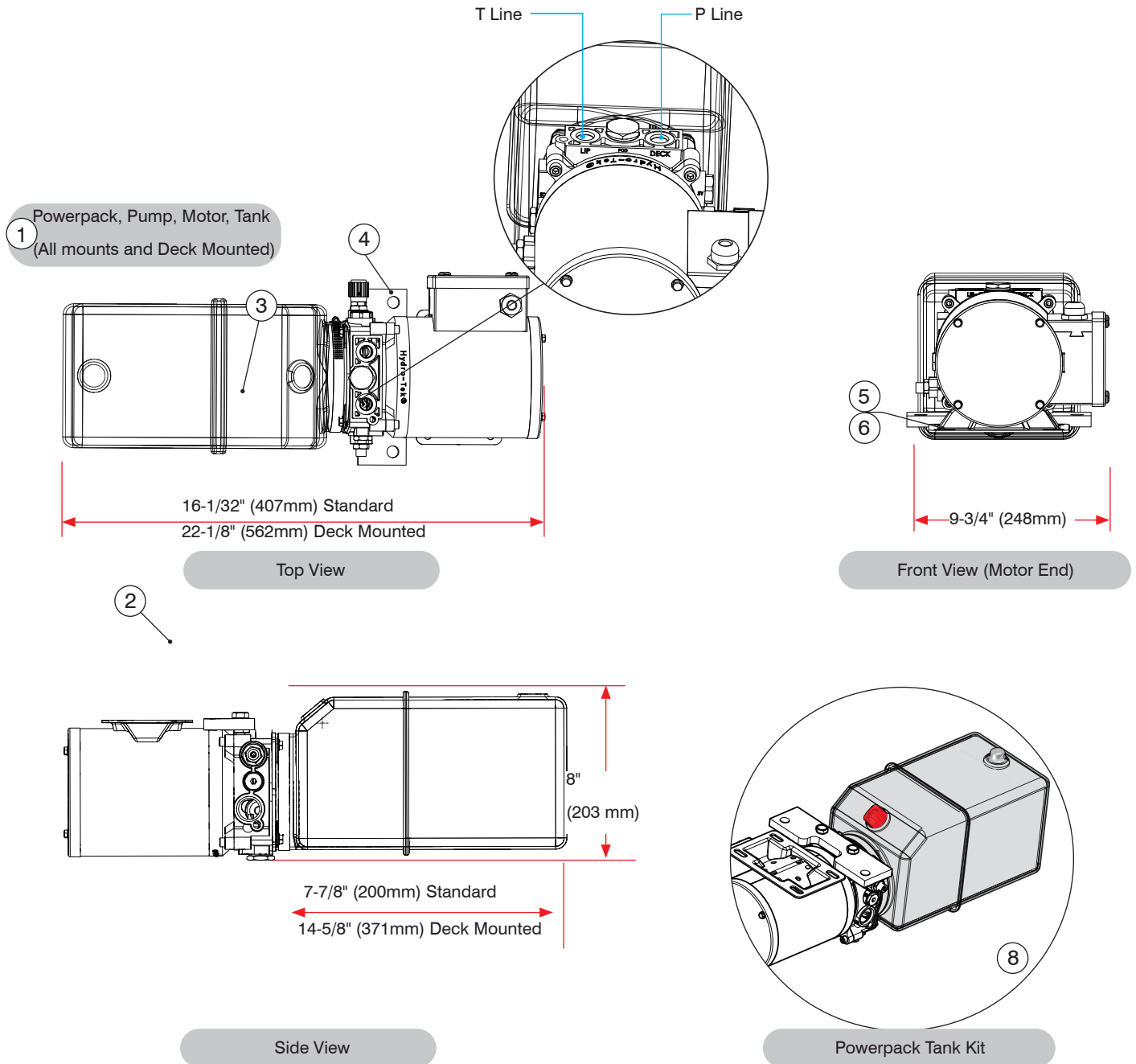

VERTICAL DOCK POWERPACK ASSEMBLY			
Standard Powerpack			
ITEM	QTY	PART NO.	DESCRIPTION
1	1	033-461-K	PPACK - REMOTE 1PH-115V-230V-60HZ
		033-462-K	PPACK - REMOTE 3PH-230/460V-60HZ
		033-463-K	PPACK REMOTE 3PH-575V-60HZ
5	—	OPT-V-DOCK- _OIL	Hydraulic Oil Options

VERTICAL DOCK POWERPACK ASSEMBLY			
Deck Mounted Powerpack Only (Deck Mounted Powerpack = Standard + Kit)			
ITEM	QTY	PART NO.	DESCRIPTION
2	1	035-471	Tank
3	1	2014317	Wall Bracket (Deck Mounted Only)
4	1	010-170	Hex Head Cap Screws M10x20
5	—	OPT-V-DOCK- _OIL	Hydraulic Oil Options

MANIFOLD PART IDENTIFICATION

1 Manifold

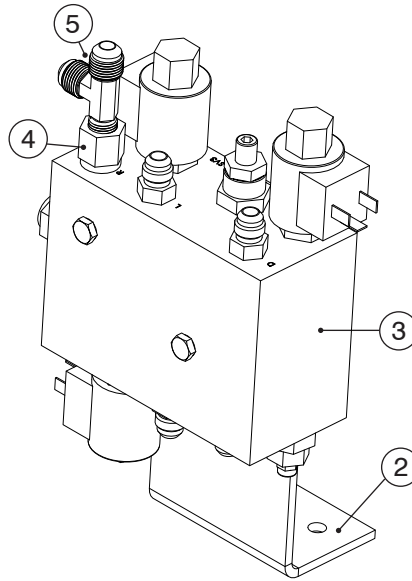

Bottom View

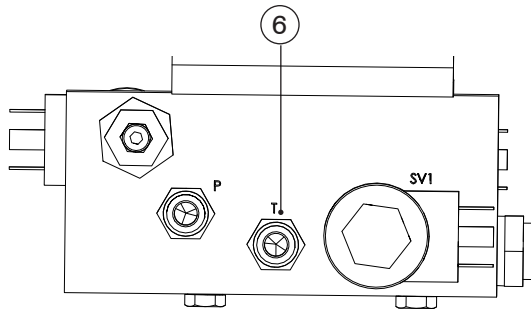

Top View

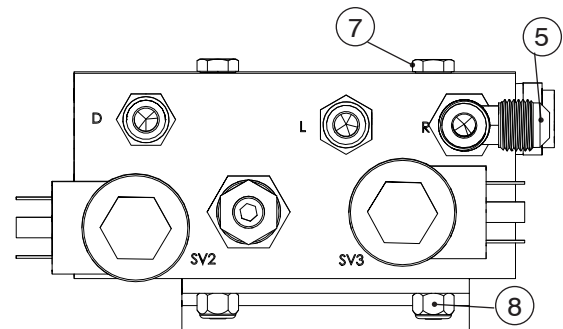

VERTICAL DOCK MANIFOLD ASSEMBLY # PART NUMBER			
ITEM	QTY	PART NO.	DESCRIPTION
1	1	2014215	Manifold Assembly
2	1	2013691	Manifold Mounting Bracket
3	1	2014213	Vertical Dock Manifold
4	1	034-508	3/6 Fem. Pipe to male O-ring
5	1	034-665	Fitting Tee #6
6	4	034-621	Straight #6 to O-ring #6
7	2	010-197	1/4-20x3x0.75, GR5, NP Screw Cap
8	2	011-545	Hex Nut Nylon Lock 1/4-20 Preferred

VERTICAL DOCK WITH BLUE GENIUS™ CONTROL—PARTS LIST

CONTROLS

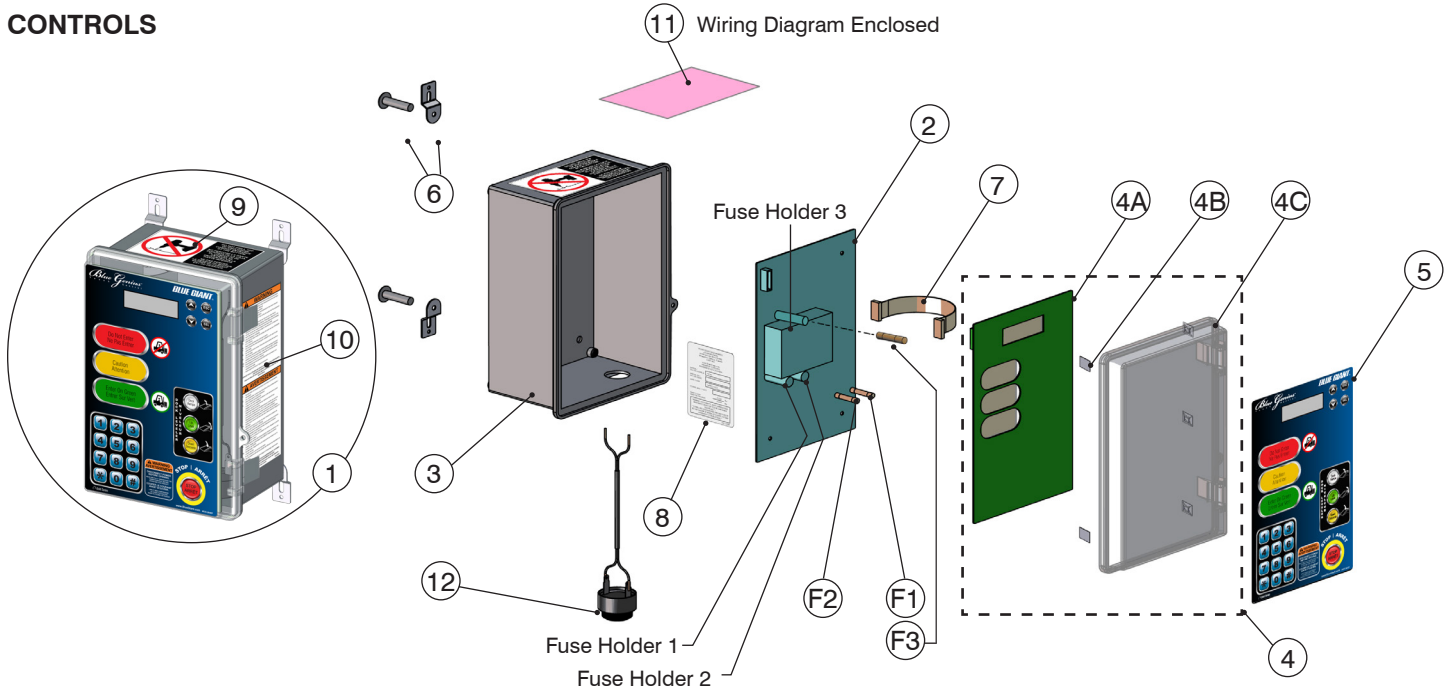

COMPLETE CONTROL STATION ASSEMBLY - ITEM 1 (Example BGG0V1115F)							ITEM	QTY	PART NO.	DESCRIPTION	
2	SINGLE PHASE						6	1	025-G010-1	Mounting Tabs with Hardware (1 pkg of 4)	
	◇	FUSE	QTY	PART NO.	DESCRIPTION	ASSY PART #	*	7	026-G030	Ribbon Cable	
	F1	A	1	026-PB1115-FH	Power Board Sub-Assembly † (1PH 115V 50-60HZ)	BGG0V1115	F	8	038-284E	F	Decal, Serial Plate
	F2	E	1				S			S	
	F1	C	1	026-PB1230	Power Board Sub-Assembly † (1PH 230V 50-60HZ)	BGG0V1230	F	9	038-283EFS	F	Decal, Do Not Drill
	F2	C	1				S			S	
	THREE PHASE						11	1	026-615-1	Anti-Static Poly Bag (Wiring Diagram Enclosed) (Serial # required for diagram)	
	◇	FUSE	QTY	PART NO.	DESCRIPTION	ASSY PART #	*	12	026-G028	Audible Speaker	
	F1	C	1	026-PB3230	Power Board Sub-Assembly † (3PH 230V 50-60HZ)	BGG0V3230	F	F3	026-037-1	F	AS PER VOLTAGE - SEE ITEM 1
	F2	C	1				S			S	
	F1	F	1	026-PB3400	Power Board Sub-Assembly † (3PH 400V 50-60HZ)	BGG0V3400	F	AS PER VOLTAGE - SEE ITEM 1			
	F2	F	1				S				
	F1	G	1	026-PB3460	Power Board Sub-Assembly † (3PH 460V 50-60HZ)	BGG0V3460	F	ITEM	QTY	PART NO.	DESCRIPTION
	F2	G	1				S	A	1	026-G100	Fuse, 15A, 250V , Time Delay for 1PH, 110-130V
F1	H	1	026-PB3575	Power Board Sub-Assembly † (3PH 575V 60HZ)	BGG0V3575	F	B	1	026-G101	Fuse, 8A, 250V, Time Delay for 1PH, 208-240V	
F2	H	1				S	C	1	026-G102	Fuse, 0.5A, 250V, Time Delay for 1 and 3PH, 208-240V	
3		1	025-G010-M	Control Box Enclosure (Includes 4C)			D	1	026-G103	Fuse, 0.25A, 250V, Time Delay for 1PH, 208-240V	
4		1	025-G014-V3-M	Transparent Cover Door (4C) and Touch Control Board (4A) (Serial # Required)			E	1	026-G104	Fuse, 0.75A, 250V, Time Delay for 1PH, 110-130V	
4A		1	026-G021-M	Touch Control Board (Serial # Required)			F	1	026-G105	Fuse, 500mA, 700V, Fast Acting for 3PH, 380-415V	
4B		5	025-062	Cable Tie Mount			G	1	026-G106	Fuse, 400mA, 700V, Fast Acting for 3PH, 440-480V	
4C		1	025-G014	Transparent Cover Door			H	1	026-G107	Fuse, 315mA, 700V, Fast Acting for 3PH, 575-600V	
5		1	038-264E	Button Decal							

* Language on decal: F = English / French S = English / Spanish

◇ Location on Power Board † Includes Fuses ‡ 115 Volt Control Box Shown

STANDARD REMOTE I/O

STANDARD REMOTE I/O PART # 026-H28			
ITEM	QTY	PART NO.	DESCRIPTION
1	1	025-G020-M	Junction Box 4" x 4"
2	2	025-174	PG16 Cable Gland
3	2	025-177	PG16 Metal Locknut
4	1	025-179	PG16 Multi-Hole Seal - 2 Holes
5	1	025-175	PG16 Multi-Hole Seal - 3 Holes
6	1	026-G025BM	Remote I/O Board (No Resistor)
7	1	038-279	Circuit Board Decal
8	3	026-G074	Solenoid Valve Connector - 5' (1.5 m)
9	1	026-H16-1	Communication Harness with cable - 30' (9.1 m)
10	1	026-H01-1	Communication Cable - 3 Wire - 20' (6 m)

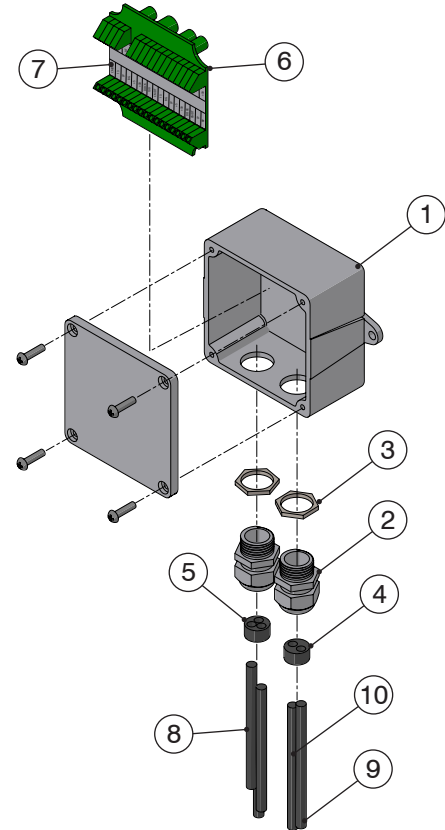

OPTIONAL DOOR REMOTE I/O

OPTIONAL DOOR REMOTE I/O PART # 70-0020			
ITEM	QTY	PART NO.	DESCRIPTION
1	1	110-404	Junction Box
2	1	026-G025-99	Remote I/O Board (Door Control)
3	1	025-173	PG9 Cable Gland
4	1	025-176	PG9 Metal Locknut
5	1	025-174	PG16 Cable Gland
6	1	025-177	PG16 Metal Locknut
7	1	025-175	PG16 Multi-Hole Seal - 3 holes
8	1	026-G031-C	Communication Cable Shielded - 15' (4.5 m)

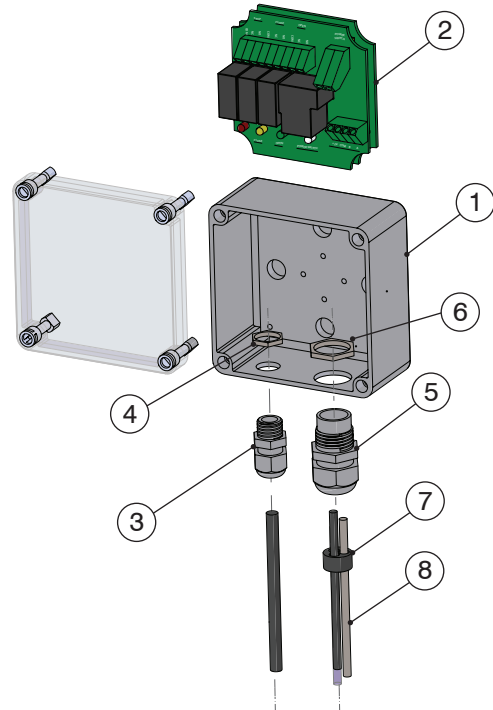

DECAL IDENTIFICATION AND LOCATION

7 **⚠ DANGER**

Do not remove the release pin from the safety stand unless authorized personnel have confirmed that the hydraulic cylinders, valves and hoses have been properly installed and filled with fluid. Failure to do so will result in serious injury or death. Refer to Owner's Manual for proper procedure.

Ne pas retirer le piquet de déchargement du support de sécurité, sauf si les personnes autorisées ont confirmé que les cylindres hydrauliques, vannes et les hoses ont été installés correctement et remplis d'huile hydraulique. Ne pas le faire peut entraîner une blessure grave ou la mort. Consultez le manuel de propriétaire pour les procédures appropriées.

8 **⚠ DANGER**

Do not remove the lockout pin from the maintenance area unless authorized personnel have confirmed that the hydraulic cylinders, valves and hoses have been properly installed and filled with fluid. Failure to do so will result in serious injury or death. Refer to Owner's Manual for proper procedure.

Ne pas retirer le piquet de verrouillage de la zone de maintenance, sauf si les personnes autorisées ont confirmé que les cylindres hydrauliques, vannes et les hoses ont été installés correctement et remplis d'huile hydraulique. Ne pas le faire peut entraîner une blessure grave ou la mort. Consultez le manuel de propriétaire pour les procédures appropriées.

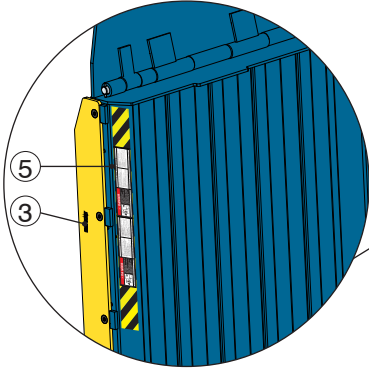

6 **⚠ DANGER**

CRUSH HAZARD

Do not stand between the dock and the truck. Do not stand between the dock and the truck when the dock is being lowered. Do not stand between the dock and the truck when the dock is being raised. Do not stand between the dock and the truck when the dock is being lowered. Do not stand between the dock and the truck when the dock is being raised. Do not stand between the dock and the truck when the dock is being lowered. Do not stand between the dock and the truck when the dock is being raised.

RISQUE D'ÉCRASEMENT

Ne pas se tenir entre le dock et le camion. Ne pas se tenir entre le dock et le camion lorsque le dock est abaissé. Ne pas se tenir entre le dock et le camion lorsque le dock est relevé. Ne pas se tenir entre le dock et le camion lorsque le dock est abaissé. Ne pas se tenir entre le dock et le camion lorsque le dock est relevé. Ne pas se tenir entre le dock et le camion lorsque le dock est abaissé. Ne pas se tenir entre le dock et le camion lorsque le dock est relevé.

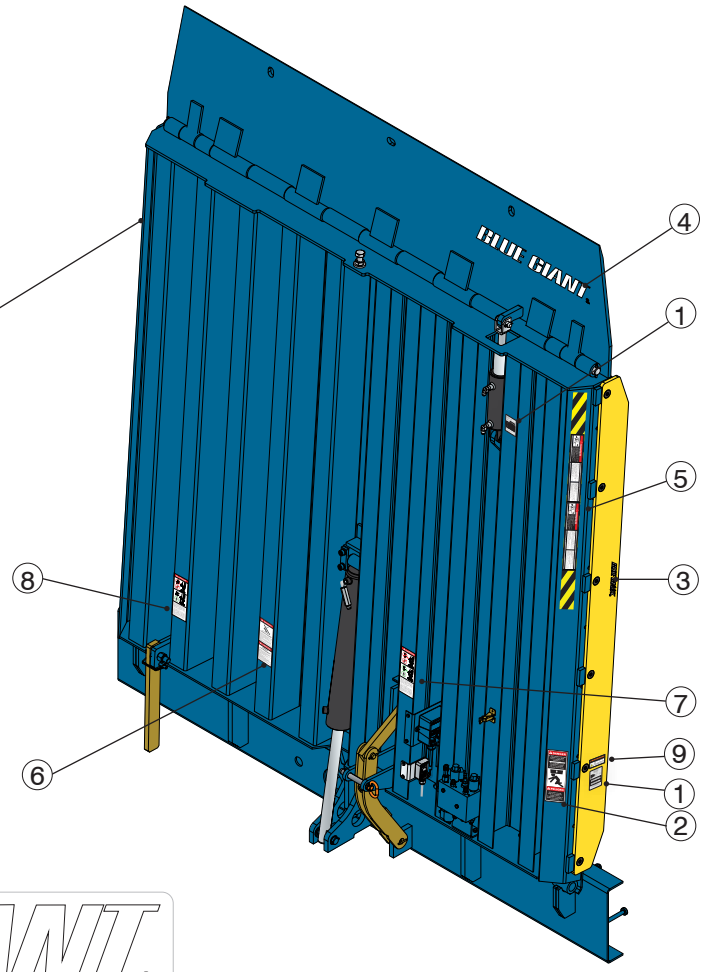

5 **⚠ DANGER**

SAFETY INSTRUCTIONS

OPERATION

1. Read and follow all instructions and warnings in user's manual.
2. Use of dock leveler restricted to trained operators.
3. Always chock trailer wheels or engage trailer restraint before operating dock leveler or beginning to load or unload.
4. Never use hands or equipment to move ramps or lip.
5. Before activating dock leveler:
 - Ensure trailer is backed in against bumpers.
 - Remove any and all loads if required.
 - Check trailer alignment to avoid lip interference. If lip does not lower to trailer bed, reposition vehicle.
 - Ensure truck bed supports extended lip or leveler frame supports ramp before driving on ramp.

MAINTENANCE SERVICE

1. Read and follow all instructions, warnings and maintenance schedules in user's manual.
2. Maintenance/service of dock leveler restricted to trained personnel.
3. Place barriers on driveway and dock floor to show service work is being performed.
4. DO NOT ENTER PIT unless dock leveler is securely supported by maintenance strut.
5. If electrically powered turn off and use OSHA lockout/tagout procedures.

Failure to follow posted instructions will result in death or serious injury. Call 1-(800)668-7078 for replacement placards, warning labels, or user's manual.

UNsupported dock leveler ramps can lower unexpectedly. Before allowing vehicle to leave the dock, always:

- Ensure no equipment, material or people are on dock leveler.
- Return dock leveler to its stored position at dock level.

Un niveauur s'abaisse de façon inattendue. Avant de permettre au véhicule de quitter le quai, toujours:

- S'assurer qu'aucun matériel, matériel ou personne n'est sur le niveauur.
- Retourner le niveauur à sa position de repos au niveau du quai.

Un défaut de suivre ces instructions peut causer la mort ou de graves blessures.

ITEM	QTY	PART NO.	DESCRIPTION
1	2	108-120	Decal - Serial Plate
		EF	
		ES	
2	2	038-230EFS	Decal - Danger Do Not Stand
3	2	038-218	Decal - Blue Giant - Large
4	1	038-219	Decal - Blue Giant - Small
5	2	038-226	Decal - Danger Safety Instructions
		EF	
		ES	
6	1	038-308	Decal - Vertical Dock Crush Hazard
		EF	
		ES	
7	1	038-309	Decal - Danger Safety Stand Operation
		EF	
		ES	
8	1	038-310	Decal - Danger Maintenance Strut Operation
		EF	
		ES	
9	1	038-109	Decal - Prop65 CancerReproductive
		ES	

1 **WORKHORSE** BLUE GIANT EQUIPMENT CORPORATION
www.bluegiant.com

MODEL / MODELLE SERIAL NO. / NO. DE SERIE
ELECTRICS / ALIMENTATION

USAGE / LOAD CYCLES (DAILY)

WEIGHT (lb) (kg)	0-8	9-16	17-24	>24
0-300	✓	✓	✓	✓
301-600	✓	✓	✓	Consult / Consulter
601-1000	✓	✓	✓	Consult / Consulter
>1000	✓	✓	✓	Consult / Consulter

10 YEAR MINIMUM LIFE EXPECTANCY / 10 ANS D'ESPÉRANCE DE VIE MINIMALE
MAXIMUM STATIC DISTRIBUTION LOAD / CHARGE DE DISTRIBUTION STATIQUE MAXIMALE: 50,000 LB / 22,680 kg

MODIFICATIONS OUTSIDE OF THOSE OUTLINED IN PRODUCT DOCUMENTATION SHALL NOT BE PERFORMED WITHOUT THE MANUFACTURER'S WRITTEN APPROVAL. REFER TO SAFETY AND OPERATING INSTRUCTIONS IN YOUR OWNER'S MANUAL.

COMPLIES WITH / CONFORME AVEC ISO 9001

038-108ZF MADE IN CANADA

2 **⚠ DANGER**

Do NOT stand on this side of dock leveler. Dock leveler swings down toward you.

Ne restez PAS sur ce côté du quai niveauur. Le niveauur de quai s'abaisse vers l'avant.

⚠ PELIGRO

NO se pare en este lado del nivelador de muelle o andén. El nivelador de muelle o andén abre hacia abajo y hacia usted.

038-230EFS

RECOMMENDED SPARE PARTS

STANDARD OPERATIONAL COMPONENTS

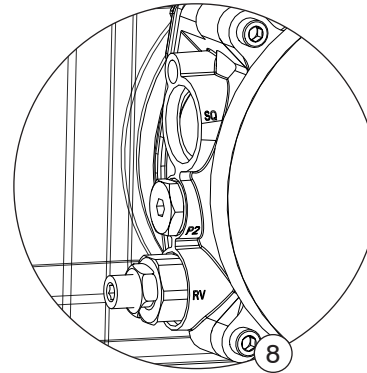
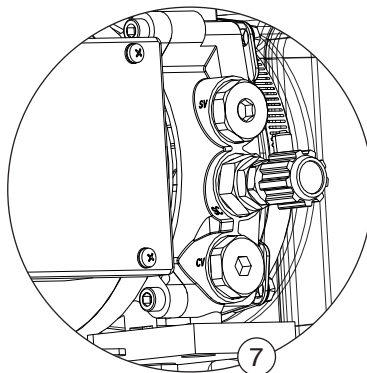
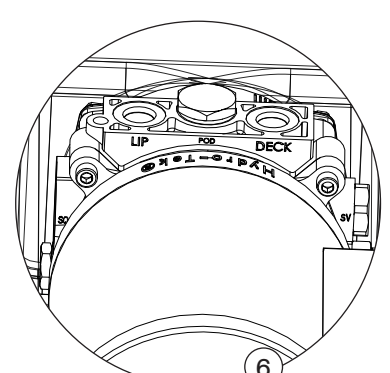
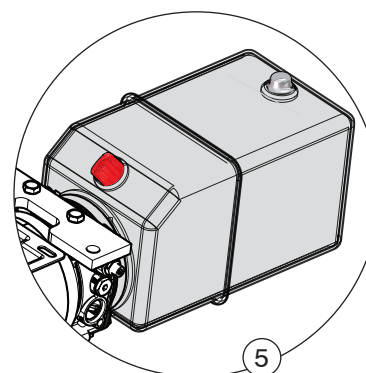
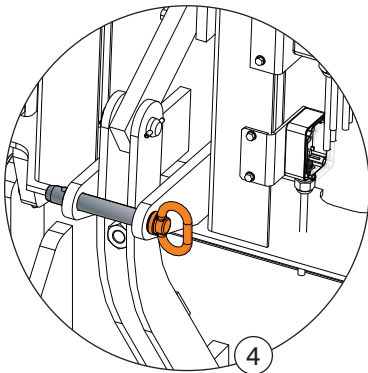
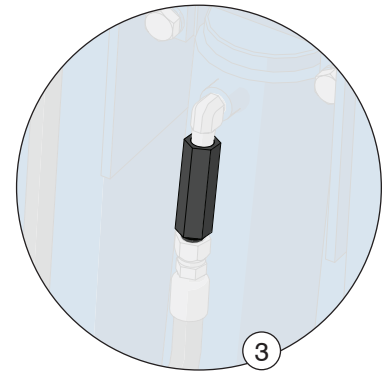
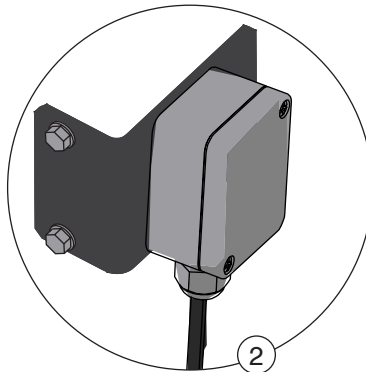
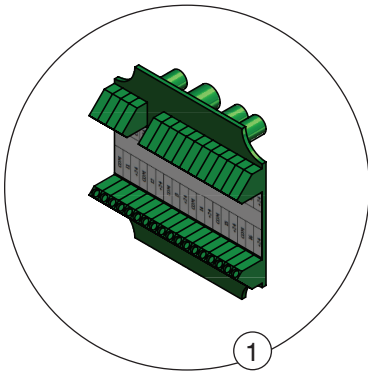

RSP FOR DOCK – STD OPERATIONAL COMPONENTS			
ITEM	PART NO.	DESCRIPTION	QTY REQ'D
1	026-G025BM	Remote I/O Board (No Resistor)	1
2	026-G024-A	IntelliTilt™ Sensor Assembly	1
3	033-661	Velocity Fuse	1
4	013-077	Safety Stand Lock Pin w/ Ball Plunger	1
5	080-510	Reservoir Kit - Vertical Dock Powerpack	1
6	—	Lip (T Line)and Deck (P Line) Hydraulic Lines	1

RSP FOR DOCK – STD OPERATIONAL COMPONENTS			
ITEM	PART NO.	DESCRIPTION	QTY REQ'D
7	—	SV	—
		CV	
		SC	
8	—	SQ	—
		P2	
		RV	

STANDARD OPERATIONAL COMPONENTS CONT'D.

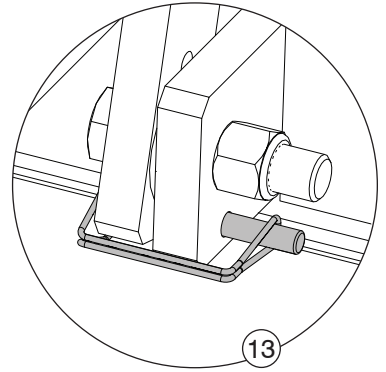
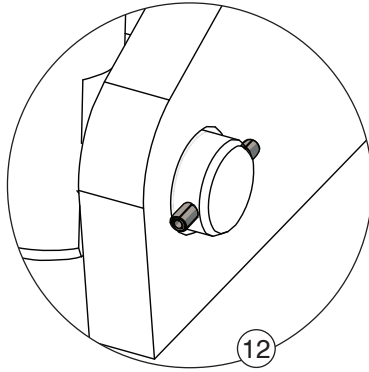
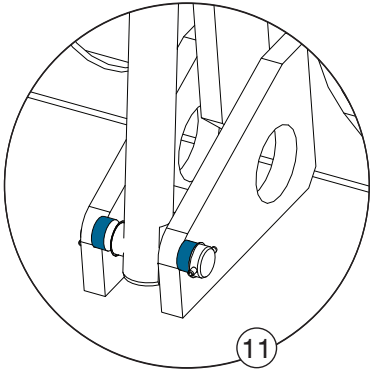

RSP FOR DOCK – STD OPERATIONAL COMPONENTS

ITEM	PART NO.	DESCRIPTION	QTY REQ'D
11	018-121	Bushings	2
12	013-127	3/16" Dia. Spring Pin x 1.50	8
13	013-078	Linch Pin 3/8" Dia. x 2-1/4" Usable	1

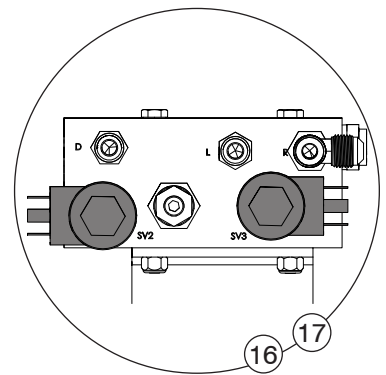
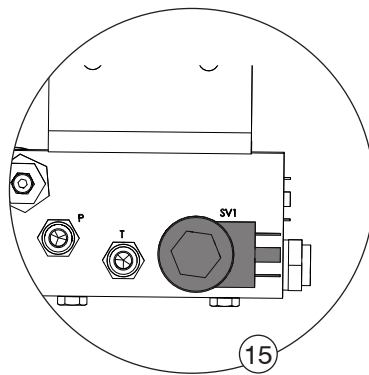
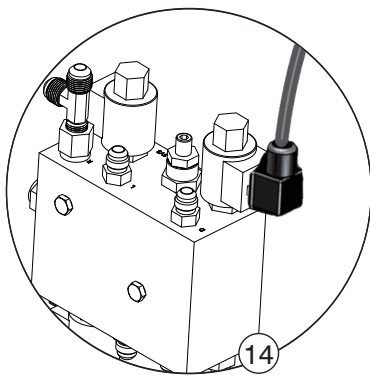

RSP FOR Dock – STD OPERATIONAL COMPONENTS

ITEM	PART NO.	DESCRIPTION	QTY REQ'D
14	026-G074	Solenoid Valve Connector with Cable	1
15	Please contact your Blue Giant Dealer.	SV1 Kit	1
16		SV2 Kit	1
17		SV3 Kit	1

OPTIONAL SUPPORT COMPONENTS

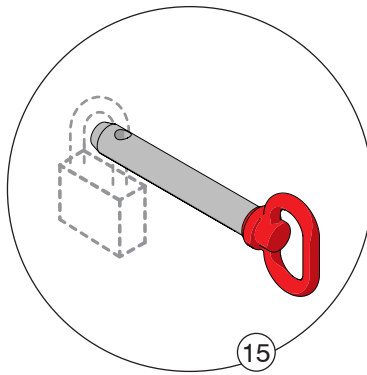
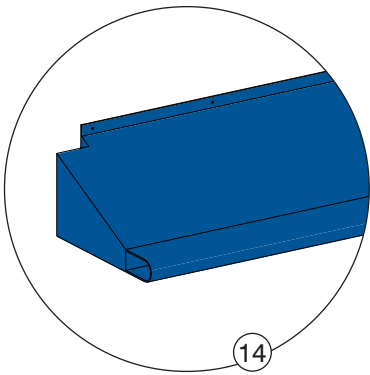

RSP FOR Vertical Dock (OPTIONAL)			
ITEM	PART NO.	DESCRIPTION	QTY REQ'D
14	2014527-1	Draft Pad (72" Door Width)	1
	2014527-2	Draft Pad (78" Door Width)	
	2014527-3	Draft Pad (83" Door Width)	
15	013-092	Lock-out/Tag-out Safety Stand Pin	1

OPTIONAL EXTERIOR TRAFFIC LIGHT / MIRROR IMAGE SIGN

The LED traffic lights and mirror image drive warning sign improve loading dock safety.

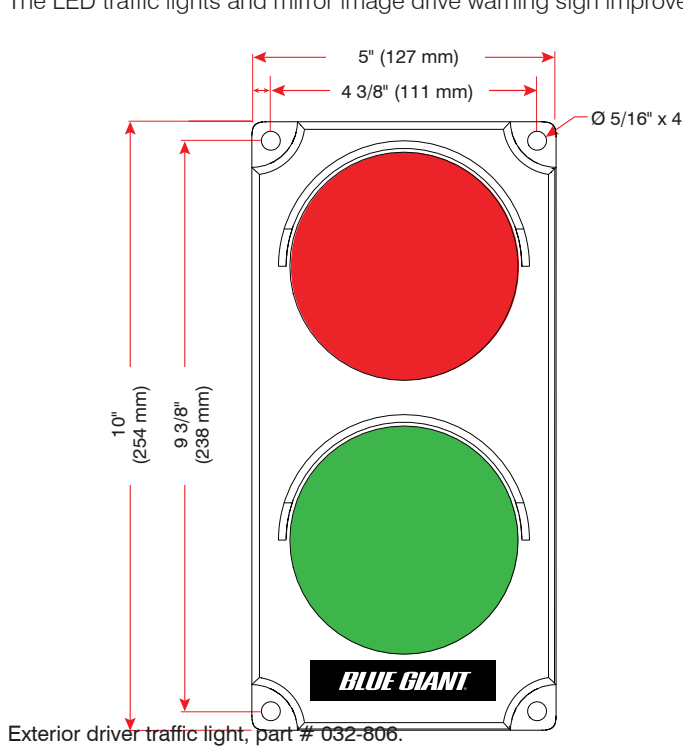

Exterior driver traffic light, part # 032-806.

NOTE: Mount to a flat surface. DO NOT deform light housing with irregular wall surface.

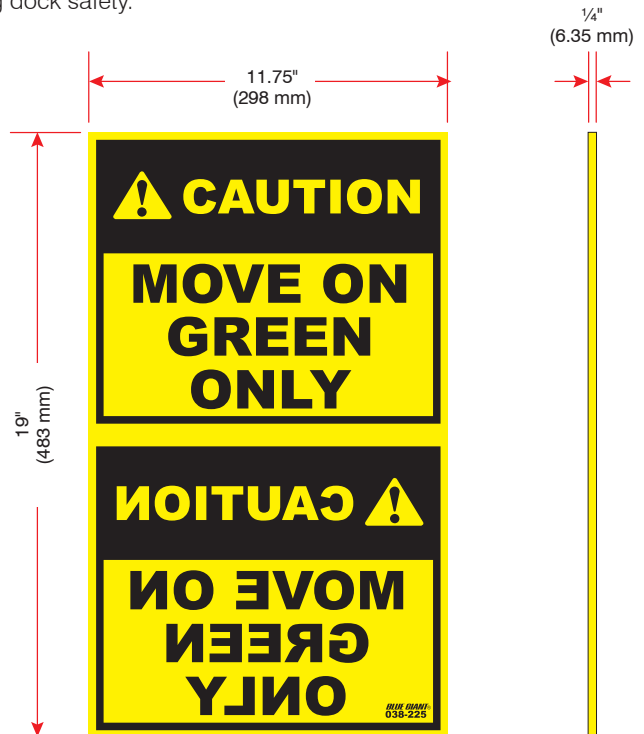

Exterior driver warning sign, part # 038-225.
(French 038-225F / Spanish 038-225S / Portuguese 038-225P)

BLUE GIANT[®]
BLUE GIANT EQUIPMENT CORPORATION

Corporate 410 Admiral Blvd
Mississauga, ON, Canada L5T 2N6
t 905.457.3900 f 905.457.2313

USA 6350 Burnt Poplar Road
Greensboro, NC 27409
www.bluegiant.com