

DANGER

1. Only trained and authorized personnel may operate this dock leveler.
2. Read, understand, and follow the instructions on this document.
3. Prior to using the dock leveler:
 - Ensure that the dock leveler is free and clear of all debris, snow, and ice.
 - Ensure that all personnel near the dock leveler are aware that it is being operated.
 - Operate the dock leveler through one complete cycle to confirm that it is functioning properly. If the dock leveler is equipped with a communications package, confirm that the lights are working as required.
 - Inspect unit for signs of structural damage or mechanical malfunction. If damage is observed or the restraint fails to operate properly, remove it from service and notify maintenance personnel immediately.
 - Confirm that the transport vehicle has been properly restrained.
4. When using the dock leveler:
 - Keep hands and feet clear of pinch points.
 - If the dock leveler is equipped with a light communication package, load and unload on green only.
 - Do not exceed the rated capacity as indicated on the serial plate.
 - Do not leave equipment or material unattended on the dock leveler.
 - Keep a safe distance from both edges.
 - If dock leveler fails to operate as outlined in the accompanying manual's operating instructions, refer to the **Troubleshooting** section.
5. If service or maintenance is required:
 - Only authorized service personnel shall maintain or service the unit.

APPLIES TO ALL DOCK LEVELERS



85 Heart Lake Road South
Brampton, Ontario, Canada L6W 3K2
Phone : 905-457-3900 Fax : 905-457-2313
www.BlueGiant.com

If calling within North America:
Phone: 1-800-669-7078
Fax: 1-888-378-5781

BLUE GIANT EQUIPMENT CORPORATION

OPERATING INSTRUCTIONS

Only for the Hydraulic Dock Leveler with Advanced Single Push Button Controls

The Blue Giant **Hydraulic Dock Leveler** is a high performance system. Heavy-duty beams welded at dynamic impact points guarantee sturdy deck support. It is designed to tilt up to 4" (102 mm) on either side, allowing full width contact between the lip and the truck bed and preventing damage to forks, tires, steering system, and load. Hydraulic lip cylinders increase operating efficiency and reduce maintenance requirements.

The **Single Push Button Control Station** controls an independent hydraulic dock leveler via a constant pressure button. The **Auto-Return** feature (optional) returns the dock leveler to the parked position should the truck depart suddenly from the loading dock. The **Overhead Door Interlock** (optional) prevents use of the dock leveler when the overhead door is in the down position, preventing damage to the door and the dock equipment.

DEPLOYING THE DOCK LEVELER

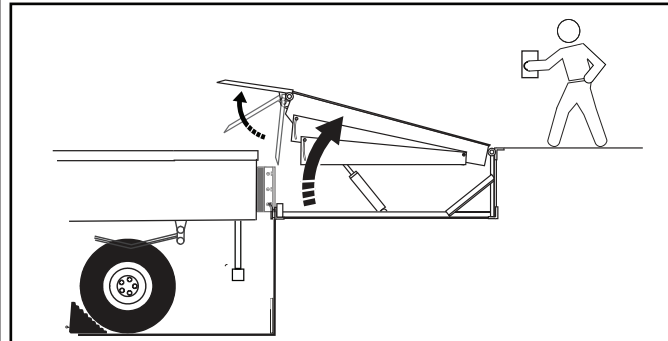

1. Raise the dock leveler by pushing the 'UP' button. If the button is still being pressed while the dock is in its fully raised position, the lip will then deploy

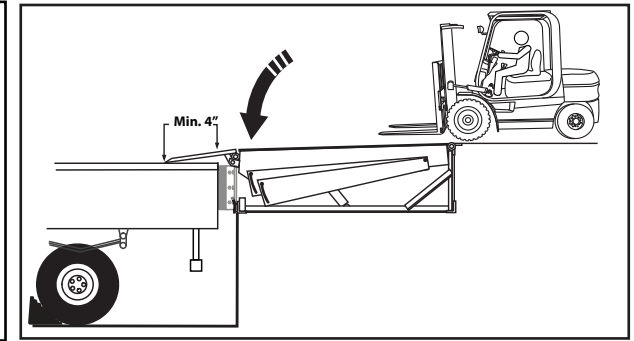

2. The dock leveler will then descend with the deployed lip on the vehicle load bed. When the dock has fully deployed on the load bed, loading and unloading may commence

STORING THE DOCK LEVELER

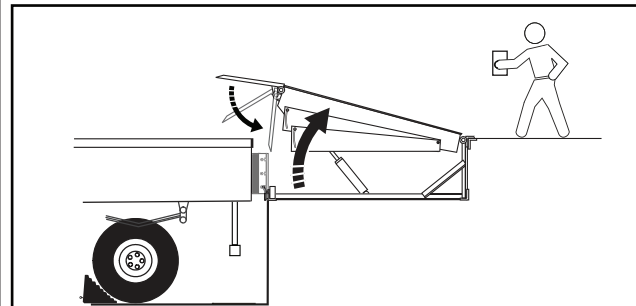

1. To store the dock leveler, press the 'UP' button. The dock will raise and the lip will retract. When the lip has fully retracted, release the button. The dock will resume the stored position, lip in lip keepers.

AUTO-RETURN FEATURE (OPTIONAL)

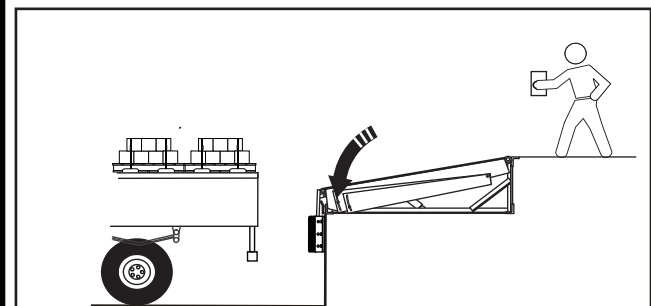

If the truck departs while the dock leveler is still resting on the load bed, the auto-return feature allows the dock leveler to automatically resume the stored position. This feature is turned on and off via a selector switch on the control box.