

OWNER'S MANUAL

STRONGARM™ HVR303 VEHICLE RESTRAINT WITH BLUE GENIUS™ TOUCH CONTROL



ACTUAL PRODUCT MAY NOT APPEAR EXACTLY AS SHOWN



WARNING

Do not operate or service this product unless you have read and fully understand the entire contents of this manual. Failure to do so may result in property damage, bodily injury or death.

BLUE GIANT®

TABLE OF CONTENTS

1.0 ABOUT THE STRONGARM™ HVR303 WITH BLUE GENIUS™ TOUCH CONTROL	3
1.1 OWNER'S PURCHASE RECORD	3
2.0 INTRODUCTION	4
2.1 WARRANTY INFORMATION	4
2.2 EXCLUSION OF LIABILITY	4
2.3 MANUFACTURER'S NOTE	4
2.4 OWNER'S RESPONSIBILITY	5
3.0 SAFETY MESSAGE COLOR IDENTIFICATION	6
3.1 OPERATIONAL SAFETY WARNINGS	6
4.0 LOCKOUT / TAGOUT PROCEDURE AND RULES	7
5.0 EMERGENCY VEHICLE RESTRAINT LOWERING PROCEDURE	7
6.0 CONTROL PANEL OPERATION	8
6.1 BUTTON FUNCTION	8
7.0 OPERATING INSTRUCTIONS	9
7.1 FUNCTIONAL DESCRIPTION	9
7.2 STOP BUTTON FUNCTION	10
7.3 PRIOR TO USE-EQUIPMENT IN STORED POSITION	10
7.4 TRAILER AT BAY	11
7.5 ENGAGING RESTRAINT	11
7.6 DEPLOYING THE DOCK LEVELER	12
7.7 RELEASING THE RESTRAINT ARM	12
8.0 ENGAGING THE OVERRIDE FEATURE	13
8.1 RELEASING THE OVERRIDE FEATURE	14
9.0 MAINTENANCE	15
9.1 PLANNED MAINTENANCE PROGRAM (PMP)	15
9.2 OPERATOR INSPECTION	15
9.3 ROUTINE SERVICING AND MAINTENANCE	15
9.4 PLANNED MAINTENANCE PROGRAM INTERVALS	15
9.5 MAINTENANCE SEQUENCE	15
9.6 PMP CHECKLIST - STRONGARM™ HVR303 VEHICLE RESTRAINT	16
10.0 RECOMMENDED SPARE PARTS	17
10.1 STANDARD OPERATIONAL COMPONENTS	17
10.2 OPTIONAL SUPPORT COMPONENTS	18
11.0 DECAL IDENTIFICATION AND LOCATION	19
12.0 EQUIPMENT COMPONENT ILLUSTRATIONS	20
12.1 COMPONENTS AS SHIPPED CHECKLIST	20
12.2 MECHANICAL ASSEMBLY - 56-010200 / 56-010200-ZP	21
12.3 GENERAL DIMENSIONS	22
12.4 GEARMOTOR ASSEMBLY - 1005462	23
12.5 CONTROLS	24
12.6 JUNCTION BOX W/REMOTE I/O	25
12.7 JUNCTION BOX ASSEMBLY	25
12.8 DOCK INTERLOCK SENSOR	26
12.9 EXTERIOR TRAFFIC LIGHT / MIRROR IMAGE SIGN	26
13.0 VEHICLE RESTRAINT TROUBLESHOOTING	27
14.0 BLUE GENIUS™ LCD MESSAGES	28
15.0 WIRING DIAGRAM	28
15.1 WIRING DIAGRAM—115V SINGLE PHASE	29

1.0 ABOUT THE STRONGARM™ HVR303 WITH BLUE GENIUS™ TOUCH CONTROL

With a restraining force of 32,000 lb (14,500 kg), the StrongArm™ HVR303 electric lock vehicle restraint counteracts the dangers associated with unexpected horizontal or vertical trailer movement. Its vertical restraining range of 9" to 25" (227 – 635 mm) and instant compensation float of 16" (406 mm) enable it to match active trailer movement, making the HVR303 work well with air-ride suspension systems and minimizing the risk of accidental separation and worker injury.

The Blue Genius™ Gold Series II Touch Control Panel's features include an LCD menu screen, function (ENGAGE, RELEASE, STOP) buttons and a flat-surface keypad with unique touch sensors.

An interior and exterior lights communication system keeps truck drivers and warehouse personnel advised of safety conditions during dock operations.

1.1 OWNER'S PURCHASE RECORD

OWNER'S PURCHASE RECORD
Please record information for future inquiries and to validate warranty. (See Section 2.1 for warranty validation)

Dealer:	Date in Service:
	Number of Units:
Serial Number:	Door #:
Serial Number:	Door #:
Serial Number:	Door #:
Serial Number:	Door #:
Serial Number:	Door #:
Serial Number:	Door #:
Serial Number:	Door #:
Serial Number:	Door #:
Serial Number:	Door #:

The manufacturer offers a full line of dock levelers, dock safety equipment, accessories, ergonomic and scissor lift equipment, and industrial trucks. Concurrent with a continuing product improvement program, specifications are subject to change without notice. Please contact the manufacturer for latest information. Some features illustrated may be optional in certain market areas.

NOTICE

See section 11.0 "Decal Identification and Location," item #7 for serial number location.

2.0 INTRODUCTION

The following is a quick reference to important procedures that must be followed while using the Vehicle Restraint System. It is not intended to cover, or suggest that it does cover, all procedures necessary to ensure safe operation. All operators should be aware of and abide by all workplace safety regulations applicable to the operation of the Vehicle Restraint System. These laws and regulations include but are not limited to:

- The Occupational Safety and Health Act
- Canada Occupational Health and Safety Regulations
- Occupational Safety and Health Acts for Individual States (USA)

For additional information on these regulations as well as industry standards that may apply to this product, please contact:



American National Standards Institute (ANSI)
 1430 Broadway
 New York, NY 10018
 Telephone: 212.642.4900
www.ansi.org

Also a member of:



Loading Dock Equipment Manufacturers
 A Product Section of Material Handling Industry of America
 A Division of Material Handling Industry
 8720 Red Oak Blvd, Suite 201
 Charlotte, NC, 28217-3992
 Telephone: 704.676.1190
www.mhi.org/lodem

2.1 WARRANTY INFORMATION

Thank you for purchasing Blue Giant products. We appreciate your business, and are confident that our product will serve you for many years to come. In the event that you experience a problem with our product, our Warranty Center is here to support the Blue Giant Product(s) that you have purchased.

To validate warranty on recently purchased equipment, please complete and submit your information with our on-line Warranty Registration at www.BlueGiant.com.

For more information about Blue Giant Warranty Support, please contact your local Blue Giant Equipment dealer, representative or authorized partner near you. You may also visit www.bluegiant.com or phone 1.905.457.3900.

DEALER INFORMATION

Name:

Contact:

Telephone:

* **NOTE:** All products must be registered to qualify for warranty.

2.2 EXCLUSION OF LIABILITY

The manufacturer assumes no liability for damage or injury to persons or property which occur as a result of defects or faults in or incorrect use of the Vehicle Restraint System. The manufacturer also assumes no liability for lost profits, operating downtimes, or similar indirect losses incurred by the purchaser. Injury to third parties, irrespective of its nature, is not subject to compensation.

The manufacturer reserves the right to make changes at any time to the modules, components, and accessories, concurrent with its continuing product improvements and development program. Specifications, operating instructions, and illustrations included in this manual are subject to change without notice. Please contact manufacturer for the latest information.

2.3 MANUFACTURER'S NOTE



The Vehicle Restraint has been carefully inspected and tested at the manufacturer's plant prior to shipment, but should be checked upon receipt for transport damage. Any observed transport damage is to be listed on the signed copy of the freight document. Notify the freight forwarder of any damage WITHIN 48 HOURS.

2.4 OWNER'S RESPONSIBILITY



1. The owner should recognize the inherent danger of the interface between the dock and the freight carrier. The owner should, therefore, train and instruct operators in the safe use of the dock equipment and accessories in accordance with the manufacturer's recommendations.
 2. The owner should thoroughly familiarize themselves with the following procedures and specifications, and request immediate replacement of all manufacturer-supplied documents that are missing, damaged, or otherwise illegible.
 - Installation instructions
 - Operating instructions
 - Planned maintenance procedures
 - Inspections procedures
 - Replacement parts lists
- Upon receipt of any newly purchased dock equipment, the owner shall verify the presence of owner's manuals, operating placards, and any other documentation necessary for training dock personnel how to use the equipment safely and effectively.
3. Manufacturer's recommended periodic maintenance and inspection procedures shall be followed, and written records of the performance of these procedures should be kept as per warranty guidelines.
 4. Dock equipment that is structurally damaged, experiencing performance irregularities, or has been potentially compromised (i.e. sudden loss of support due to premature truck departure) shall be removed from service until a trained and authorized manufacturer's representative can conduct an inspection and perform any necessary repairs.
 5. As with any piece of machinery, dock equipment requires routine maintenance, lubrication, and adjustments. Your local Blue Giant® representative offers owners the option of a Planned Maintenance Program (P.M.P). As part of this service, your local Blue Giant representative will do all routine maintenance, lubrication, and adjustments.
 6. The owner shall ensure that all nameplates, caution/instruction markings or labels are in place and legible, and that the appropriate operating/maintenance manuals are provided to authorized users. Replacement name plates, caution/instruction labels, and manuals containing operating and maintenance instructions are available through the Blue Giant Aftermarket Solutions Department. See Section 11.0 "*Decal Identification and Location*" for more information.
 7. Modifications or alterations of dock equipment shall be made only with written permission of the original manufacturer. These changes shall also satisfy all safety recommendations of the original equipment manufacturer for the particular application of the dock equipment.
 8. The owner or a trained and authorized representative shall verify that all freight carrier brakes have been applied and a vehicle restraint and/or wheel chocks properly engaged before cross-docking procedures such as loading and unloading begin.
 9. Unless specifically agreed to in writing by Blue Giant Equipment Corporation at the time of order (and prior to manufacture), all Blue Giant Dock equipment is sold as a complete offering, and must not be altered or added to in any manner (which includes configuration and function) without written permission from an authorized manufacturer's representative.
 10. If, at the request of the owner, Blue Giant does not supply all or some of the dock equipment power unit and/or control panel components, the owner shall assume responsibility for any and all operational and safety issues associated with the resulting configuration.

3.0 SAFETY MESSAGE COLOR IDENTIFICATION

This manual includes color-coded safety messages that clarify instructions and specify areas where potential hazard exists. To prevent the possibility of equipment damage and serious injury or death, please observe strictly the instructions and warnings contained in the messages. If warning decals become damaged or missing, replace them immediately. Avoid accidents by recognizing dangerous procedures or situations before they occur.

 DANGER	NOTICE
Serious injury or death will likely occur if the instructions are not followed.	Procedures marked important must be followed in order to prevent damage to machinery.
 WARNING	 CAUTION
Serious injury or death may occur if the instructions are not followed.	Instructions marked caution concern safe operating procedure. Failure to comply may result in personal injury.

3.1 OPERATIONAL SAFETY WARNINGS

 DANGER	
<p>Keep hands and feet away from operating space of the restraint apparatus.</p> <p>CRUSH HAZARD</p>  	<ol style="list-style-type: none"> 1. Do not operate the dock equipment while anyone is standing in its path. 2. Lift the dock equipment with suitable hoisting equipment only. Do not stand under the dock equipment or any heavy object while it is being hoisted. 3. BEFORE BEGINNING ANY SERVICE PROCEDURES: Disconnect the power and follow all lockout / tagout procedures outlined in this manual.

 WARNING
<ol style="list-style-type: none"> 1. Installation must be performed only by trained and authorized personnel. 2. Prior to installation, place adequate barriers to prevent vehicle traffic from entering the work area. 3. During installation, anchors must be properly torqued to achieve the necessary anchoring strength. DO NOT USE IMPACT DRIVERS. 4. Any electrical work must be performed by qualified personnel only. 5. Do not remove the wheel chocks until loading /unloading is finished and the truck is cleared for departure or the vehicle restraint has been released and the lights have changed to RED inside and GREEN outside.

NOTICE
<ol style="list-style-type: none"> 1. Do not ground welding equipment to any electrical components. 2. Do not allow the drill to go too deeply into the control box, as damage may occur to the control systems. 3. Never use air to blow debris from the control box. Use a vacuum to perform any necessary cleaning. 4. Do not connect green ground lead into control box or junction box until all welding has been completed. 5. If an extension plate / box is required, securely mount it on the restraint with hardware provided before shimming and drilling. 6. Improper adjustments and / or lubrication may cause operational problems with equipment.

 CAUTION
<ol style="list-style-type: none"> 1. Only trained personnel should operate or service this equipment. 2. Do not operate the dock equipment until the transport vehicle is parked against the dock bumpers. 3. Always park the dock equipment after use. 4. Conduct routine inspections and maintenance. Failure to do so could cause equipment damage and or personal injury. 5. Always call your authorized service representative or manufacturer immediately if a malfunction occurs.

4.0 LOCKOUT / TAGOUT PROCEDURE AND RULES

In accordance with the rules and regulations of the Occupational Safety and Health Administration (OSHA), all affected employees must be notified that the machine or equipment will be shut down and locked out to perform repair or maintenance work. The work area must be checked to ensure that all personnel have been removed or safely repositioned. The machine or equipment power supply shall be locked in the OFF position or disconnected from the energy source. Blue Giant strongly recommends that only OSHA-approved lockout devices and procedures be utilized.

The energy isolating device must bear a prominent warning tag indicating that work is being done on the equipment and the name of the authorized employee responsible for the lockout. It is mandatory that tagout notices not be susceptible to deterioration or illegibility due to weather conditions or exposure to chemicals and moisture.

! **WARNING**

Always lockout and tagout any power source before performing any work on any electrical devices or electrical controls according to OSHA regulations and approved local electrical codes.

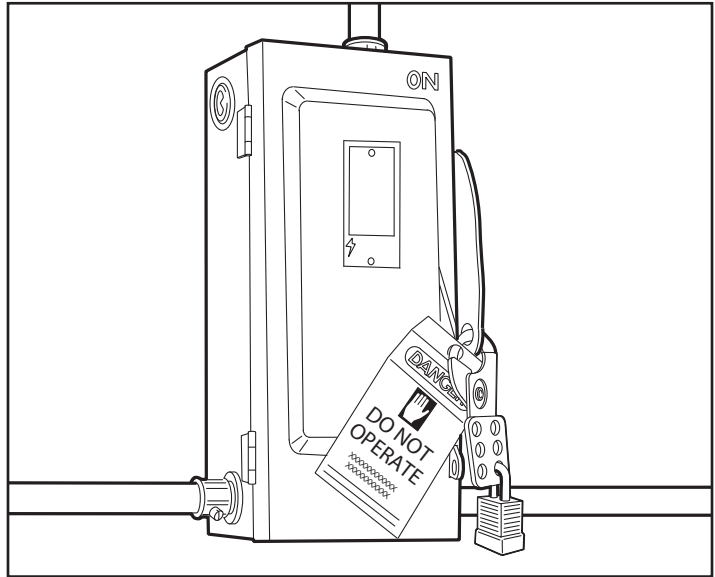

Approved way to lockout / tagout.

5.0 EMERGENCY VEHICLE RESTRAINT LOWERING PROCEDURE

In the event of a power/malfunction failure to the control panel while the restraint arm is in the vertical locked position, the locking mechanism can be released manually. The restraint hook can then be lowered to the stored position. In case of restraint or control panel malfunction, see below.

NOTE: Turn-off power switch / disconnect before performing manual emergency procedure.

NOTE: Confirm that the trailer ICC bar is not applying pressure to the hook / lock mechanism before attempting to unlock. Otherwise, manual release will not be possible.

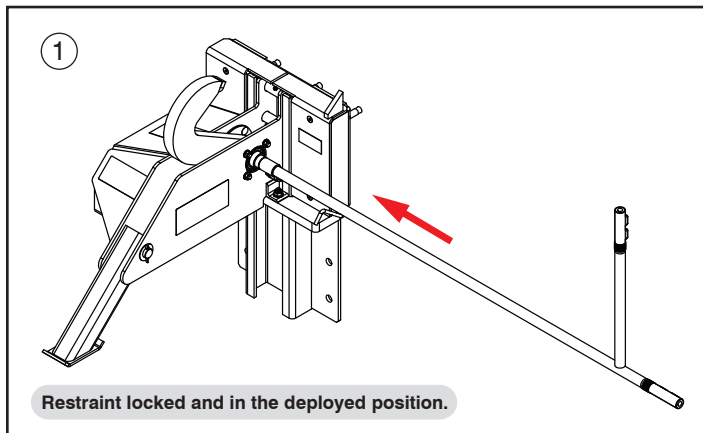

Insert unlocking bar (Part# 56-011930) into slot with pressure for leverage.

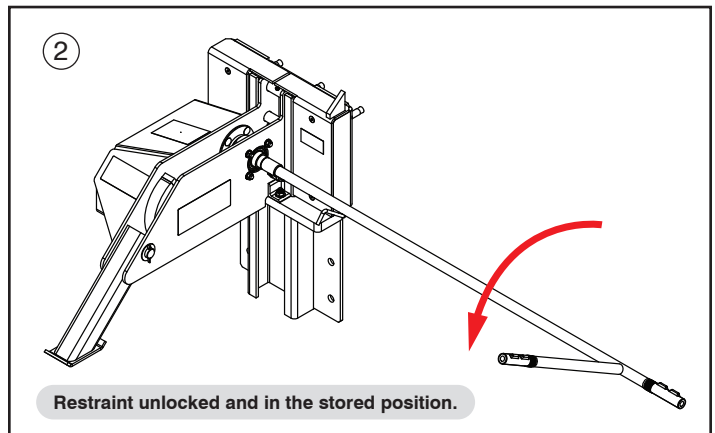

Rotate bar away from the wall to unlock. Restraint hook can descend to the stored position.

6.0 CONTROL PANEL OPERATION

Controls combinations of all supported dock equipment: one individual vehicle restraint, one individual dock leveler, and controls for a door. Also equipped with touch buttons, inside forklift operator traffic lights, operator menu screen, and keypad for coded features.

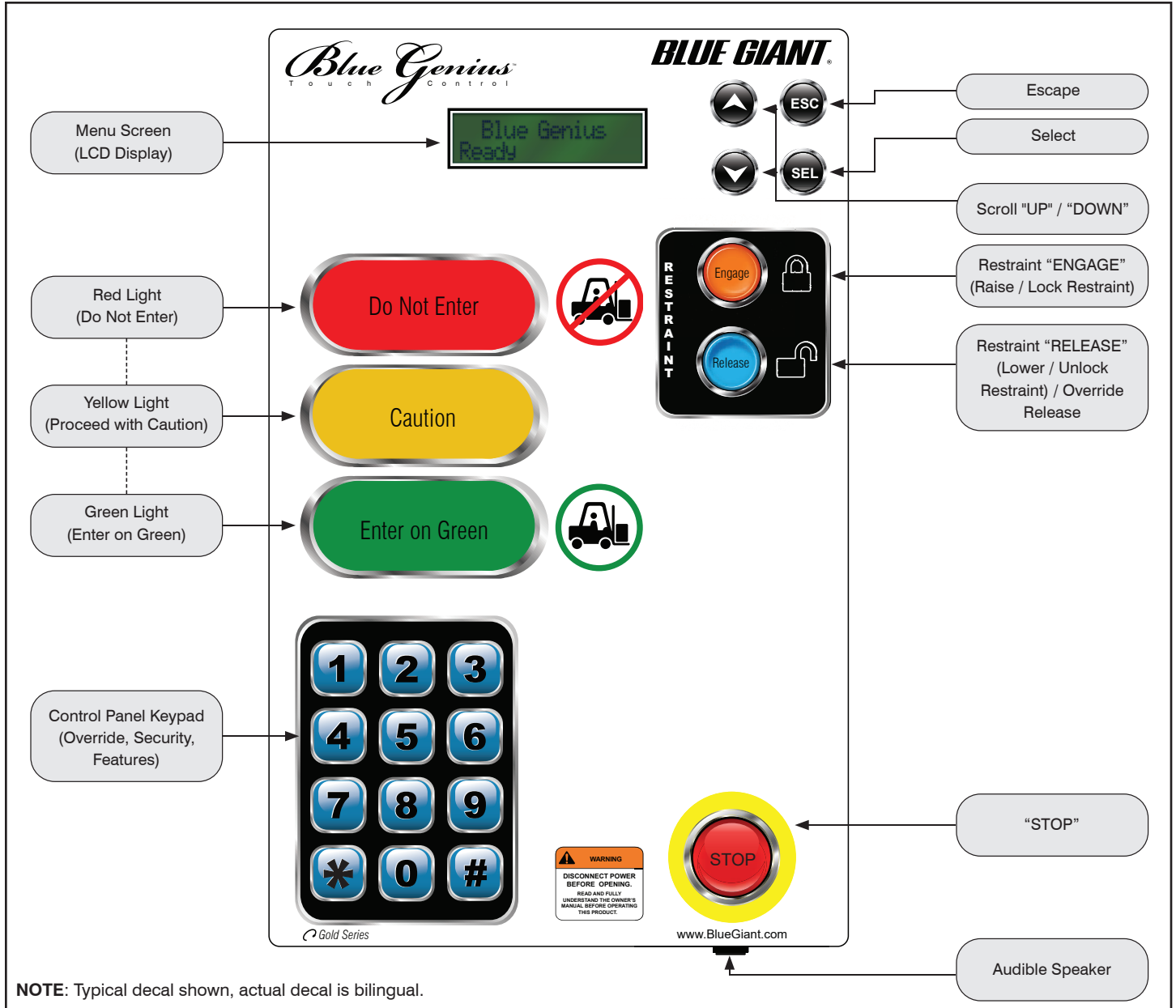

6.1 BUTTON FUNCTION

When touching any of the function buttons or keypad, use the pad of the finger. The control panel's unique touch sensors detect the proximity of the dock operator's finger. Audible touch buttons and keypad on the control panel provide instant sound feedback to user input.

The 'Engage' and 'Release' buttons require only a single touch to activate their respective functions. Do not apply constant pressure

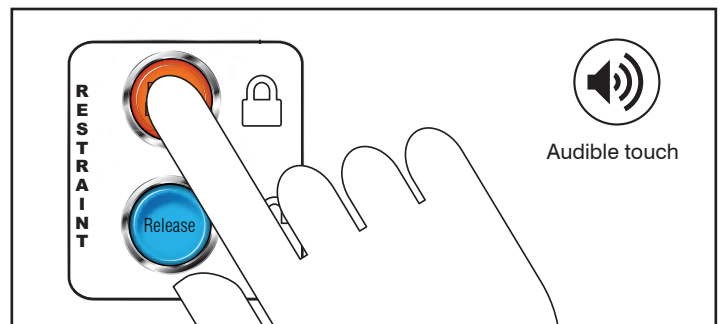

7.0 OPERATING INSTRUCTIONS

WARNING

Do not operate this vehicle restraint unless you have been trained and authorized to do so, and have read and understood all of the safety information and instructions contained in this manual.

Do not operate this restraint until you have checked its condition. Report the need for repairs to your supervisor immediately and do not operate the unit until repairs are made.

Never try to lift or move any part of the vehicle restraint manually. Keep hands and feet clear of vehicle restraint pinch points.

It is the responsibility of the owner / operator of truck / vehicle to (whenever possible) exhaust the air from air-ride suspension systems prior to performing loading or unloading. Because ICC bars differ in strength and construction, review the need to use wheel chocks in conjunction with the vehicle restraint.

This vehicle restraint is designed for rear impact guards (RIG) and rear impact protection (ICC Bar) that follow the Federal Motor Carrier Safety Administration guidelines (FMCSA section 571.223 and 571.224) + NHTSA (National Highway Traffic Safety Administration) guidelines.

OPERATING INSTRUCTIONS

Only for the StrongArm™ HVR303 Vehicle Restraint

A

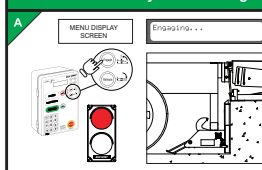

ENGAGE RESTRAINT

1. Open the overhead door and visually confirm that the vehicle has an ICC bar and that it is aligned and in range of the restraint arm. The control panel light is RED and the traffic light is GREEN.
2. Touch the 'Engage' button. The arm will rotate from the home position to secure the ICC bar and the LCD screen will read "Restraint Engaging." The traffic light will turn RED and the control panel light will remain RED. When the ICC bar is secured, the LCD screen will read "Restraint is Engaged," followed by "Dock Leveler Restored" and "Ready to Raise Dock." After the dock is deployed onto the truck bed, the control panel light will turn GREEN.

B

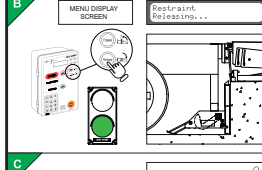

DISENGAGE RESTRAINT

1. After the dock leveler is safely parked, touch the 'Release' button to disengage the vehicle restraint. The control panel light will change to RED and the LCD screen will read "Restraint Releasing." When the arm reaches the home position, the LCD screen will read "Blue Genius Ready" and the traffic light will turn GREEN.

NOTE: If the restraint arm was not properly parked, the LCD screen will read "Arm Blocked." Consult the Troubleshooting section of the manual.

C

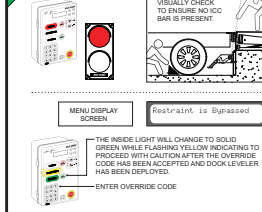

VEHICLE RESTRAINT OVERRIDE

1. Touch the 'Engage' button. If a vehicle's ICC bar is absent or cannot be engaged, the LCD screen will read "ICC Bar Not in Range." A visual inspection is now necessary to determine whether the vehicle needs to be realigned or if wheel chocks are necessary. The control panel light and traffic light are both RED.
2. Press the "key" on the keypad. The LCD screen will read "Enter Code _____." Enter the factory set default supervisor code **NOTE:** this code can be changed. Please call your Blue Giant distributor for further information) the LCD screen will read "Dock Leveler Restored" and then "Ready to Deploy Dock," followed by "Restraint is Bypassed." Once the dock is deployed and home sensor becomes inactive, the control panel light will turn GREEN while flashing YELLOW.
3. When work has been completed, store the dock leveler. Then touch the 'Release' button on the control panel. The control panel light will turn RED, warning dock staff that the vehicle is no longer accessible. The outside traffic light will turn GREEN, advising the truck driver that it is safe to depart once the wheel chocks are removed.

D

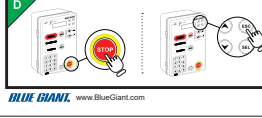

STOP PROCEDURE

1. Touching the 'STOP' button during operation will cut power to the restraint. If the arm is in mid-travel, it will lower to a hard stop via gravity. To exit the 'STOP' mode touch 'ESC'.

BLUE GIANT, www.BlueGiant.com 038-847E

HVR303 operation placard—part # 038-847E.

7.1 FUNCTIONAL DESCRIPTION

The vehicle restraint is used to restrain a trailer at the loading dock. When engaged, it secures a vehicle's under ICC bar, restricting any forward movement caused by vehicle creep or unscheduled departure. It is electrically operated via the Blue Genius™ Touch Control Panel, and comes standard with an automatic lights communication package consisting of red/yellow/green control panel lights and exterior red/green LED traffic lights.

OUTSIDE TRAFFIC LIGHT

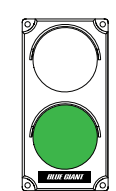

Exterior red / green traffic lights advise the truck driver when it is safe to depart.

INSIDE COMMUNICATION LIGHTS & CONTROL PANEL

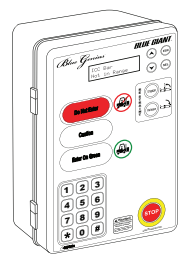

Red / yellow / green control panel lights keep forklift operators and warehouse personnel advised of safety conditions at the loading dock.

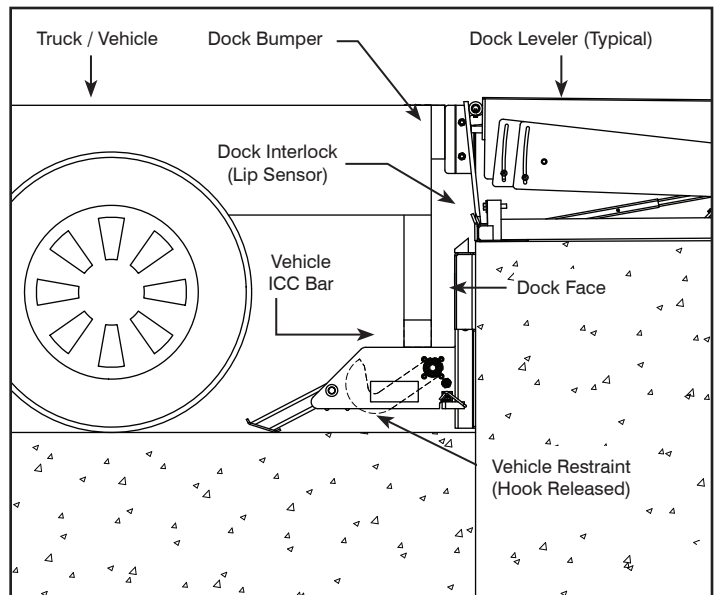

ADVANCED SAFETY FEATURES

7.2 STOP BUTTON FUNCTION

Should an unexpected interference occur or potentially dangerous situation arise, the Blue Genius™ control panel has a temporary 'STOP' button. Touching the 'STOP' button during operation will cause the unit to stop in mid motion and the internal alarm will beep until the stop function is exited. The control panel light will flash RED and the exterior traffic light will be RED. To exit the 'STOP' mode touch the 'ESC' button.

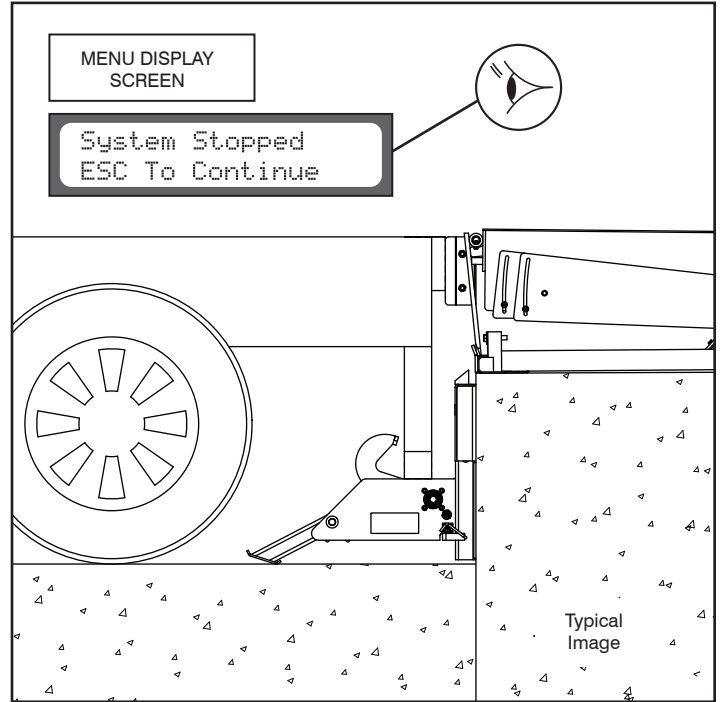
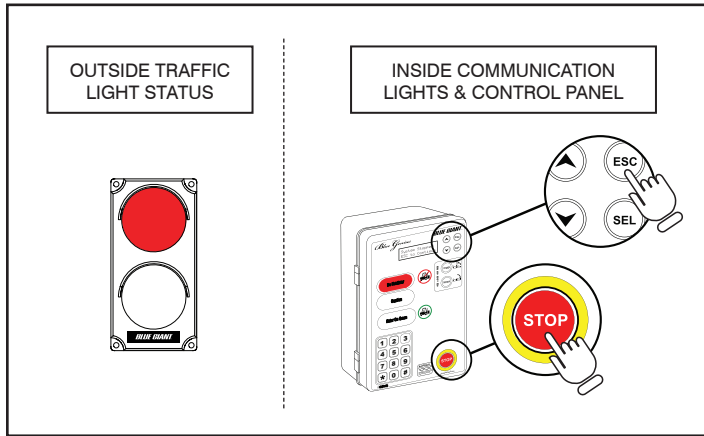

STANDARD OPERATION PROCEDURES

7.3 PRIOR TO USE: EQUIPMENT IN STORED POSITION

The Blue Genius™ control panel is powered on and ready for use. The restraint apparatus is in the home position and the dock leveler lip is parked safely in the lip keepers. The outside traffic light is GREEN and the control panel light is RED.

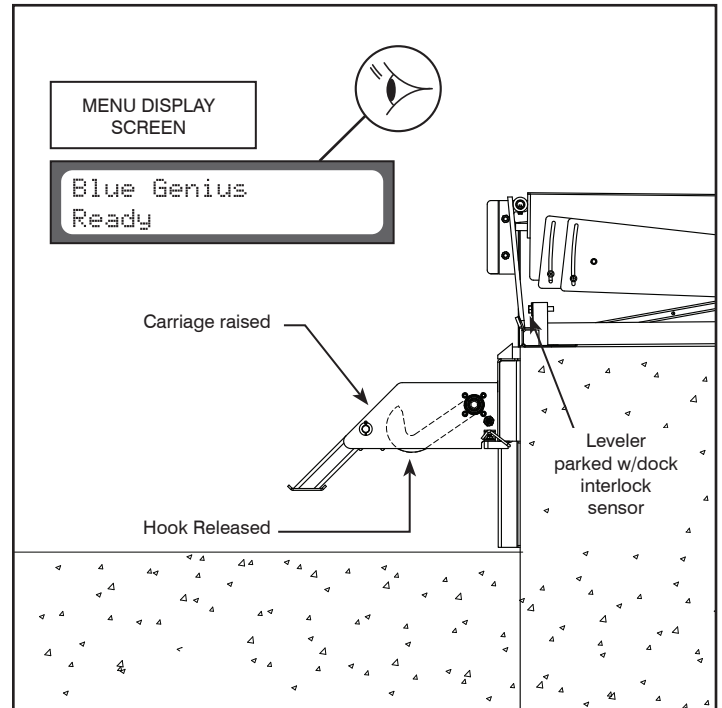
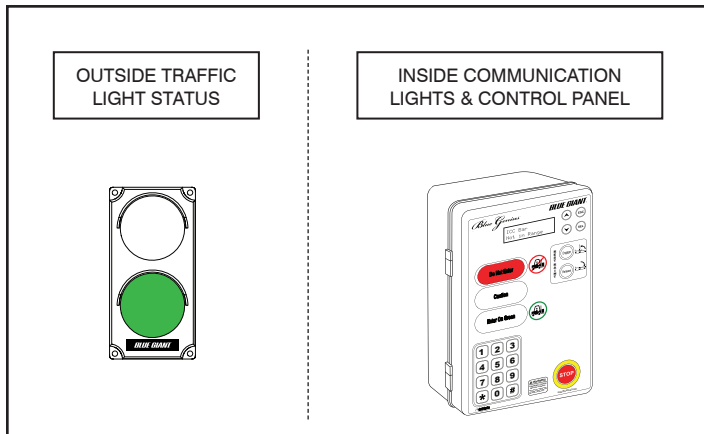

7.4 TRAILER AT BAY

The truck reverses into position against the dock leveler bumpers. The outside traffic lights are GREEN and the control panel light is RED.

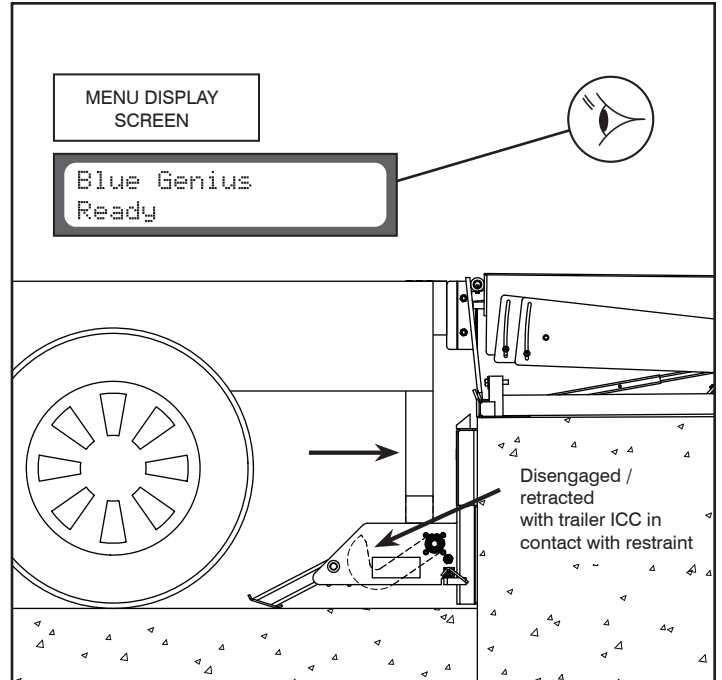
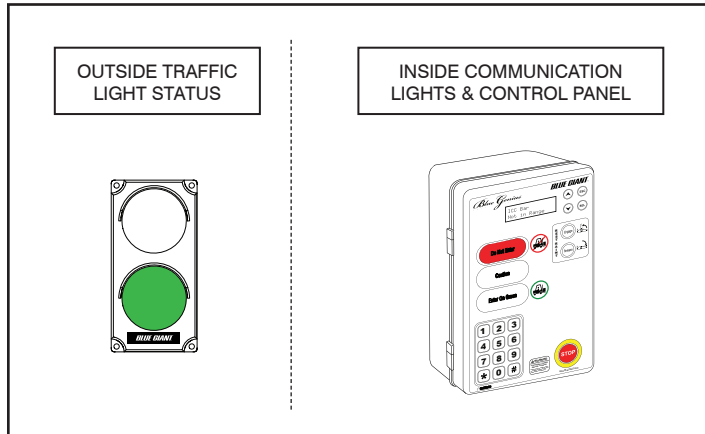

7.5 ENGAGING RESTRAINT

Touch the 'Engage' button on the control panel. The securing apparatus will exit the stored position to secure the truck's ICC bar. The LCD screen will read 'Engaging'. The traffic light will turn RED and the control panel light will remain RED. When the ICC bar is secured, the LCD screen will read 'Restraint is Engaged', followed by 'Dock Leveler Restored' and 'Ready to Raise Deck'.

NOTE: For vehicles without an ICC bar, or if the restraint apparatus cannot successfully engage, please refer to the 'Vehicle Restraint Override Feature' instructions in this section of the manual.

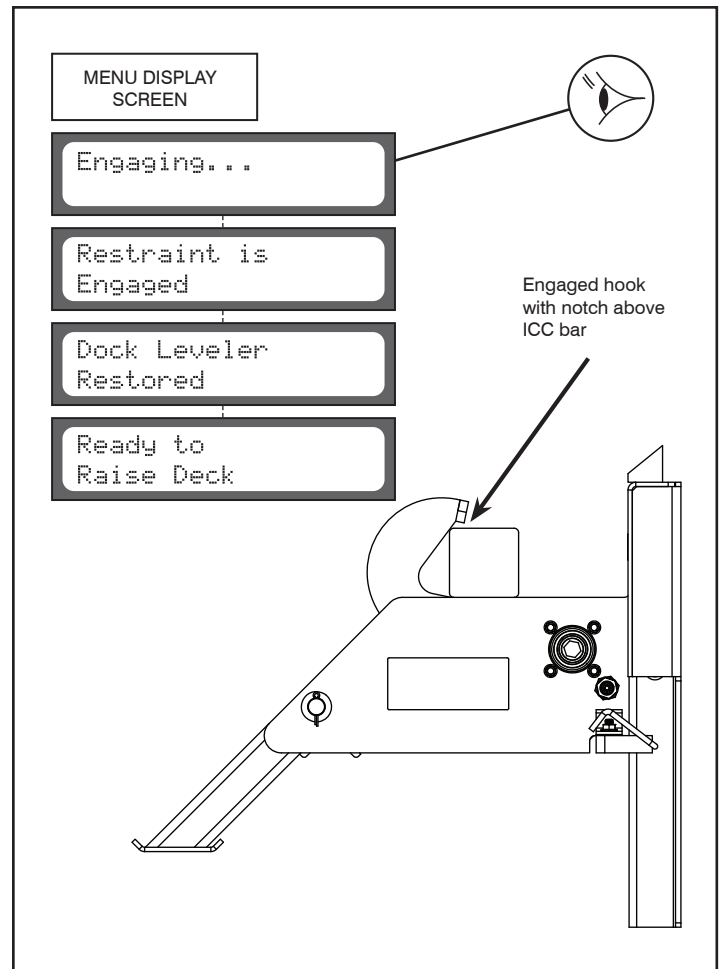
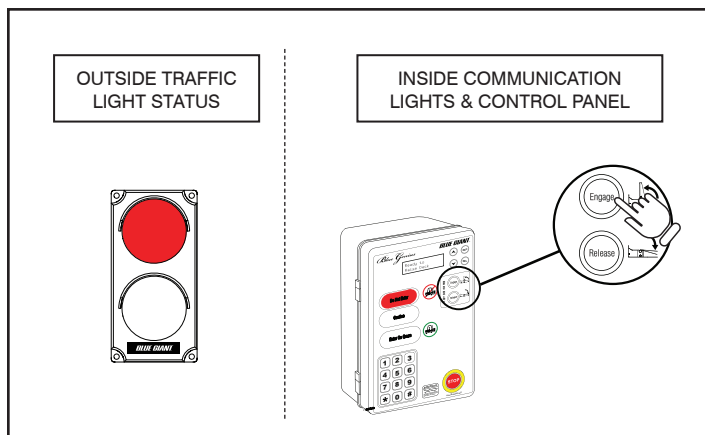

7.6 DEPLOYING THE DOCK LEVELER

Deploy the dock leveler (supplied by others) using controls provided by original manufacturer. When the deck rises, the LCD screen will read 'Deck Deployed'. When the dock leveler deploys onto the trailer bed, the outside traffic light will be RED, warning the truck driver to stay in place. The control panel light will be GREEN, advising dock staff that loading and unloading may safely begin.

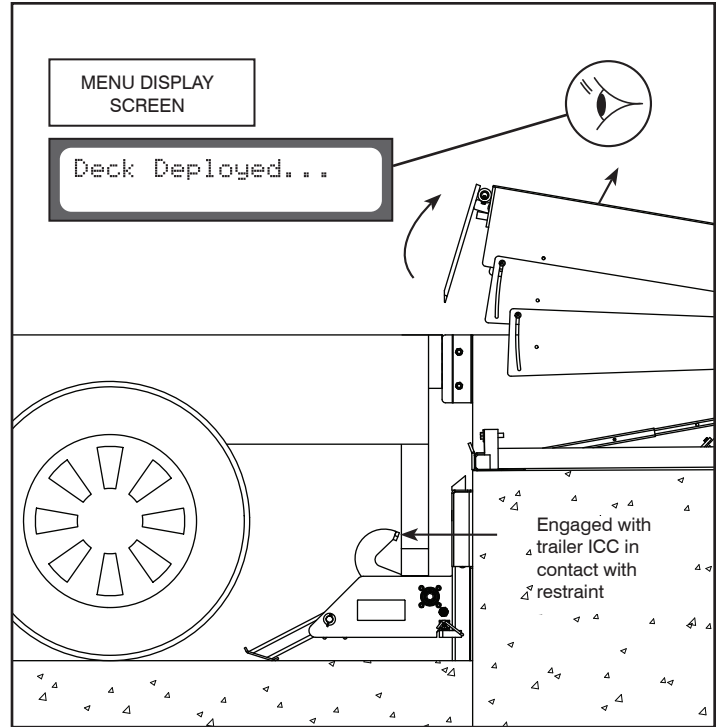
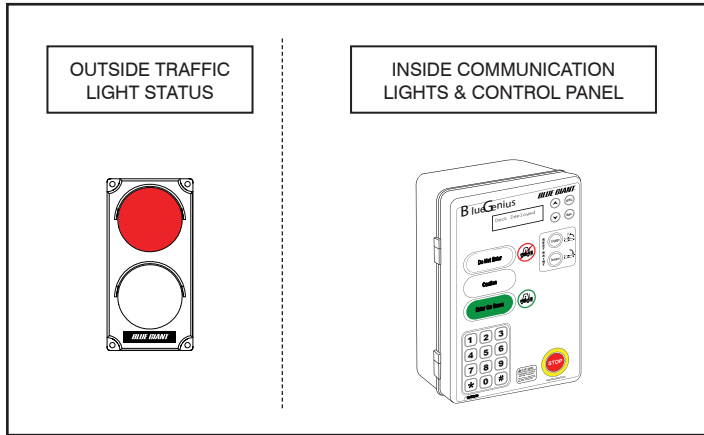

PERFORM LOADING AND UNLOADING

7.7 RELEASING THE RESTRAINT ARM

After the dock leveler is safely parked, the control station light will turn RED while the outside traffic light remains RED. Touch the 'Release' button to disengage the vehicle restraint. The LCD screen will read 'Restraint Releasing.' When the restraint hook reaches the home position, the LCD screen will read 'Blue Genius Ready' and the outside traffic light will turn GREEN.

NOTE: If the securing apparatus was not properly parked, the LCD screen will read 'Arm Blocked'. Consult the Troubleshooting section of the manual.

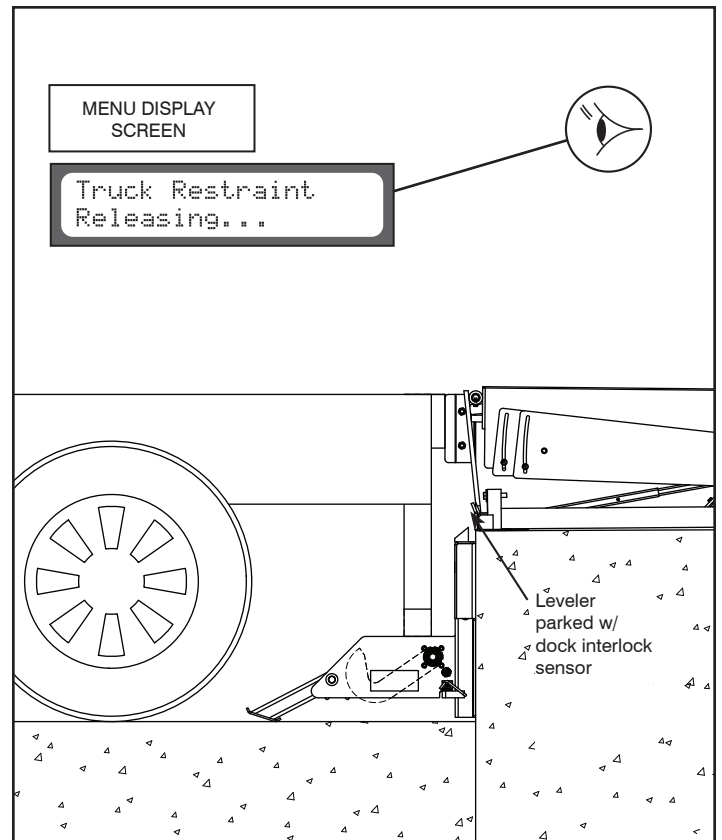
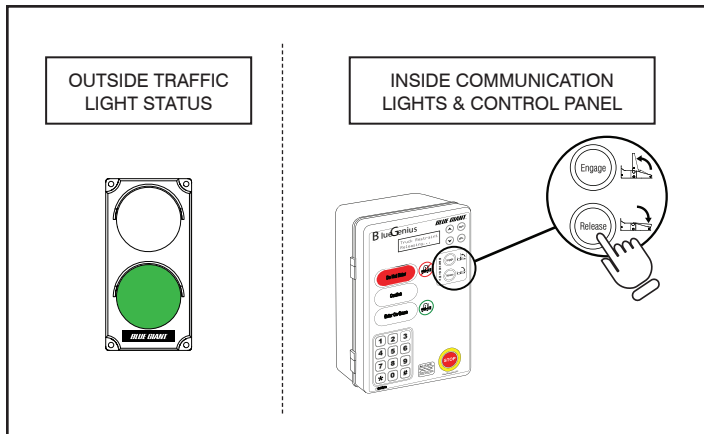

8.0 ENGAGING THE OVERRIDE FEATURE

Should it be necessary to bypass the vehicle restraint function (i.e. the truck has an outdated, damaged, or missing ICC bar), a system-approved override code may be entered via the Blue Genius™ touch keypad. This code can be used whether or not the dock leveler is interlocked with the Blue Genius.™ Ensure that the vehicle is manually chocked before loading and unloading begins.

NOTE: If a visual inspection confirms that the ICC bar is missing or too damaged to be secured then depending on your Blue Genius Software version:

- Up to Version 3.0 (inclusive), bypass Step 1 in the instructions below and go directly to Step 2, which explains how to enter the Override Code.
- From Version 3.1 and higher, step 1 is required sequence and then proceed to step 2, follow the instructions. Alternative sequence processes may be available, please consult your Blue Giant representative.

1. During "Engaging Restraint" (Section 7.5), the LCD screen may read "ICC Bar Not In Range." This message indicates that a vehicle's ICC bar is absent or cannot be engaged.

Determine whether the vehicle needs to be realigned or if wheel chocks are necessary.

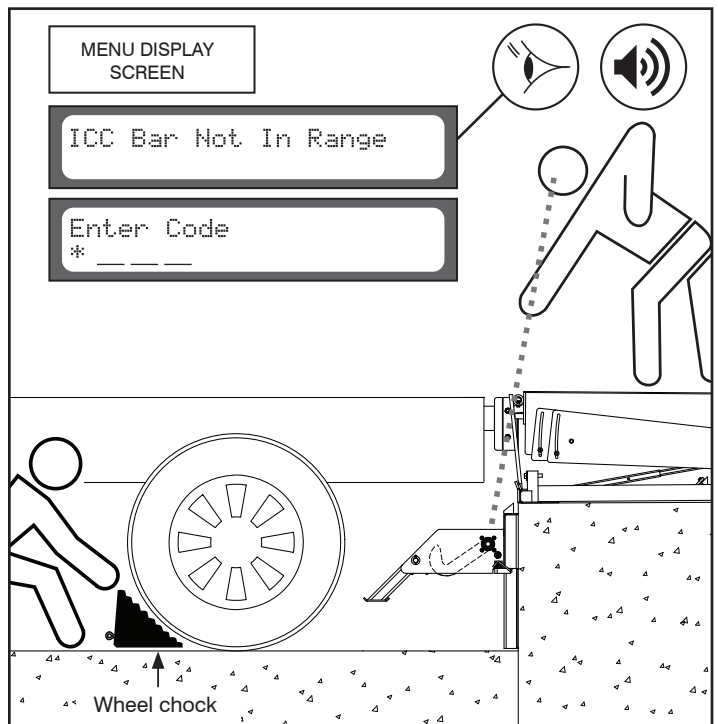

- 2A. Press the * key on the keypad. The LCD screen will read 'Enter Code * _ _ _'.

Enter the supervisor code (default factory set code is '247').

NOTE: The default code can be changed. Please call your Blue Giant representative for further information.

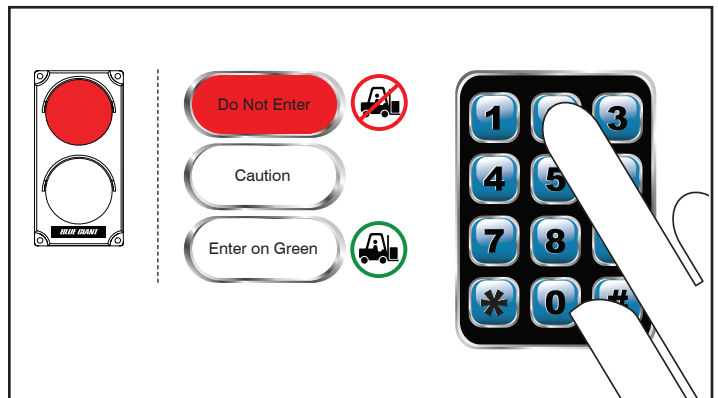

8.0 ENGAGING THE OVERRIDE FEATURE CONT'D.

Continue operation of overhead door, dock leveler, and vehicle restraint as outlined in Section 7.5 "Engaging Restraint". The following indicators will appear:

- 2B. The LCD screen will read 'Dock Leveler Restored' and then "Ready to Deploy Deck," followed by "Restraint is Bypassed."

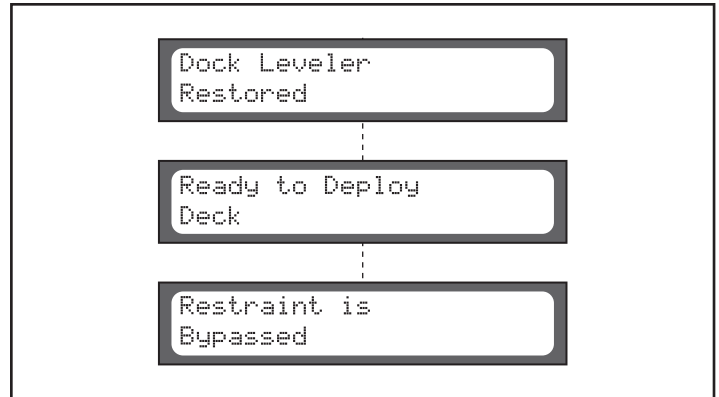

- 2C. Once the deck is deployed and the home/lip sensor becomes inactive, the control panel light will turn GREEN while flashing YELLOW. This indicates that the vehicle restraint is not engaged.

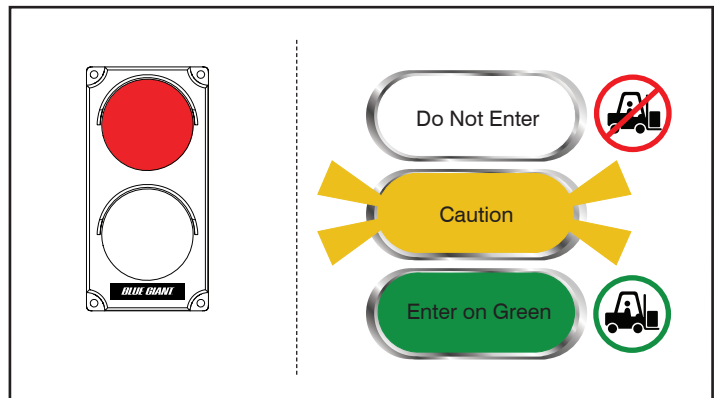

8.1 RELEASING THE OVERRIDE FEATURE

1. Store the dock leveler. (**NOTE:** Override is still active when dock leveler and vehicle restraint are in the parked position). The control panel light will turn RED.

Touch the 'Release' button on the control panel to release the override. The control panel will verify that the vehicle restraint has been lowered to the home position. The LCD screen will read "Blue Genius Ready."

The exterior traffic light will turn GREEN, advising the truck driver that it is safe to depart once the wheel chocks are removed.

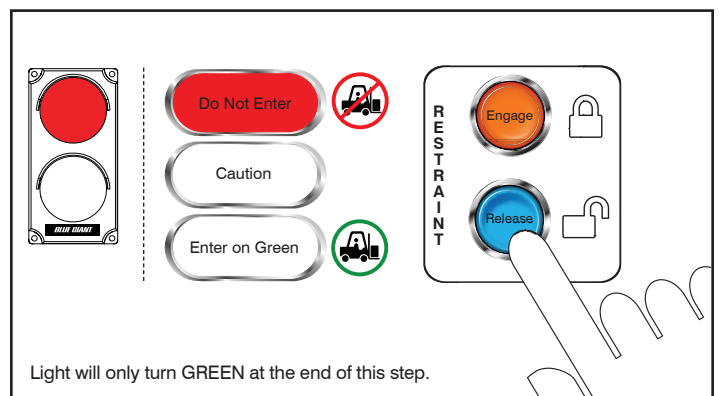

9.0 MAINTENANCE



WARNING

Do not operate and/or service this vehicle restraint until you have read and understood all of the safety information and instructions contained herein and on the vehicle restraint.

Do not work under or around the vehicle restraint without first placing adequate barriers to positively prevent vehicle traffic from entering the work area.

Follow proper lock-out/tag-out procedures.

Keep hands and feet clear of vehicle restraint pinch points and wear appropriate safety attire – glasses, gloves and work boots.

9.1 PLANNED MAINTENANCE PROGRAM (PMP)

In addition to the daily operator inspection, the manufacturer recommends (and local government regulations may require) that a planned maintenance program (PMP) and safety inspection program be performed by a trained and authorized service technician on a regular basis to maintain the equipment in safe operating condition. The PMP will provide an opportunity to make a thorough inspection of the safety and operating condition of the dock leveler. Necessary adjustments and repairs can be done during the PMP, which will increase the life of components and reduce unscheduled downtime.

Recommended procedures for a periodic planned maintenance program that covers inspections, operational checks, cleaning, lubrication, and minor adjustments are outlined in this manual.

An authorized dealer or distributor is prepared to assist with a planned maintenance program by offering trained service personnel with expertise in dock leveler maintenance requirements.

9.2 OPERATOR DAILY INSPECTION

The vehicle restraint should always be examined by the operator PRIOR TO ANY USE to verify that it is safe to operate.

The manufacturer recommends making multiple photocopies of the PMP Checklist (See Section 9.6 “*PMP Checklist - StrongArm™ HVR303 Vehicle Restraint*”). The operator should fill out this form to keep a daily record of operation and maintenance issues.

9.3 ROUTINE SERVICING AND MAINTENANCE

Regular maintenance and care of the vehicle restraint is very important for cost, operation efficiency, and operator safety. A faulty vehicle restraint is a potential source of danger to the operator, and to other personnel working near it. As with all quality equipment, keep the vehicle restraint in good operating condition by following the recommended schedule of maintenance.

Failure to properly maintain or operate the dock leveler within its rated capacity can void the manufacturer warranty.

9.4 PLANNED MAINTENANCE PROGRAM INTERVALS

Arrange for a qualified vehicle restraint service technician to perform regularly scheduled planned maintenance on your vehicle restraint every three months for single shift operations or monthly for multi-shift operations. Call your authorized manufacturer or dealer for further details.

9.5 MAINTENANCE SEQUENCE

1. Cleaning, including pit area
2. Visual inspection of all components
3. Lubrication, as required (by a trained service technician only)
4. Test operate all functions
5. Adjustments, if required (by a trained service technician only)
6. Check for missing or damaged dock bumpers
7. Record inspection details and findings for owner's files

9.6 PMP CHECKLIST - STRONGARM™ HVR303 VEHICLE RESTRAINT

DANGER
When repairing or conducting maintenance procedures on electrical components, perform lockout / tagout steps according to OSHA regulations and approved electrical codes.

DANGER
Prior to installation, place adequate barriers to prevent unauthorized personnel and vehicle traffic from entering the work area.

WARNING
All repairs and maintenance work are to be conducted by trained and authorized personnel ONLY.

INSPECTED BY: _____ **DATE:** _____

SERIAL #: _____ **DOOR #:** _____

Forward this checklist to the person responsible for dock equipment maintenance. See Section 1.1 “Owner’s Purchase Record” for Date in Service.

INSTRUCTIONS FOR USE: Indicate “OK for USE” with a check mark ✓ in the appropriate box of each inspection point.

EVERY DAY:

- Remove any debris that may have accumulated around the dock equipment
- Check dock bumpers/extensions, wall cracks
- Check interior and exterior lights system
- Check exterior signage
- Check hydraulic hoses for leaks and/or damage
- Check safety warning decals and replace if necessary
- Verify complication-free operation of the Blue Genius™ Control Panel
- Verify complication-free operation of the dock equipment

EVERY 90 DAYS (30 DAYS FOR MULTI-SHIFT OPERATIONS)

- Perform all "every day" tasks
- Grease HVR303 rollers
- Check powerpack connections, motor and valves
- Inspect for damaged or missing parts, rust, corrosion, bent parts, cracks, etc.
- Check anchors

EVERY 90 DAYS CONT'D.

- Check junction box and control panel for proper and secure mounting. Verify that all electrical connections are firm
- Check hydraulic oil level in powerpack
- Check condition and torque on securing anchors, concrete conditions
- Verify that the proximity sensors are secure

ONCE A YEAR

- Drain, flush, and change the hydraulic reservoir as site / oil type dictate
- Remove the carriage assembly and inspect/lubricate any of the bearings

PHOTOCOPY THIS CHECKLIST AND FILL OUT REGULARLY FOR YOUR RECORDS.

Explain faults briefly in the space provided below:

10.0 RECOMMENDED SPARE PARTS

10.1 STANDARD OPERATIONAL COMPONENTS

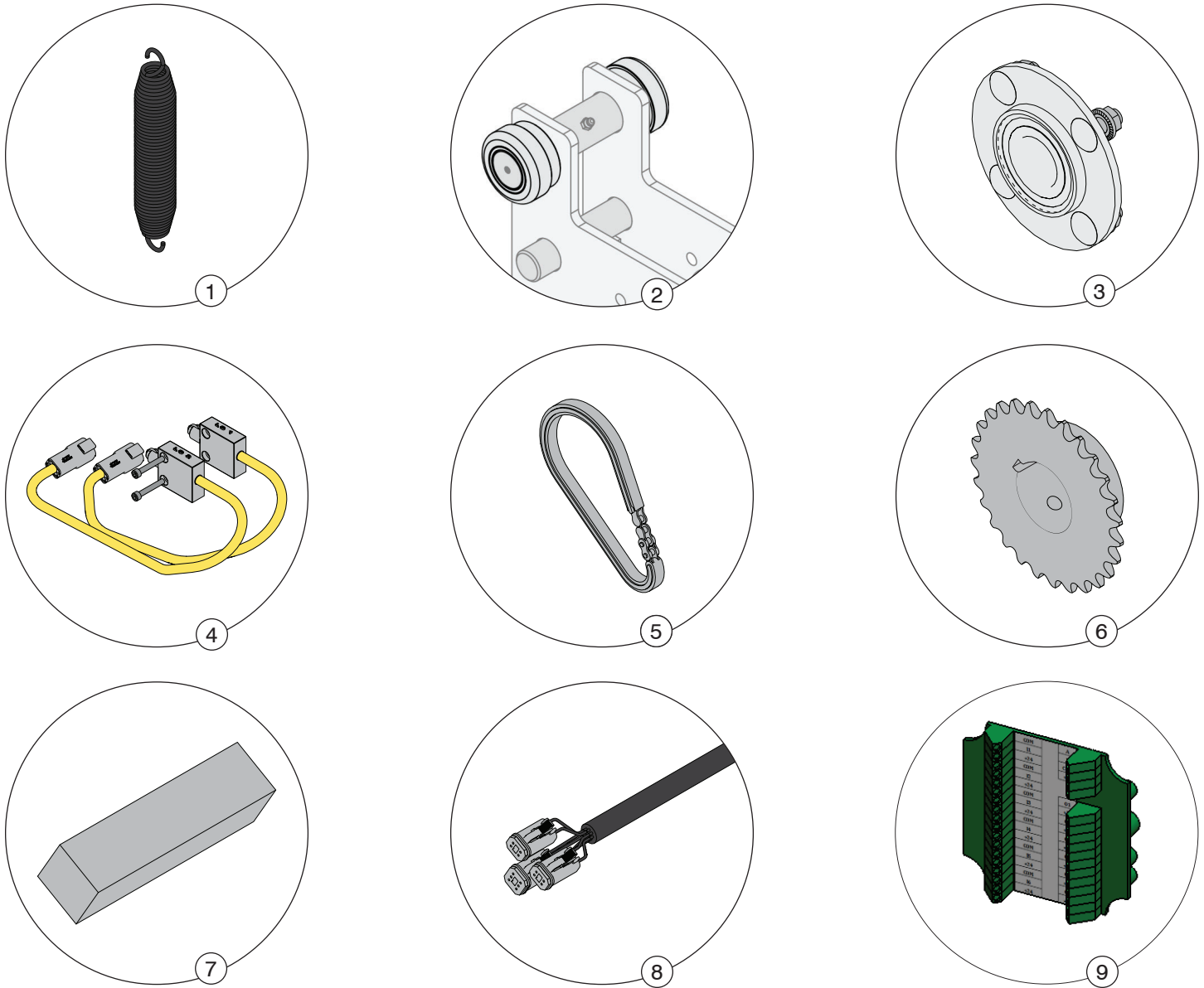

STANDARD OPERATIONAL COMPONENTS			
ITEM	PART NO.	DESCRIPTION	QTY REQ'D
1	56-010295-01	Extension Spring	4
2	019-034	Carriage Roller Housing with Bearing	4
3	56-010332	Y Bearing Assembly with Hardware	2
4	026-H19	Limit Switch with Connector	2
5	1005470	Roller Chain Assembly	1

STANDARD OPERATIONAL COMPONENTS			
ITEM	PART NO.	DESCRIPTION	QTY REQ'D
6	023-048	Chain Sprocket	1
7	118-755	Key 1/4 Square	3
8	026-H18	Harness with Cable and Connectors	1
9	026-G025M	Remote I/O Board (Resistor)	1

10.2 OPTIONAL SUPPORT COMPONENTS

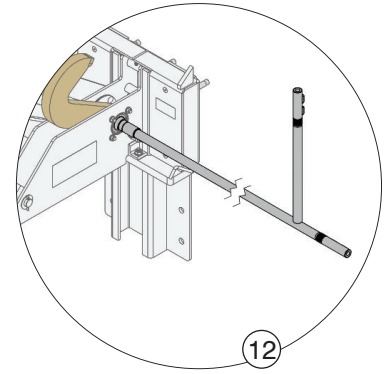
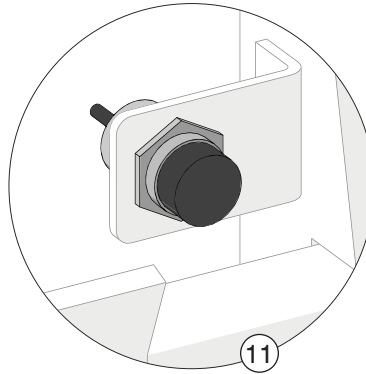
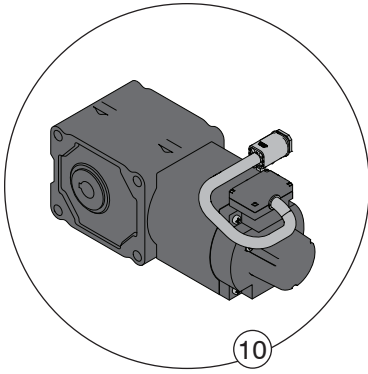

OPTIONAL SUPPORT COMPONENTS			
ITEM	PART NO.	DESCRIPTION	QTY REQ'D
10	1005476	Gear Motor Assembly with Cable and Connector	1
11	026-G019	Proximity Sensor (30mm Unshielded) Home/Lip Sensor	1
	026-M12-F5	5 Meter Cable for Proximity Sensor	1
	026-M12-F2	2 Meter Cable for Proximity Sensor	1
	21-002154	Bracket for Proximity Sensor	1
12	56-011930	Lock Manual Release Tool	1

11.0 DECAL IDENTIFICATION AND LOCATION

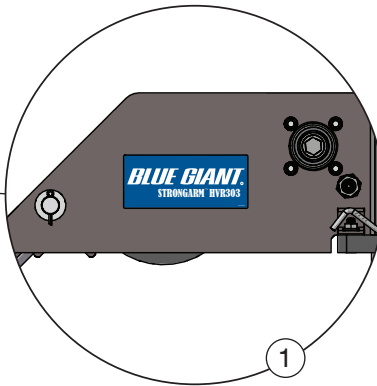
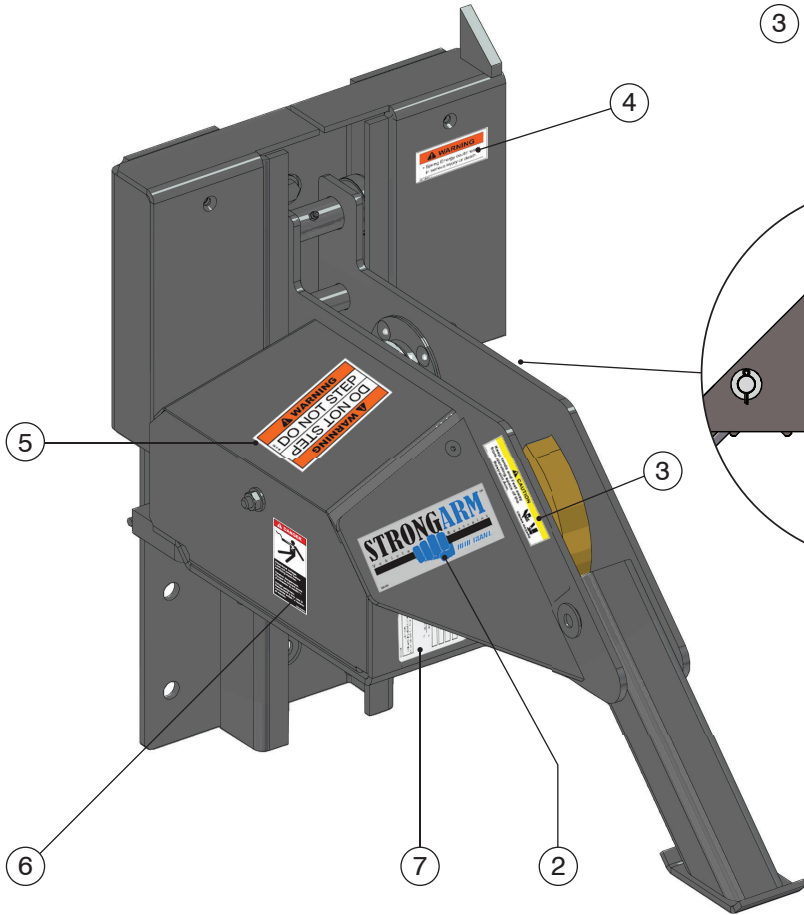

ITEM	QTY	PART NO.	DESCRIPTION		
1	1	038-846E	Decal - BG HVR303		
2	1	038-1187E	Decal - StrongArm - Vehicle Restraint		
3	1	038-243	<table border="1"> <tr><td>E</td></tr> <tr><td>F</td></tr> </table> Decal - Crush Hazard	E	F
E					
F					
4	1	038-048-2	Warning Decal - Springs Energy		
5	1	038-845	<table border="1"> <tr><td>E</td></tr> <tr><td>F</td></tr> </table> Warning Decal - Do Not Step	E	F
E					
F					
6	1	038-084EFS	Warning Decal - Hazardous Voltage		
7	1	038-299E	<table border="1"> <tr><td>F</td></tr> <tr><td>S</td></tr> </table> Decal - Serial Plate	F	S
F					
S					

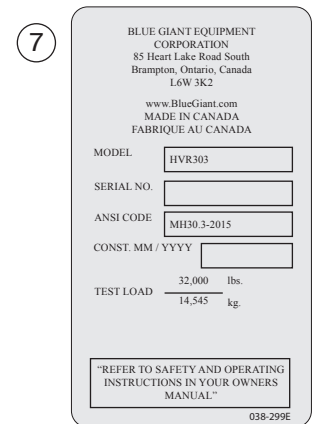
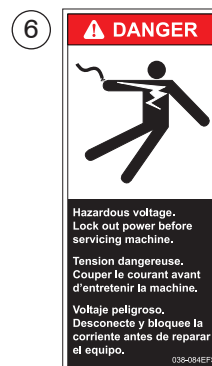

12.0 EQUIPMENT COMPONENT ILLUSTRATIONS

12.1 COMPONENTS AS SHIPPED CHECK LIST

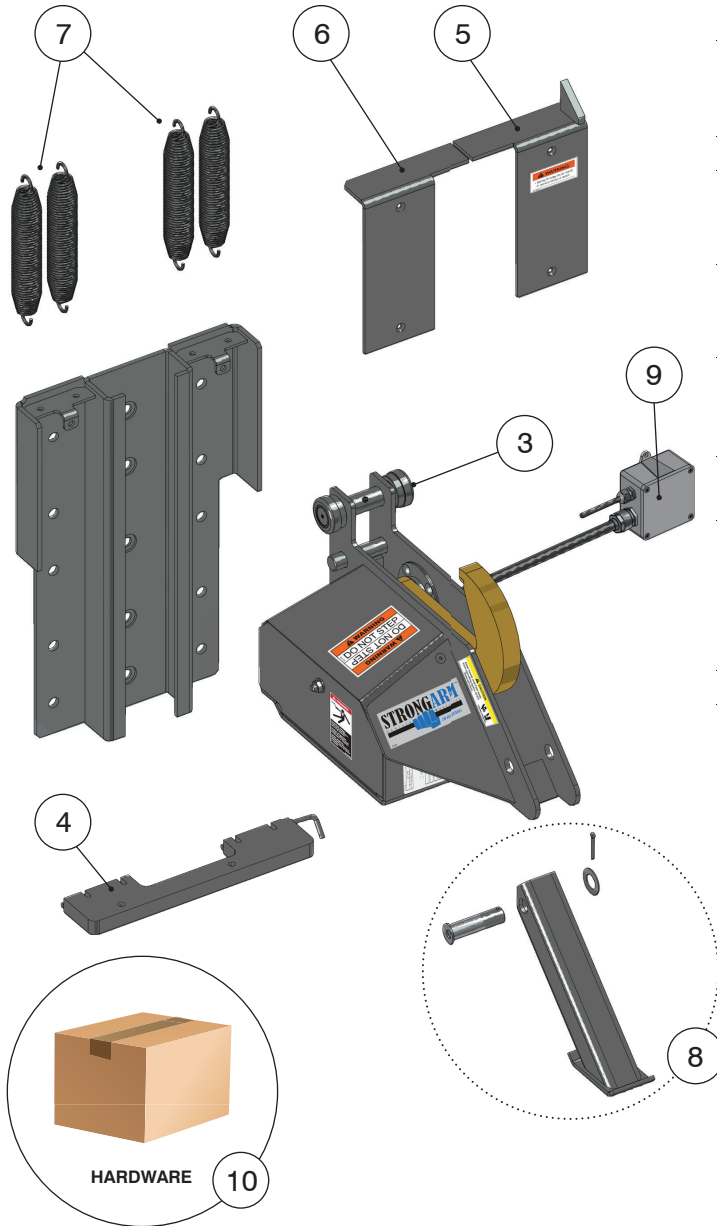

✓	ITEM	QTY	PART NO.	DESCRIPTION	APPROX. WEIGHT	
	1	1	56-010199	Roller Track Assembly	62 lb	28 kg
			56-010199-ZP	Roller Track Assembly, Zinc Plated		
	2	1	56-010197	Carriage Assembly	125 lb	57 kg
			56-010197-ZP	Carriage Assembly, Zinc Plated		
	3	4	019-034	Roller Assembly	3.2 lb	1.45 kg
	4	1	56-010193	Spring Bar Weld	12 lb	5.44 kg
			56-010193-ZP	Spring Bar Weld, Zinc Plated		
	5	1	56-010306	L Spring Cover Weld	6 lb	2.72 kg
			56-010306-ZP	L Spring Cover Weld, Zinc Plated		
	6	1	56-010304	R Spring Cover	5 lb	2.27 kg
			56-010304-ZP	R Spring Cover, Zinc Plated		
	7	4	56-010295-01	Extension Spring OD 1.875 x 10.75 long	2 lb	0.9 kg
	8	1	56-010320	Extension Arm Assembly	10 lb	4.5 kg
			56-010320-ZP	Extension Arm Assembly, Zinc Plated		
	9	1	56-010968	HVR J. Box Assembly	1 lb	0.45 kg



CONTROL AND COMPONENTS

ITEM # 11 - CONTROL AND COMPONENTS INCLUDED:

✓	QTY	PART NO.	DESCRIPTION	APPROX. WEIGHT		
	1	BGG0H1115F	Complete Control Assembly English / French	6.2 lb	2.81 kg	
		BGG0H1115S	Complete Control Assembly English / Spanish			
	1	032-806	Exterior Traffic Light	1.3 lb	0.6 kg	
	1	038-225	E	Exterior Driver Warning Sign	0.7 lb	0.32 kg
			F			
			S			
	1	026-G019	Dock Interlock (Lip Sensor)	0.4 lb	0.18 kg	
	1	026-M12-F5	5 Meter Cable for Proximity Sensor	—	—	
	1	026-M12-F2	2 Meter Cable for Proximity Sensor	—	—	
	1	21-002154	Mounting Bracket for Proximity Sensor	—	—	
	1	038-847E	Operation Placard	—	—	
	1	038-225	E	Owner's Manual (this one)	—	—
			F			
			S			
	1	038-225	EI	Installation Manual	—	—
	1	038-225	EPL	Parts List	—	—

ITEM # 10 - HARDWARE INCLUDED:

✓	QTY	PART NO.	DESCRIPTION	APPROX. WEIGHT	
	2	010-232	Socket Cap Screw 7/16"-14 x 1 1-2" L	1 lb	0.45 kg
	2	011-863	Serrated-Flange HEX. Nut 7/16" - 14		
	4	011-042	Cap Screw, HEX Socket F/H 5/16-18 x 1"		
	2	010-037	Cap Screw 5/16-18 x 3/4 HH GR. 5 ZC		
	2	012-200	Regular Spring Lock Washer 5/16"		
	15	010-239	Self Tapping Anchor	6 lb	2.72 kg
	1	56-010950	Junction Box with Remote I/O	0.8 lb	0.36 kg

12.2 MECHANICAL ASSEMBLY - 56-010200 / 56-010200-ZP

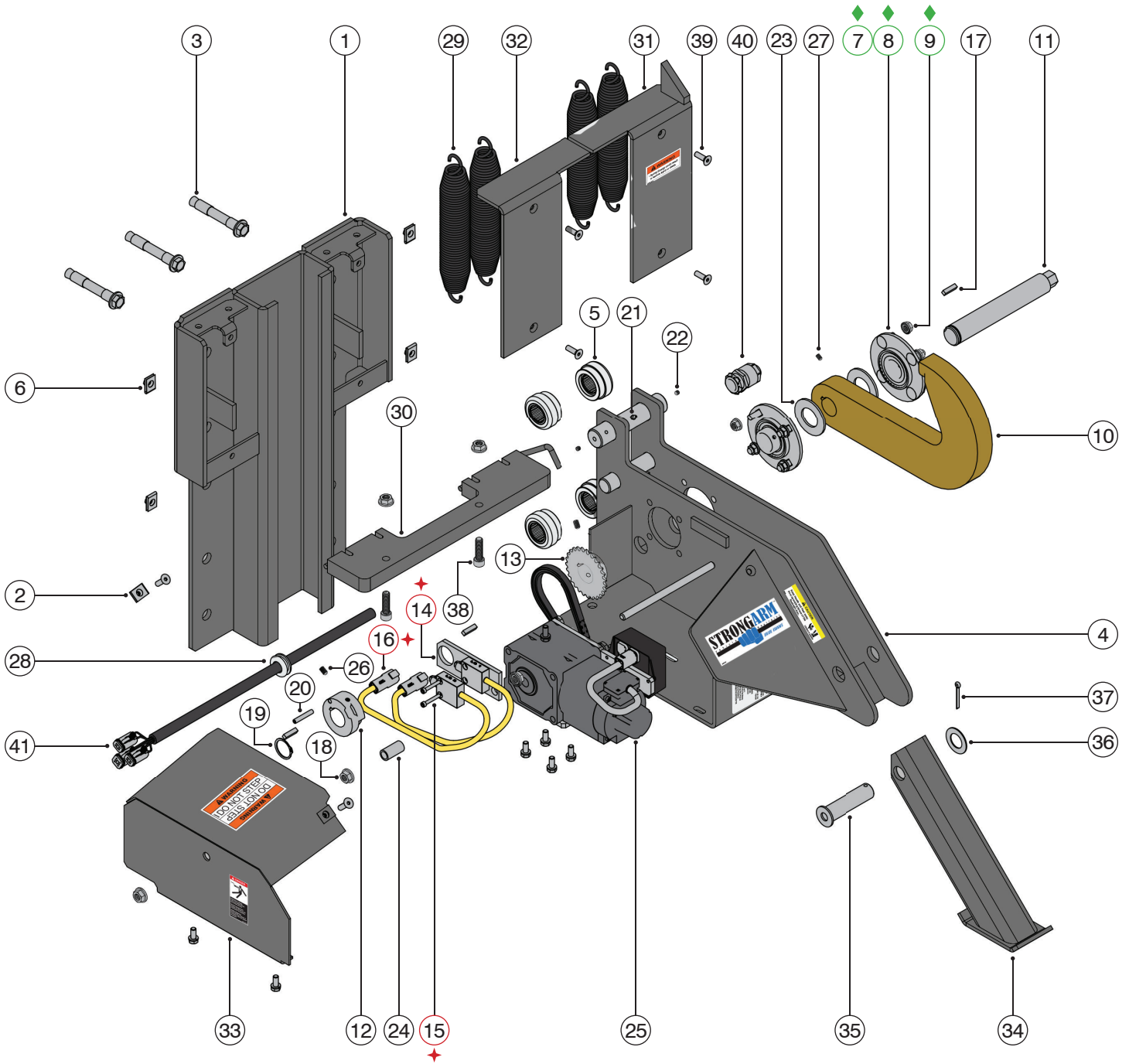

NOTE	PART NO.	DESCRIPTION
◆	56-010332	Bearing assembly includes parts highlighted
★	56-010390	Limit switch assembly includes parts highlighted

12.2 MECHANICAL ASSEMBLY - 56-010200 / 56-010200-ZP CONT'D.

ITEM	QTY.	PART NO.	DESCRIPTION	ITEM	QTY.	PART NO.	DESCRIPTION
1	1	56-010198	Roller Track Weld	22	4	014-013	Set Screw 1/4-28UNF x 1/4
		56-010198-ZP	Roller Track Weld, Zinc Plated	23	2	012-326	Flat Washer Type A - 1 3/8ID x 1/8THK
2	1	011-864	Cage Nut 5/16 UNC	24	1	56-010238	Limit Switch Tube
3	15	010-239	Self-Tapping Anchor	25	1	1005462	Gearmotor Assembly - See Section 12.4
4	1	56-010196	Carriage Weld	26	2	014-004	Setscrew, Socket - HD 5/16 x 1/2 UNC
		56-010196-ZP	Carriage Weld, Zinc Plated	27	1	014-002	Set Screw - 1/4" x 3/8" UNC.
5	4	019-034	Roller Assembly	28	1	037-053	Push-In Grommet - ID 3/4 x OD 1 1/16 x 1/4
6	4	011-864	Cage Nut 5/16 UNC	29	4	56-010295	Extension Spring OD 1.875 x 10.75 Long
◆ 7	4	018-646	Arm Bearing	30	1	56-010193	Springs Bar Weld
◆ 8	8	014-084	Carriage Bolt - 3/8 x 1 - GR5 - Zinc PL			56-010193-ZP	Springs Bar Weld, Zinc Plated
◆ 9	8	011-865	Serrated-Flange Hex. Nut 3/8"-16	31	1	56-010306	L Spring Cover Weld
10	1	56-011216	Hook Arm Weld			56-010306-ZP	L Spring Cover Weld, Zinc Plated
11	1	56-010140	Hook Shaft	32	1	56-010304	R Spring Cover
12	1	56-010237	Shaft Cam			56-010304-ZP	R Spring Cover, Zinc Plated
13	1	023-048	Chain Sprocket - ANSI #35B27 x BORE 1 1/4	33	1	56-010387	Motor Cover Assembly
+ 14	1	56-010175	Limit Switch Bracket			56-010387-ZP	Motor Cover Assembly, Zinc Plated
+ 15	2	011-094	SHCS 10-32 x 1 1/2"	34	1	56-010319	Extension Arm Weld
+ 16	2	026-H19	Limit Switch C/W Connector			56-010319-ZP	Extension Arm Weld, Zinc Plated
17	3	118-755	Key 1/4" Sq x 1" LG	35	1	56-010569	Extension Pin - Weld
18	5	011-863	Serrated-Flange Hex. Nut 7/16"-14	36	1	106-389	Spacer Washer
19	1	013-036	External Retaining Ring - ID 1.25	37	1	013-025	Cotter Pin 3/16" x 1.5"
20	1	013-625	Spring Pin 1/4" x 1 1/2" Long	38	2	010-232	Socket Cap Screw 7/16" - 14 x 1 1/2" L
21	2	019-500	Nipple Straight Grease 1/4"	39	5	011-042	Cap Screw, Hex Socket F/H 5/16 - 18 x 1"
				40	1	025-023	Fitting SR-75-625
				41	1	026-H18	Harness Cable - Assy

12.3 GENERAL DIMENSIONS

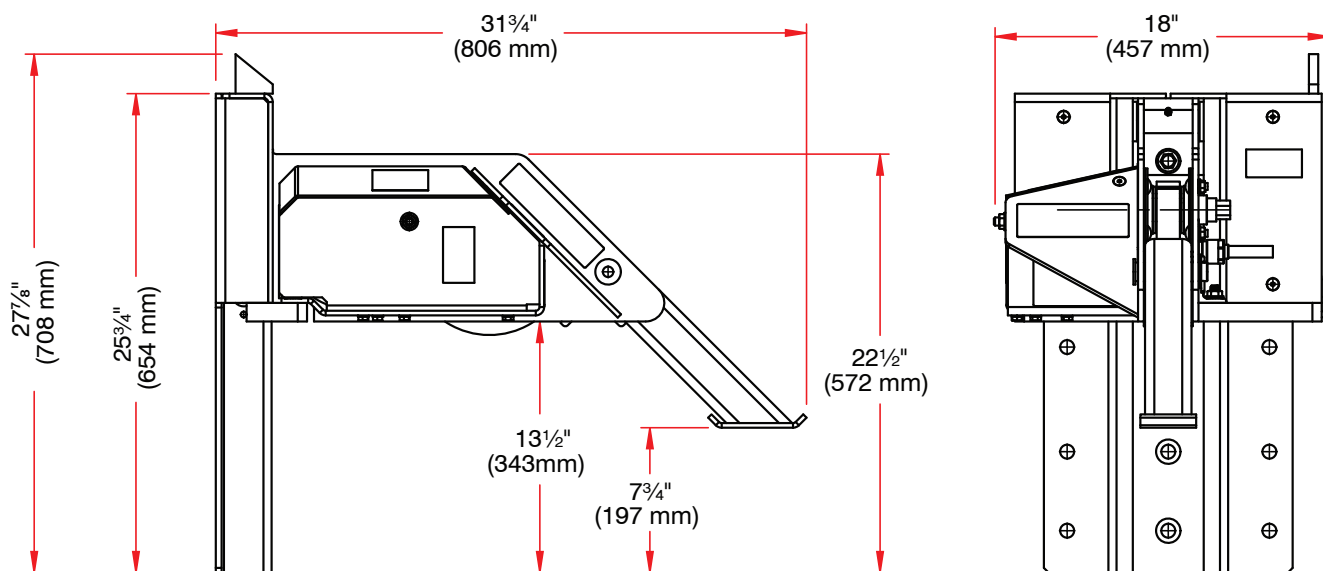

12.4 GEARMOTOR ASSEMBLY - 1005462

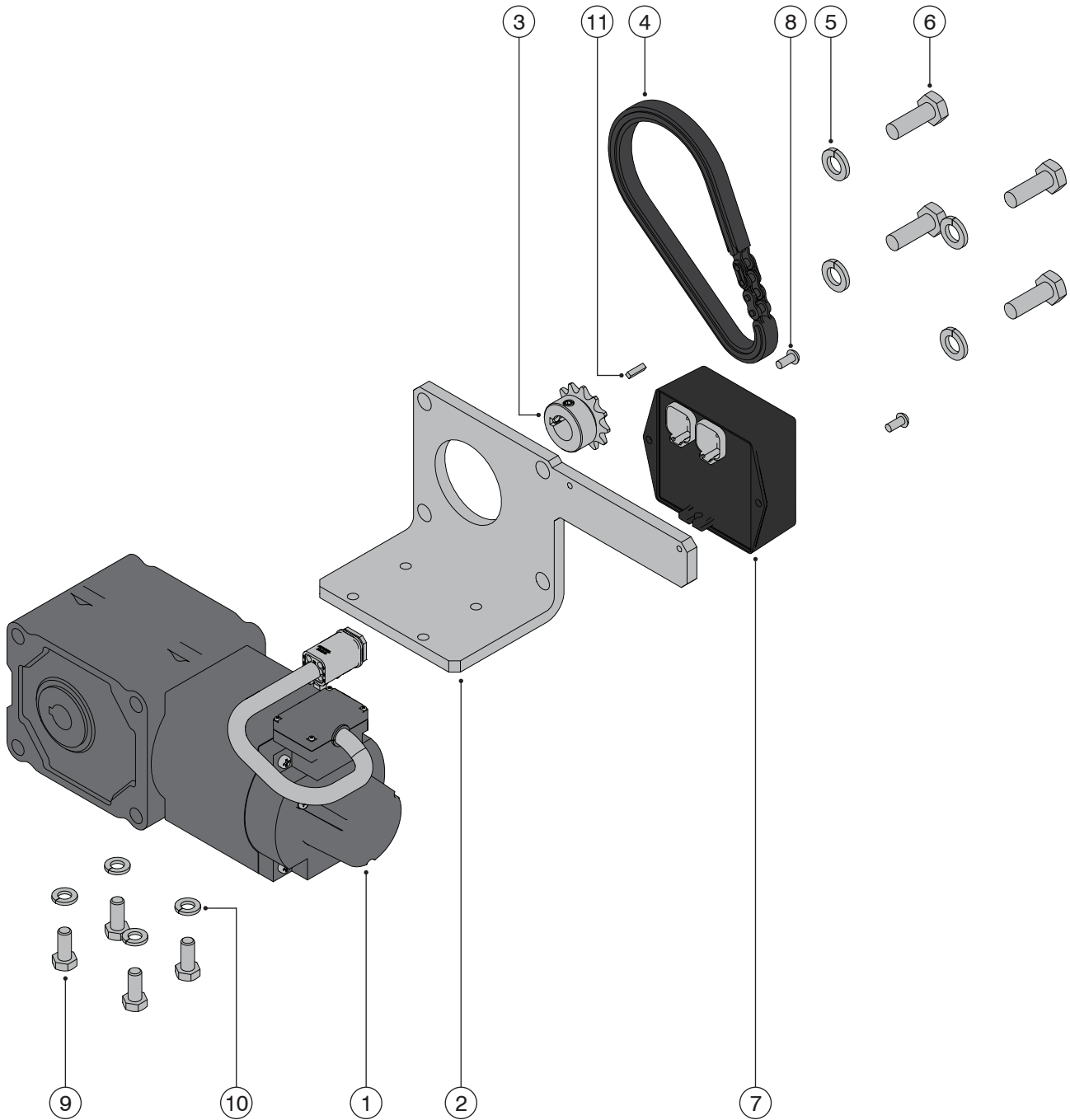

GEARMOTOR ASSEMBLY - 1005462

ITEM	QTY.	PART NO.	DESCRIPTION
1	1	1005476	Gearmotor with Cable and Connector
2	1	2000487	Gearmotor Bracket
3	1	023-049	Chain Sprocket
4	1	1005470	Roller Chain
5	4	012-228	Lockwasher Spring 7/16"
6	4	010-170	Hex Head Cap Screw M10x20 - GR 8.8

ITEM	QTY.	PART NO.	DESCRIPTION
7	1	026-G061-A	Gearmotor Controller Assembly
8	2	011-010	Machine Screw 10-24 x 3/8"
9	4	010-037	Hex Head Cap Screw 5/16-18 UNC x 3/4" L
10	4	012-200	Lockwasher Spring 5/16"
11	1	118-755	Key 1/4" Sq x 1" LG

12.5 CONTROLS

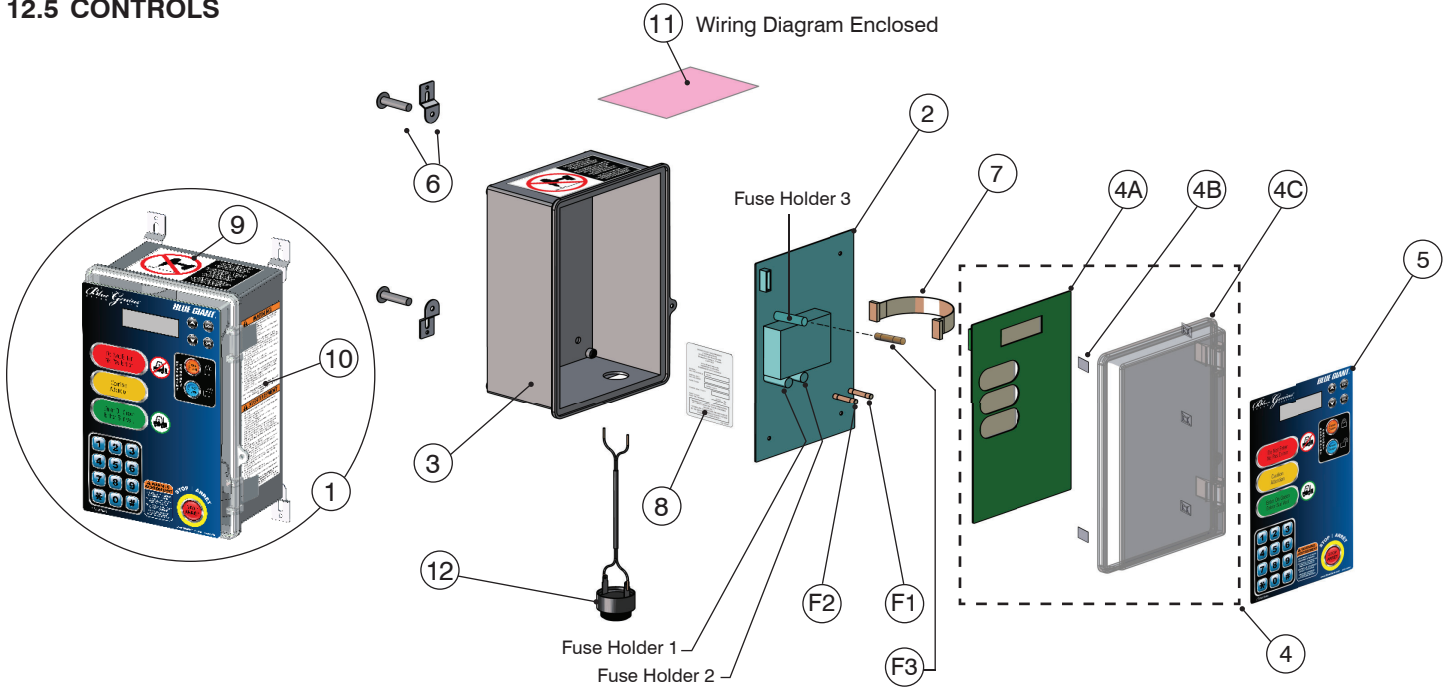

COMPLETE CONTROL STATION ASSEMBLY - ITEM 1 (Example BGG0H1115F)

ITEM	SINGLE PHASE						
	◇	FUSE	QTY	PART NO.	DESCRIPTION	ASSY PART #	*
2		F1	A	1	Power Board Sub-Assembly † (1PH 115V 50-60HZ)	BGG0H1115	F
		F2	E	1			S

AS PER VOLTAGE - SEE ITEM 1

ITEM	QTY	PART NO.	DESCRIPTION
A	1	026-G123	Fuse, 5A, 250V, Time Delay for 1PH, 110-130V
E	1	026-G104	Fuse, 0.75A, 250V, Time Delay for 1PH, 110-130V

ITEM	QTY	PART NO.	DESCRIPTION
3	1	025-G010-M	Control Box Enclosure (Includes 4C) Sub-Assembly † (1PH 115V 50-60HZ)
4	1	025-G014-V3-M	Transparent Cover Door (4C) and Touch Control Board (4A) (Serial # Required)
4A	1		Touch Control Board (Serial # Required)
4B	5		Cable Tie Mount
4C	1		Transparent Cover Door
5	1	038-245E	F S Face Decal
6	1	025-G010-1	Mounting Tabs with Hardware (1 pkg of 4)
7	1	026-G030	Ribbon Cable
8	1	038-284E	F S Decal, Serial Plate
9	1	038-283EFS	Decal, Do Not Drill
10	1	038-853EFS	Warning Decal
11	1	026-615-1	Anti-Static Poly Bag (Wiring Diagram Enclosed) (Serial # required for diagram)
12	1	026-G402	Audible Speaker
F3	1	026-237-1	Fuse, 2.5A, 250V, Fast Acting

* Language on decal: F = English / French S = English / Spanish
 ◇ Location on Power Board † Includes Fuses ‡ 115 Volt Control Box Shown

12.6 JUNCTION BOX W/REMOTE I/O

JUNCTION BOX ASSEMBLY PART # 51-010950			
ITEM	QTY	PART NO.	DESCRIPTION
1	1	025-G020-R	Junction Box 4" x 4"
2	1	026-G025M	Remote I/O Board (Resistor)
3	1	025-177	PG16 Metal Locknut
4	1	025-174	PG16 Cable Gland
5	1	025-179	PG16 Multi-Hole Seal
6	1	026-G031-C	Communication Cable Shielded - 15' (4.6 m)
7	1	026-6034-3600-1	7-Wire Cable (From Junction Box Assembly)

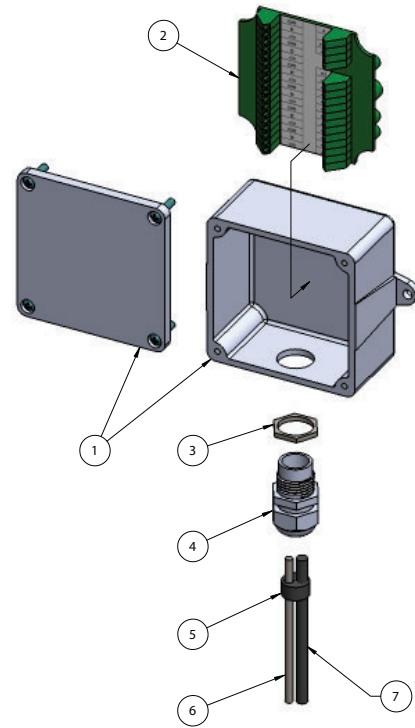

12.7 JUNCTION BOX ASSEMBLY

JUNCTION BOX ASSEMBLY PART # 56-010968			
ITEM	QTY	PART NO.	DESCRIPTION
1	1	025-G020-P	Junction Box 4" x 4"
2	1	025-172	Terminal Blocks 0.32" x 11"
3	1	025-016	Fitting SR-50-625 3/4"
4	1	025-173	PG9 Cable Gland
5	1	025-176	PG9 Metal Locknut

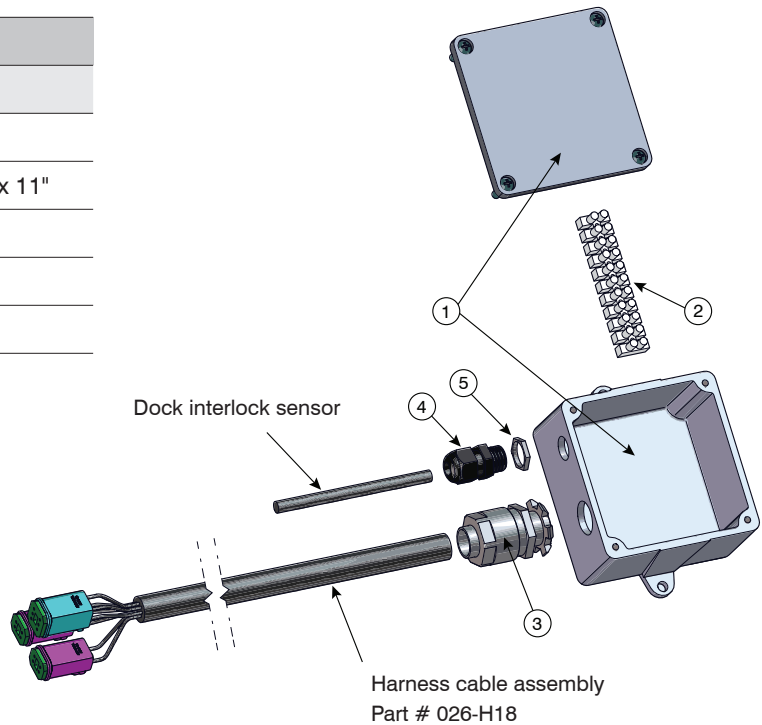

12.8 DOCK INTERLOCK SENSOR

- Ties sequence of vehicle restraint to dock leveler operation
- Loading dock safety is improved with accurate operation sequence
- Interior traffic light and vehicle restraint release operation relies on interlock capability
- Mounted at parked position of any leveler

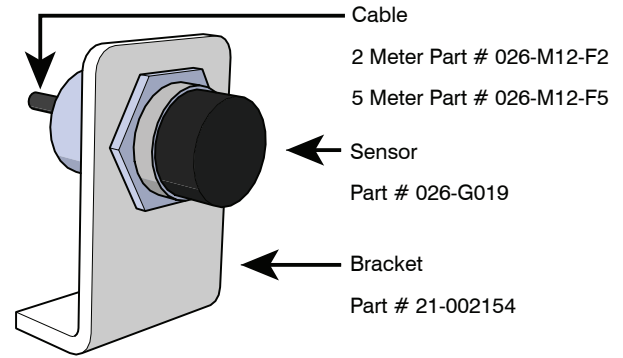

12.9 EXTERIOR TRAFFIC LIGHT / MIRROR IMAGE SIGN

Slim-build LED traffic lights and mirror image driver warning sign improve loading dock safety.

The LED traffic lights and mirror image drive warning sign improve loading dock safety.

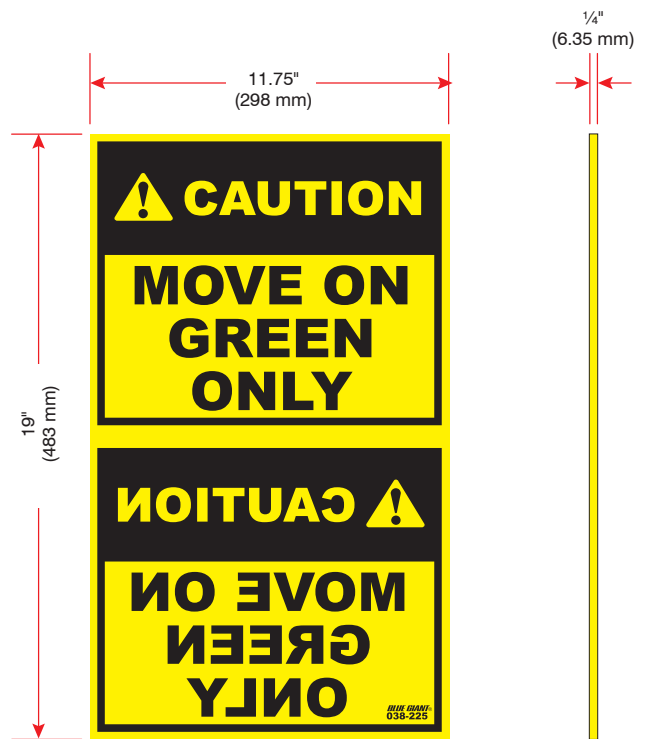
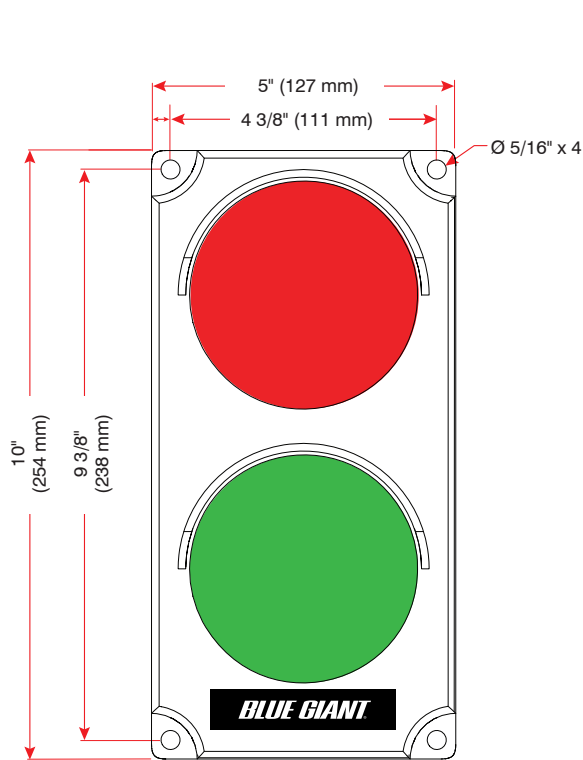

Exterior driver traffic light, part # 032-806.

NOTE: Mount to a flat surface. DO NOT deform light housing with irregular wall surface.

Exterior driver warning sign, part # 038-225 (French 038-225F / Spanish 038-225S).

13.0 VEHICLE RESTRAINT TROUBLESHOOTING

⚠	WARNING
<p>Do not attempt to install, make repairs or adjustments. Only a trained and authorized service technician should perform the installation process. Contact your local dealer or distributor for assistance.</p>	

PROBLEM	PROBLEM CAUSE
<p>The restraint hook will not rise when the ENGAGE button is touch.</p>	<ol style="list-style-type: none"> 1. Faulty wiring, connection or broken wire. Refer to electrical wiring diagram section 8.1. 2. Power source problem. Check incoming voltage and compare to data nameplate voltage. 3. Restraint apparatus is seized. Check for foreign objects such as broken wooden pallet splitters. 4. Motor clutch is out of adjustment. Tighten to required specs. 5. The controls are in bypass mode. Press RELEASE button and then ENGAGE button. 6. Chain drive assembly is broken. Check for broken chain or missing keyways in either sprocket. 7. Restraint option not chosen in menu. 8. Drive motor is faulty. 9. M1 and M2 reversed.
<p>The restraint hook will not lower when the RELEASE button is pushed.</p>	<ol style="list-style-type: none"> 1. Faulty wiring or connections. Refer to electrical wiring diagram section 8.1. 2. Hook was improperly engaged. 3. Motor clutch is out of adjustment. Tighten to required specs. 4. Chain drive assembly is broken. Check for broken chain or missing keyways in either sprocket. 5. Restraint apparatus is blocked from coming down. Check for foreign objects.
<p>Restraint works but LED cover lights are not lit. LCD display is working.</p>	<ol style="list-style-type: none"> 1. Power source for lights is damaged. Replace control board.
<p>Exterior traffic lights are dim, displaying incorrectly (wrong color) or malfunctioning (only one light works).</p>	<ol style="list-style-type: none"> 1. Check wiring to lights. Ensure that the red outside light is connected to terminal # 12 on the control strip label 1 to 14 and that the green light is connected to terminal #13 and the COM of the lights are connected to terminal #14 of the Blue Genius™ control panel. 2. Lights COM wire is terminated in wrong terminal (other than #14).
<p>The restraint is in the parked position and the inside light is green with flashing yellow.</p>	<ol style="list-style-type: none"> 1. The restraint is in the bypass mode and the lip sensor is not active.
<p>Restraint body is not in its home position.</p>	<ol style="list-style-type: none"> 1. One or more extension springs have broken or come off their mounts. 2. Foreign debris is jamming the body from retracting to the home position. 3. Main channel weldment is damaged from misuse. 4. Lag mounting bolt is obstructing carriage movement.
<p>Hook moves in one direction only.</p>	<ol style="list-style-type: none"> 1. Motor is not connected properly to terminal strip. Check wiring diagram section 8.1. 2. Motor has an open winding. Replace motor. 3. Bad contactor, replace power board.

PROBLEM	PROBLEM CAUSE
The restraint is powered on. After the self test sequence, the LCD screen displays the message 'Restraint is Bypassed'. The control panel lights are green and flashing yellow while the outside traffic light is red.	<ol style="list-style-type: none"> 1. The dock leveler is not parked. 2. Home sensor not installed. 3. Home sensor does not detect the dock leveler as being in the parked position. 4. Home sensor miswired / defective.

14.0 BLUE GENIUS™ LCD MESSAGES

WARNING

Do not attempt to install, make repairs or adjustments. Only a trained and authorized service technician should perform the installation process. Contact your local dealer or distributor for assistance.

MESSAGE	EXPLANATION
'Fault 10' code appears on LCD screen after successful power up.	<ol style="list-style-type: none"> 1. Restraint communication was lost after the successful power-up report. Check communication routing of wiring to remote input/output board (I/O).
Arm is blocked message appears on LCD display and home sensor is inactive.	<ol style="list-style-type: none"> 1. Turn power off and check hook for foreign debris caught in the restraint apparatus pathway to home position. 2. Check to see if chain has broken. Chain repairs must be performed by a qualified technician. 3. The ICC bar of the truck is preventing the hook from dropping. Back truck up.
'Restraint is Engaged'	<ol style="list-style-type: none"> 1. The 'Engage' button has been touched. The vehicle restraint is in the locked position.
'Ready to Release'	<ol style="list-style-type: none"> 1. The dock leveler has been properly parked. The operator can now release the vehicle restraint.
Blue Genius WARNING followed by ' Restore Restraint ' and then ' Press SEL to Continue ' (Message repeats).	<ol style="list-style-type: none"> 1. Apparatus is blocked in range sensor's in-active range. Perform a visual check on the ICC bar status and reposition the truck if necessary. 2. Check to see if chain has broken. Chain repairs must be performed by a qualified technician.
During power up self-test, LCD message reads " SELF TEST " " Remote I/O Bad ".	<ol style="list-style-type: none"> 1. During the self-test the system has detected that a wire/s is not connected to the communication terminal(s). 2. Remote I/O board is faulty. Replace. 3. Power board is faulty. Replace.
"Fault 11"	<ol style="list-style-type: none"> 1. HVR303 Switch Fault: Home and in range active at the same time.

15.0 WIRING DIAGRAM

NOTICE

The following wiring diagrams are sample configurations only. Wiring diagrams specific to your needs will be provided inside the control panel and/or as part of your submittal package.

15.1 WIRING DIAGRAM—115V SINGLE PHASE

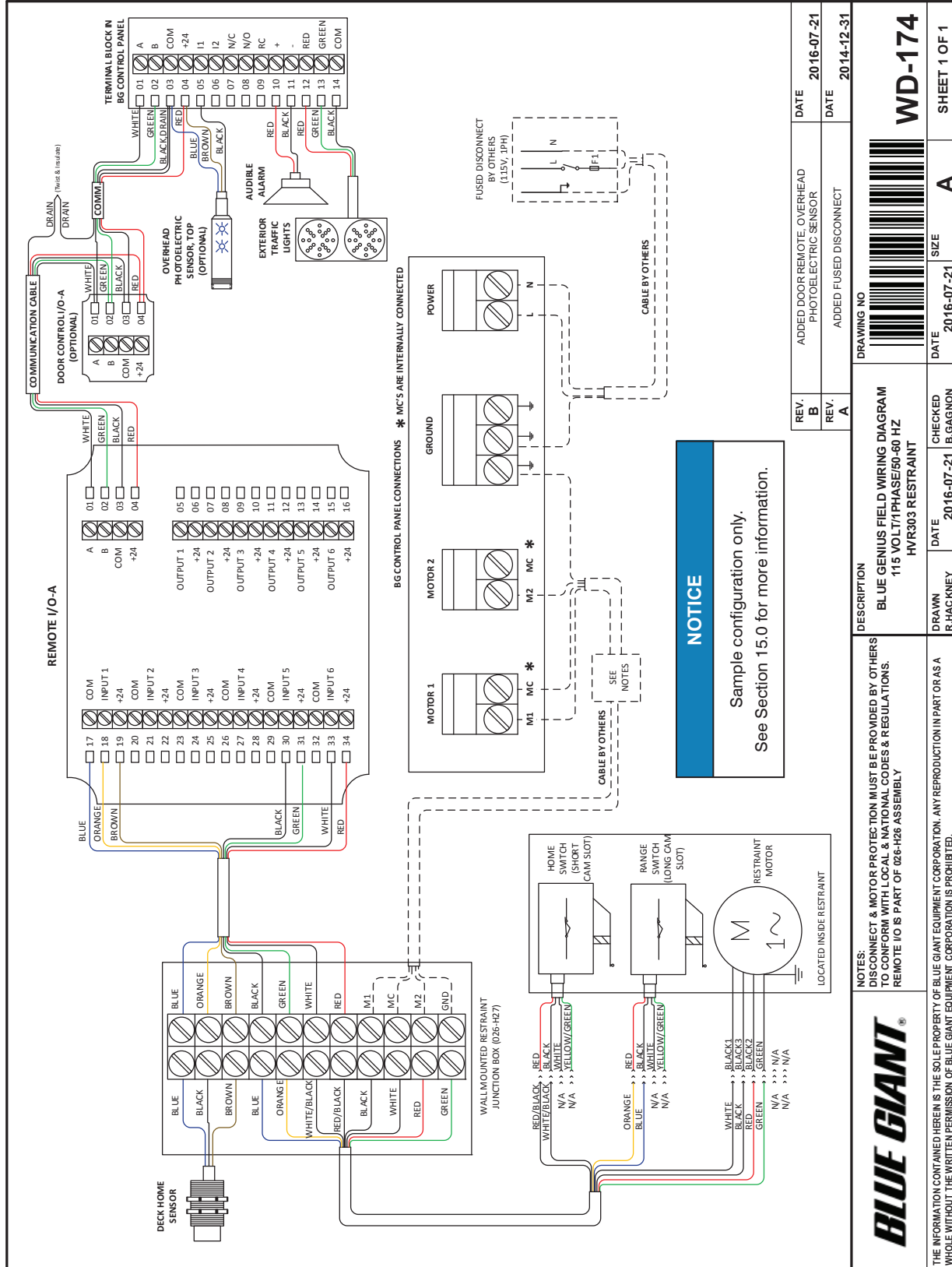

NOTES

NOTES

BLUE GIANT[®]
BLUE GIANT EQUIPMENT CORPORATION

Corporate 410 Admiral Blvd
Mississauga, ON, Canada L5T 2N6
t 905.457.3900 f 905.457.2313

USA 6350 Burnt Poplar Road
Greensboro, NC 27409
www.bluegiant.com