

# OWNER'S MANUAL

## STRONGARM™ SVR303 VEHICLE RESTRAINT WITH BLUE GENIUS™ TOUCH CONTROL



ACTUAL PRODUCT MAY NOT APPEAR EXACTLY AS SHOWN



### WARNING

Do not operate or service this product unless you have read and fully understand the entire contents of this manual. Failure to do so may result in property damage, bodily injury or death.

**BLUE GIANT**®

**TABLE OF CONTENTS**

<b>1.0</b>	<b>ABOUT THE STRONGARM™ SVR303 WITH BLUE GENIUS™ TOUCH CONTROL</b>	<b>4</b>
1.1	OWNER'S PURCHASE RECORD	4
<b>2.0</b>	<b>INTRODUCTION</b>	<b>5</b>
2.1	WARRANTY INFORMATION	5
2.2	EXCLUSION OF LIABILITY	5
2.3	MANUFACTURER'S NOTE	5
2.4	OWNER'S RESPONSIBILITY	6
<b>3.0</b>	<b>OPERATOR'S MANUAL SAFETY MESSAGE COLOR IDENTIFICATION</b>	<b>7</b>
3.1	OPERATIONAL SAFETY WARNINGS	7
<b>4.0</b>	<b>LOCKOUT / TAGOUT PROCEDURE AND RULES</b>	<b>8</b>
<b>5.0</b>	<b>EMERGENCY VEHICLE RESTRAINT LOWERING PROCEDURE</b>	<b>8</b>
<b>6.0</b>	<b>CONTROL PANEL OPERATION</b>	<b>9</b>
6.1	BUTTON FUNCTION	9
<b>7.0</b>	<b>OPERATING INSTRUCTIONS</b>	<b>10</b>
7.1	FUNCTIONAL DESCRIPTION	10
7.2	STOP BUTTON FUNCTION	11
7.3	PRIOR TO USE: EQUIPMENT IN STORED POSITION	11
7.4	TRAILER AT BAY	12
7.5	ENGAGING RESTRAINT	12
7.6	DEPLOYING THE DOCK LEVELER	13
7.7	RELEASING THE RESTRAINT ARM	13
<b>8.0</b>	<b>ENGAGING THE OVERRIDE FEATURE</b>	<b>14</b>
8.1	RELEASING THE OVERRIDE FEATURE	15
<b>9.0</b>	<b>MAINTENANCE</b>	<b>16</b>
9.1	PLANNED MAINTENANCE PROGRAM (PMP)	16
9.2	OPERATOR DAILY INSPECTION	16
9.3	ROUTINE SERVICING AND MAINTENANCE	16
9.4	PLANNED MAINTENANCE PROGRAM INTERVALS	16
9.5	MAINTENANCE SEQUENCE	16
9.6	RECOMMENDED HYDRAULIC FLUIDS	16
9.7	PMP CHECKLIST - STRONGARM™ SVR303 VEHICLE RESTRAINT	17
<b>10.0</b>	<b>RECOMMENDED SPARE PARTS</b>	<b>18</b>
10.1	STANDARD OPERATIONAL COMPONENTS	18
10.2	COMPONENT SHIELDS	19
10.3	OPTIONAL SUPPORT COMPONENTS	19
<b>11.0</b>	<b>DECAL IDENTIFICATION AND LOCATION</b>	<b>20</b>
<b>12.0</b>	<b>EQUIPMENT COMPONENT ILLUSTRATIONS</b>	<b>21</b>
12.1	COMPONENTS AS SHIPPED CHECKLIST	21

**TABLE OF CONTENTS CONT'D.**

12.2	MECHANICAL ASSEMBLY - 54-010980 AND 54-010980-ZP	22
12.3	GENERAL DIMENSIONS	23
12.4	RESTRAINT ARM SENSOR ASSEMBLY	24
12.5	POWERPACK PART IDENTIFICATION	25
12.6	CONTROLS	26
12.7	JUNCTION BOX W/REMOTE I/O	27
12.7.1	JUNCTION BOX DIMENSIONS	27
12.8	RESTRAINT INTERLOCK SENSOR	28
12.9	EXTERIOR TRAFFIC LIGHT / MIRROR IMAGE SIGN	28
13.0	<b>VEHICLE RESTRAINT TROUBLESHOOTING</b>	29
14.0	<b>BLUE GENIUS™ LCD MESSAGES</b>	30
15.0	<b>WIRING DIAGRAMS</b>	30
15.1	WIRING DIAGRAM—115V SINGLE PHASE	31
15.2	WIRING DIAGRAM—230V SINGLE PHASE	32
15.3	WIRING DIAGRAM—208-600V THREE PHASE	33

## 1.0 ABOUT THE STRONGARM™ SVR303 WITH BLUE GENIUS™ TOUCH CONTROL

The Blue Giant StrongArm™ SVR303 applies 35,000 lb (15,876 kg) of restraining force to prevent trailer creep, unscheduled departures, and other hazards caused by trailer movement. With a vertical restraining range of 8" (203mm) to 26" (660mm) and horizontal reach of 13" (406mm), this award-winning hydraulic vehicle restraint will secure virtually any truck or trailer, even those with bent or damaged ICC bars.

The SVR303 Intelligent Positioning System (IPS) uses switchless technology to detect an ICC bar. The unique mechanical PosiLock configuration keeps trailers in place without applying pressure to the hydraulic system. Additional operational features include:

- Air-ride compatibility
- NEMA 6 IPS sensor and double-acting cylinders that enable operation even during wet or flooded conditions
- Restraint arm removes obstacles in its travel path, ensuring smooth and trouble-free deployment and parking

The Blue Genius™ Gold Series II Touch Control Panel features include an LCD menu screen, function (ENGAGE, RELEASE, STOP) buttons and a flat-surface keypad with unique touch sensors. LED control panel lights and LED exterior traffic lights keep truck drivers and warehouse personnel advised of safety conditions during dock operations.

## 1.1 OWNER'S PURCHASE RECORD

<b>OWNER'S PURCHASE RECORD</b>	
Please record information for future inquiries and to validate warranty. (See Section 2.1 for warranty validation)	
<b>Dealer:</b>	<b>Date in Service:</b>
	<b>Number of Units:</b>
<b>Serial Number:</b>	<b>Door #:</b>
<b>Serial Number:</b>	<b>Door #:</b>
<b>Serial Number:</b>	<b>Door #:</b>
<b>Serial Number:</b>	<b>Door #:</b>
<b>Serial Number:</b>	<b>Door #:</b>
<b>Serial Number:</b>	<b>Door #:</b>
<b>Serial Number:</b>	<b>Door #:</b>

The manufacturer offers a full line of dock levelers, dock safety equipment, accessories, ergonomic and scissor lift equipment, seals and shelters, and industrial trucks. Concurrent with a continuing product improvement program, specifications are subject to change without notice (see Section 2.2 of this manual). Please contact the manufacturer for latest information. Some features illustrated may be optional in certain market areas.

NOTICE
See Section 11.0 "Decal Identification and Location," item #6 for serial number location.

## 2.0 INTRODUCTION

The following is a quick reference to important procedures that must be followed while using the Vehicle Restraint System. It is not intended to cover, or suggest that it does cover, all procedures necessary to ensure safe operation. All operators should be aware of and abide by all workplace safety regulations applicable to the operation of the Vehicle Restraint System. These laws and regulations include but are not limited to:

- The Occupational Safety and Health Act
- Canada Occupational Health and Safety Regulations
- Occupational Safety and Health Acts for Individual States (USA)

For additional information on these regulations as well as industry standards that may apply to this product, please contact:



American National Standards Institute (ANSI)  
 1430 Broadway  
 New York, NY 10018  
 Telephone: 212.642.4900  
 www.ansi.org

Also a member of:



Loading Dock Equipment Manufacturers  
 A Product Section of Material Handling Industry of America  
 A Division of Material Handling Industry  
 8720 Red Oak Blvd, Suite 201  
 Charlotte, NC, 28217-3992  
 Telephone: 704.676.1190  
 www.mhi.org/lodem

## 2.1 WARRANTY INFORMATION

Thank you for purchasing Blue Giant products. We appreciate your business, and are confident that our product will serve you for many years to come. In the event that you experience a problem with our product, our Warranty Center is here to support the Blue Giant Product(s) that you have purchased.

To validate warranty on recently purchased equipment, please complete and submit your information with our on-line Warranty Registration at [www.BlueGiant.com](http://www.BlueGiant.com).

For more information about Blue Giant Warranty Support, please contact your local Blue Giant Equipment dealer, representative or authorized partner near you. You may also visit [www.BlueGiant.com](http://www.BlueGiant.com) or phone 1.905.457.3900.

### DEALER INFORMATION

Name:

Contact:

Telephone:

**NOTE:** All products must be registered to qualify for warranty.

## 2.2 EXCLUSION OF LIABILITY

The manufacturer assumes no liability for damage or injury to persons or property which occur as a result of defects or faults in or incorrect use of the Vehicle Restraint System. The manufacturer also assumes no liability for lost profits, operating downtimes, or similar indirect losses incurred by the purchaser. Injury to third parties, irrespective of its nature, is not subject to compensation.

The manufacturer reserves the right to make changes at any time to the modules, components, and accessories, concurrent with its continuing product improvements and development program. Specifications, operating instructions, and illustrations included in this manual are subject to change without notice. Please contact manufacturer for the latest information.

## 2.3 MANUFACTURER'S NOTE

The Vehicle Restraint has been carefully inspected and tested at the manufacturer's plant prior to shipment, but should be checked upon receipt for transport damage. Any observed transport damage is to be listed on the signed copy of the freight document. Notify the freight forwarder of any damage WITHIN 48 HOURS.

## 2.4 OWNER'S RESPONSIBILITY

1. The owner should recognize the inherent danger of the interface between the dock and the freight carrier. The owner should, therefore, train and instruct operators in the safe use of the dock equipment and accessories in accordance with the manufacturer's recommendations.
2. The owner should thoroughly familiarize themselves with the following procedures and specifications, and request immediate replacement of all manufacturer-supplied documents that are missing, damaged, or otherwise illegible.
  - Installation instructions
  - Operating instructions
  - Planned maintenance procedures
  - Inspections procedures
  - Replacement parts lists

Upon receipt of any newly purchased dock equipment, the owner shall verify the presence of owner's manuals, operating placards, and any other documentation necessary for training dock personnel how to use the equipment safely and effectively.

3. Manufacturer's recommended periodic maintenance and inspection procedures shall be followed, and written records of the performance of these procedures should be kept as per warranty guidelines.
4. Dock equipment that is structurally damaged, experiencing performance irregularities, or has been potentially compromised (i.e. sudden loss of support due to premature truck departure) shall be removed from service until a trained and authorized manufacturer's representative can conduct an inspection and perform any necessary repairs.
5. As with any piece of machinery, dock equipment requires routine maintenance, lubrication, and adjustments. Your local Blue Giant® representative offers owners the option of a Planned Maintenance Program (P.M.P). As part of this service, your local Blue Giant® representative will do all routine maintenance, lubrication, and adjustments.
6. The owner shall ensure that all nameplates, caution/

instruction markings or labels are in place and legible, and that the appropriate operating/maintenance manuals are provided to authorized users. Replacement name plates, caution/instruction labels, and manuals containing operating and maintenance instructions are available through the Blue Giant Aftermarket Department. See Section 11.0 "*Decal Identification and Location*" for more information.

7. Modifications or alterations of dock equipment shall be made only with written permission of the original manufacturer. These changes shall also satisfy all safety recommendations of the original equipment manufacturer for the particular application of the dock equipment.
8. The owner or a trained and authorized representative shall verify that all freight carrier brakes have been applied and a vehicle restraint and/or wheel chocks properly engaged before cross-docking procedures such as loading and unloading begin.
9. Unless specifically agreed to in writing by Blue Giant Equipment Corporation at the time of order (and prior to manufacture), all Blue Giant Dock equipment is sold as a complete offering, and must not be altered or added to in any manner (which includes configuration and function) without written permission from an authorized manufacturer's representative.
10. If, at the request of the owner, Blue Giant does not supply all or some of the dock equipment power unit and/or control panel components, the owner shall assume responsibility for any and all operational and safety issues associated with the resulting configuration.

### 3.0 SAFETY MESSAGE COLOR IDENTIFICATION

This manual includes color-coded safety messages that clarify instructions and specify areas where potential hazard exists. To prevent the possibility of equipment damage and serious injury or death, please observe strictly the instructions and warnings contained in the messages. If warning decals become damaged or missing, replace them immediately. Avoid accidents by recognizing dangerous procedures or situations before they occur.

<b>⚠ DANGER</b>	<b>NOTICE</b>
Serious injury or death will likely occur if the instructions are not followed.	Procedures marked notice must be followed in order to prevent damage to machinery.
<b>⚠ WARNING</b>	<b>⚠ CAUTION</b>
Serious injury or death may occur if the instructions are not followed.	Instructions marked caution concern safe operating procedure. Failure to comply may result in personal injury.

### 3.1 OPERATIONAL SAFETY WARNINGS

<b>⚠ DANGER</b>	
<p><b>Keep hands and feet away from operating space of the restraint apparatus.</b></p> <p><b>CRUSH HAZARD</b></p> 	<ol style="list-style-type: none"> <li>1. Do not operate the dock equipment while anyone is standing in its path.</li> <li>2. Lift the dock equipment with suitable hoisting equipment only. Do not stand under the dock equipment or any heavy object while it is being hoisted.</li> <li>3. <b>BEFORE BEGINNING ANY SERVICE PROCEDURES:</b> Disconnect the power and follow all lockout / tagout procedures outlined in this manual.</li> </ol>
<b>⚠ WARNING</b>	
<ol style="list-style-type: none"> <li>1. Installation must be performed only by trained and authorized personnel.</li> <li>2. Prior to installation, place adequate barriers to prevent vehicle traffic from entering the work area.</li> <li>3. During installation, anchors must be properly torqued to achieve the necessary anchoring strength. <b>DO NOT USE IMPACT DRIVERS.</b></li> <li>4. Any electrical work must be performed by qualified personnel only.</li> <li>5. Do not remove the wheel chocks until loading /unloading is finished and the truck is cleared for departure or the vehicle restraint has been released and the lights have changed to RED inside and GREEN outside.</li> </ol>	
<b>NOTICE</b>	
<ol style="list-style-type: none"> <li>1. Do not ground welding equipment to any electrical components.</li> <li>2. Do not allow the drill to go too deeply into the control box, as damage may occur to the control systems.</li> <li>3. Never use air to blow debris from the control box. Use a vacuum to perform any necessary cleaning.</li> <li>4. Do not connect green ground lead into control box or junction box until all welding has been completed.</li> <li>5. If an extension plate / box is required, securely mount it on the restraint with hardware provided before shimming and drilling.</li> <li>6. Improper adjustments and / or lubrication may cause operational problems with equipment.</li> <li>7. Check hydraulic fluid level.</li> <li>8. Do not force the valve adjustment screws against the internal stops.</li> </ol>	
<b>⚠ CAUTION</b>	
<ol style="list-style-type: none"> <li>1. Only trained personnel should operate or service this equipment.</li> <li>2. Do not operate the dock equipment until the transport vehicle is parked against the dock bumpers.</li> <li>3. Always park the dock equipment after use (ensure that the lip is safely parked in the lip keepers).</li> <li>4. Conduct routine inspections and maintenance. Failure to do so could cause equipment damage and or personal injury.</li> <li>5. Always call your authorized service representative or manufacturer immediately if a malfunction occurs.</li> <li>6. Always return the restraint arm to the parked position after use.</li> </ol>	

#### 4.0 LOCKOUT / TAGOUT PROCEDURE AND RULES

In accordance with the rules and regulations of the Occupational Safety and Health Administration (OSHA), all affected employees must be notified that the machine or equipment will be shut down and locked out to perform repair or maintenance work. The work area must be checked to ensure that all personnel have been removed or safely repositioned. The machine or equipment power supply shall be locked in the OFF position or disconnected from the energy source. Blue Giant strongly recommends that only OSHA-approved lockout devices and procedures be utilized.

The energy isolating device must bear a prominent warning tag indicating that work is being done on the equipment and the name of the authorized employee responsible for the lockout. It is mandatory that tagout notices not be susceptible to deterioration or illegibility due to weather conditions or exposure to chemicals and moisture.

**⚠ WARNING**

Always lockout and tagout any power source before performing any work on any electrical devices or electrical controls according to OSHA regulations and approved local electrical codes.

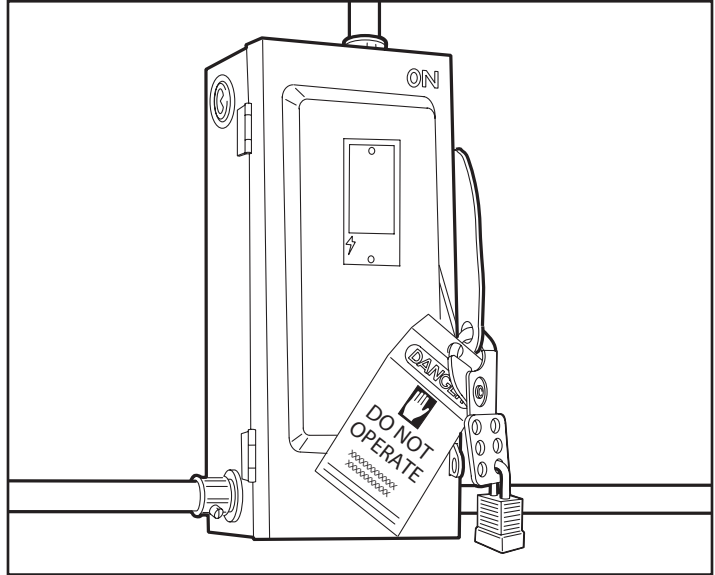

Approved way to lockout / tagout.

#### 5.0 EMERGENCY VEHICLE RESTRAINT LOWERING PROCEDURE

In the event of a power/malfunction failure to the control panel while the restraint arm is in the vertical locked position, the locking mechanism can be released manually. The restraint arm can then be lowered to the stored position. In case of restraint or control panel malfunction, see the "Unlocking the Locking Mechanism" section below.

**NOTE:** Turn-off power switch/disconnect before performing manual emergency procedure. Power may initiate without warning, hence for safe manual lowering, please turn-off switch".

**NOTE:** Confirm that the trailer ICC bar is not applying pressure to the arm / lock mechanism before attempting to unlock: otherwise manual release will not be possible.

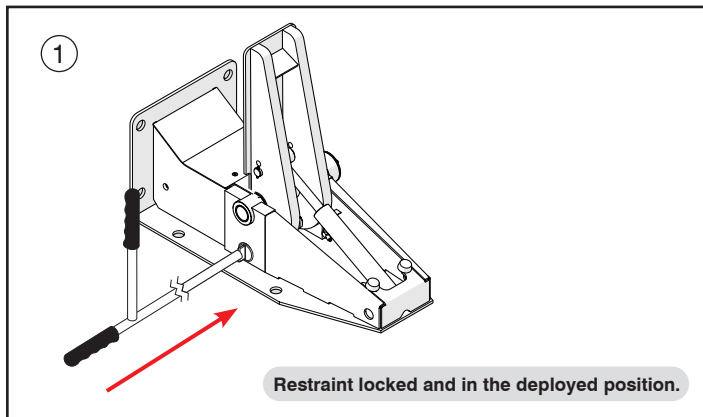

Insert unlocking bar (Part# 54-001682) into slot with pressure for leverage.

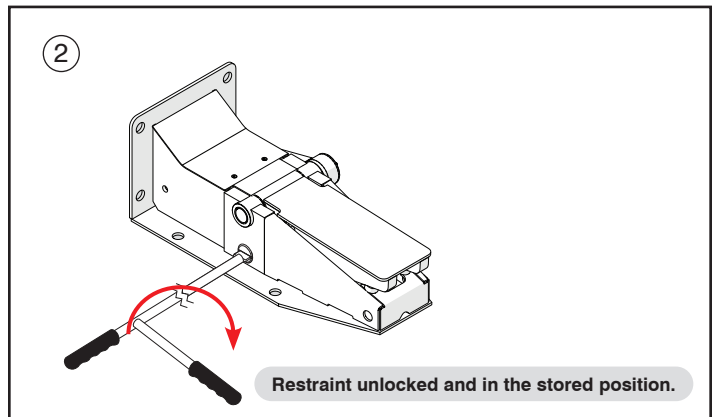

Rotate bar away from the wall to unlock. Restraint arm can descend to the stored position.



## 6.0 CONTROL PANEL OPERATION

Controls combinations of all supported dock equipment: one individual vehicle restraint, one individual dock leveler, and controls for a door. Also equipped with touch buttons, inside forklift operator traffic lights, operator menu screen, and keypad for coded features.

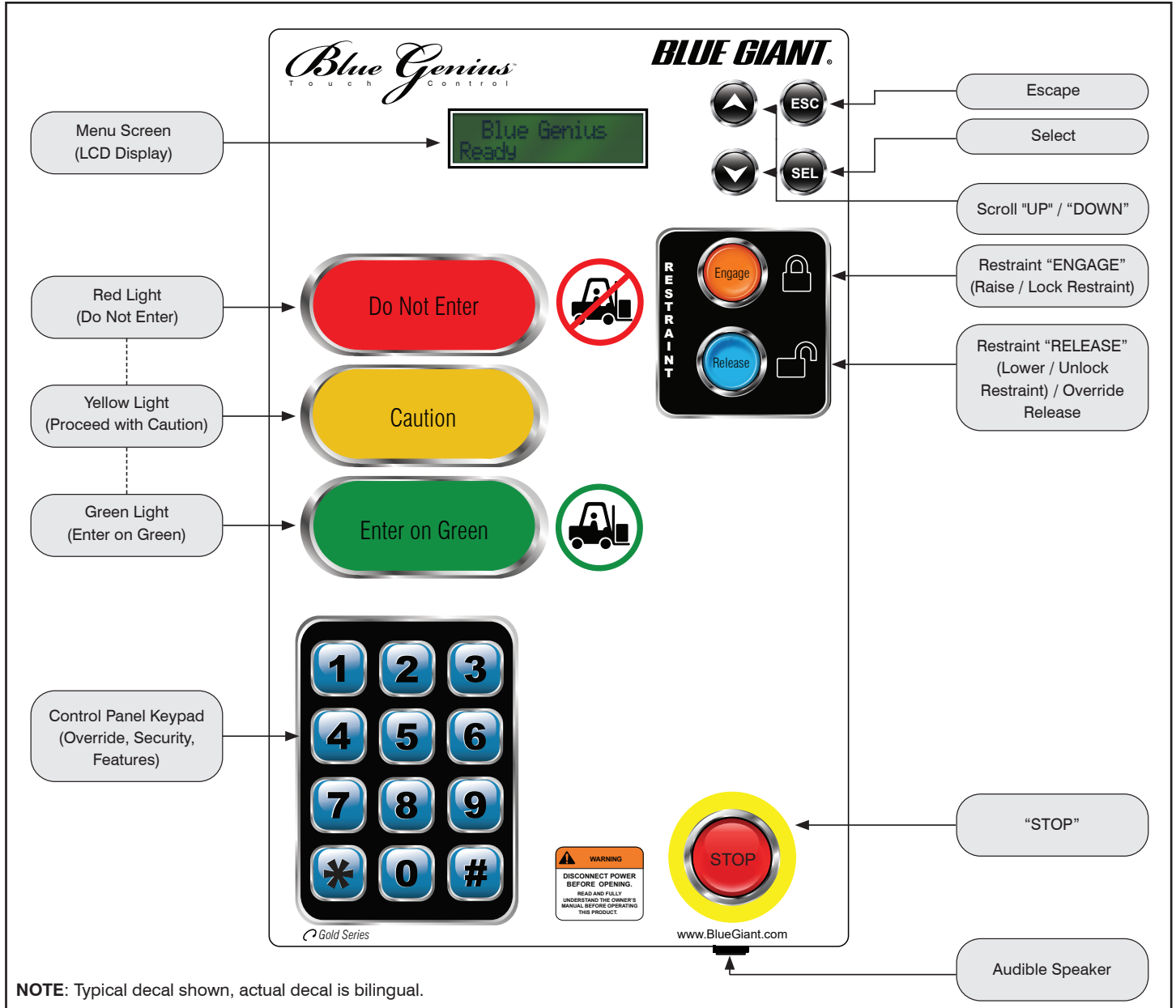

### 6.1 BUTTON FUNCTION

When touching any of the function buttons or keypad, use the pad of the finger. The control panel's unique touch sensors detect the proximity of the dock operator's finger. Audible touch buttons and keypad on the control panel provide instant sound feedback to user input.

The 'Engage' and 'Release' buttons require only a single touch to activate their respective functions. Do not apply constant pressure

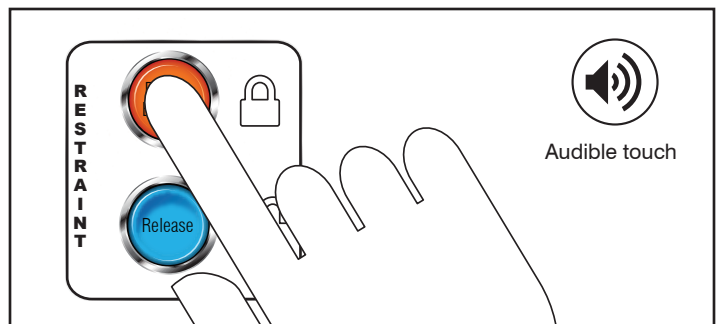

**7.0 OPERATING INSTRUCTIONS**

**WARNING**

Do not operate this vehicle restraint unless you have been trained and authorized to do so, and have read and understood all of the safety information and instructions contained in this manual.

Do not operate this restraint until you have checked its condition. Report the need for repairs to your supervisor immediately and do not operate the unit until repairs are made.

Never try to lift or move any part of the vehicle restraint manually. Keep hands and feet clear of vehicle restraint pinch points.

It is the responsibility of the owner / operator of truck / vehicle to (whenever possible) exhaust the air from air-ride suspension systems prior to performing loading or unloading. Because ICC bars differ in strength and construction, review the need to use wheel chocks in conjunction with the vehicle restraint.

This vehicle restraint is designed for rear impact guards (RIG) and rear impact protection (ICC Bar) that follow the Federal Motor Carrier Safety Administration guidelines (FMCSA section 571.223 and 571.224) + NHTSA (National Highway Traffic Safety Administration) guidelines.

**OPERATING INSTRUCTIONS**  
Only for the StrongArm™ SVR303 Vehicle Restraint

**A ENGAGE RESTRAINT**

- Open the overhead door and visually confirm that the vehicle has a RIG bar and that it is aligned and in range of the restraint arm. The control station light is RED and the traffic light is GREEN.
- Touch the 'Engage' button. The arm will rotate from the home position to secure the RIG bar and the LCD screen will read 'Engaging'. The traffic light will turn RED and the control station light will remain RED. When the RIG bar is secured, the LCD screen will read 'Restraint is Engaged', followed by 'Dock Leveler Restored' and 'Ready to Raise Deck'. After the deck is deployed onto the truck bed, the control station light will turn GREEN.

**B DISENGAGE RESTRAINT**

- After the dock leveler is safely parked, touch the 'Release' button to disengage the vehicle restraint. The control station light will change to RED and the LCD screen will read 'Truck Restraint Releasing'. When the arm reaches the home position, the LCD screen will read 'Blue Genius Ready' and the traffic light will turn GREEN.

**NOTE:** If the restraint arm was not properly parked, the LCD screen will read 'Arm Blocked'. Consult the Troubleshooting section of the manual.

**C VEHICLE RESTRAINT OVERRIDE**

**VISUALLY CHECK TO ENSURE NO RIG BAR IS PRESENT.**

- Touch the 'Engage' button. If a vehicle's RIG bar is absent or cannot be engaged, the LCD screen will read 'RIG Bar Not in Range'. A visual inspection is now necessary to determine whether the vehicle needs to be realigned or if wheel chocks are necessary. The control station light and traffic light are both RED.
- Press the \* key on the keypad. The LCD screen will read 'Enter Code \_\_\_\_'. Enter the supervisor (factory set default code). The LCD screen will read 'Dock Leveler Restored' and then 'Ready to Deploy Deck', followed by 'Restraint is Bypassed'. Once the deck is deployed and home sensor becomes in-active, the control station will turn GREEN while flashing YELLOW. (Note: this code can be changed. Please call your Blue Giant distributor for further information.)
- When work has been completed, store the dock leveler. Then touch the 'Release' button on the control station. The control station's light will turn RED, warning dock staff that the vehicle is no longer accessible. The outside traffic light will turn GREEN, advising the truck driver that it is safe to depart once the wheel chocks are removed.

**THE INSIDE LIGHT WILL CHANGE TO SOLID GREEN WHILE FLASHING YELLOW INDICATING TO PROCEED WITH CAUTION AFTER THE OVERRIDE CODE HAS BEEN ACCEPTED AND DOCK LEVELER HAS BEEN DEPLOYED.**

ENTER OVERRIDE CODE: \*247 (DEFAULT)

**D STOP PROCEDURE**

- Touching the 'STOP' button during operation will cut power to the restraint. If the arm is in mid-travel, it will lower to a hard stop via gravity. To exit the 'STOP' mode touch 'ESC'.

BLUE GIANT www.BlueGiant.com 038-701E Rev.1.1

SVR303 operation placard, provided with equipment—part # 038-701E.

**7.1 FUNCTIONAL DESCRIPTION**

The vehicle restraint is used to restrain a trailer at the loading dock. When engaged, it secures a vehicle's under ride guard (ICC bar), restricting forward movement caused by vehicle creep or unscheduled departure. It is electric-hydraulic operated and monitored via the Blue Genius™ Touch Control Panel, and comes standard with an automatic lights communication package consisting of red/yellow/green control panel lights and exterior red/green LED traffic lights.

EXTERIOR TRAFFIC LIGHT

Exterior red / green traffic lights advise the truck driver when it is safe to depart.

INSIDE COMMUNICATION LIGHTS & CONTROL PANEL

Red / yellow / green control panel lights keep forklift operators and warehouse personnel advised of safety conditions at the loading dock.

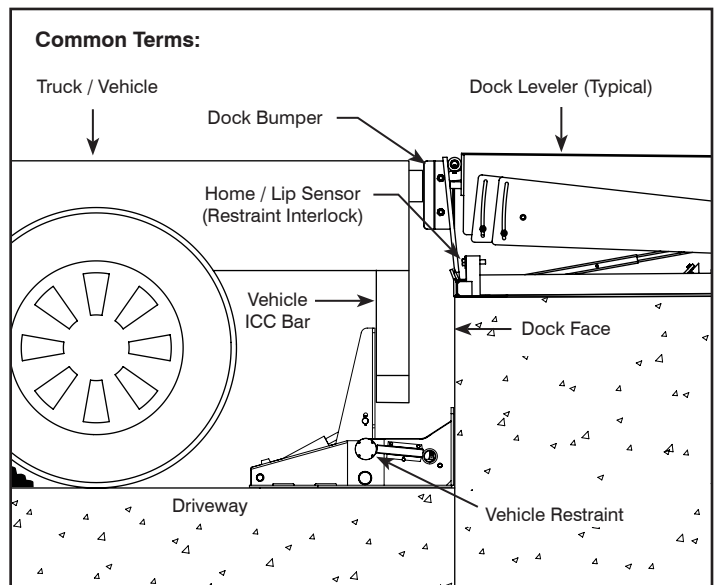

## ADVANCED SAFETY FEATURES

### 7.2 STOP BUTTON FUNCTION

Should an unexpected interference occur or potentially dangerous situation arise, the Blue Genius™ control panel has a temporary 'STOP' button. Touching the 'STOP' button during operation will cause the unit to stop in mid motion and the internal alarm will beep until the stop function is exited. The control panel light will flash RED and the exterior traffic light will be RED. To exit the 'STOP' mode touch the 'ESC' button.

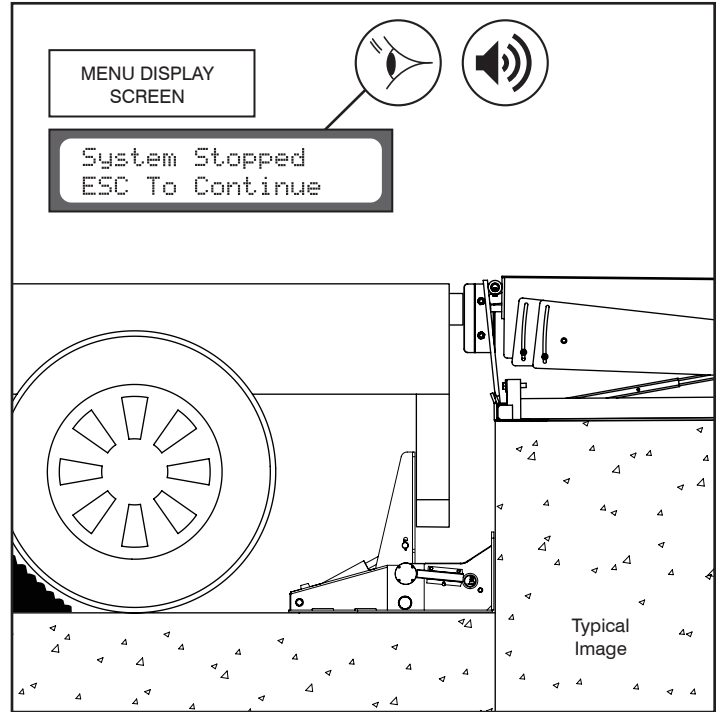
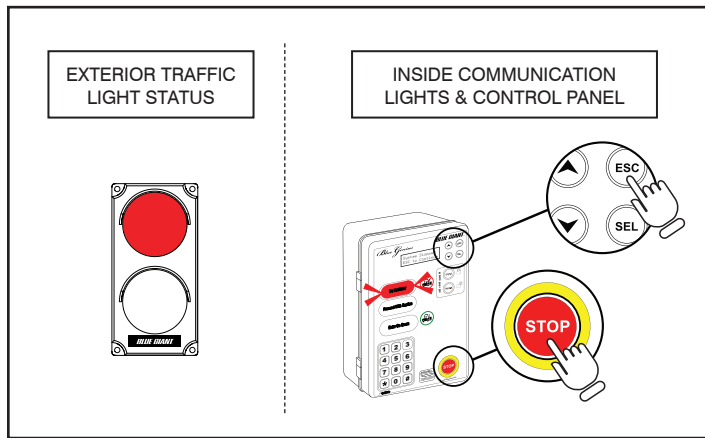

## STANDARD OPERATION PROCEDURES

### 7.3 PRIOR TO USE: EQUIPMENT IN STORED POSITION

The Blue Genius™ control panel is powered on and ready for use. The restraint apparatus is in the home position and the dock leveler lip is parked safely in the lip keepers. The exterior traffic light is GREEN and the control panel light is RED.

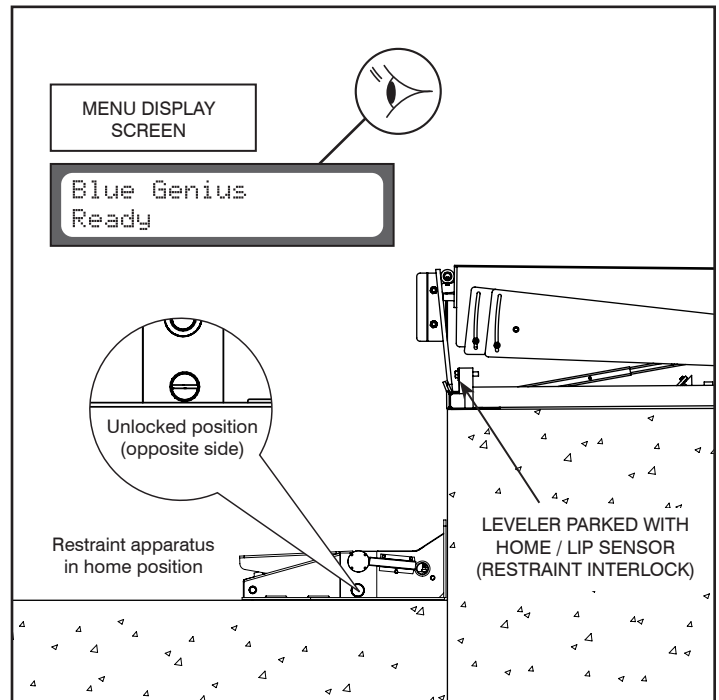
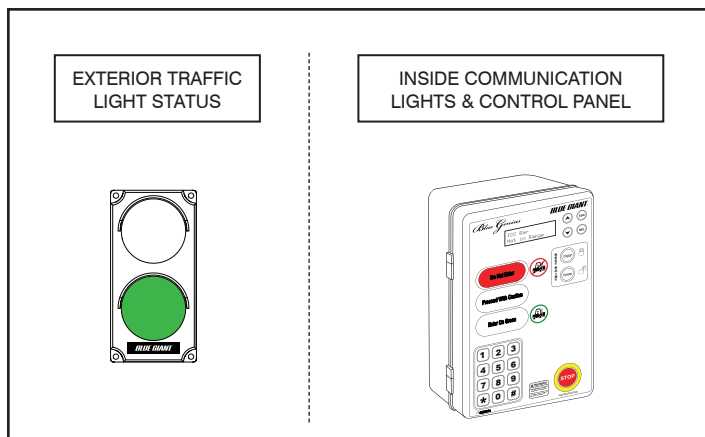

### 7.4 TRAILER AT BAY

The truck reverses into position against the dock leveler bumpers. The exterior traffic light is GREEN and the control panel light is RED.

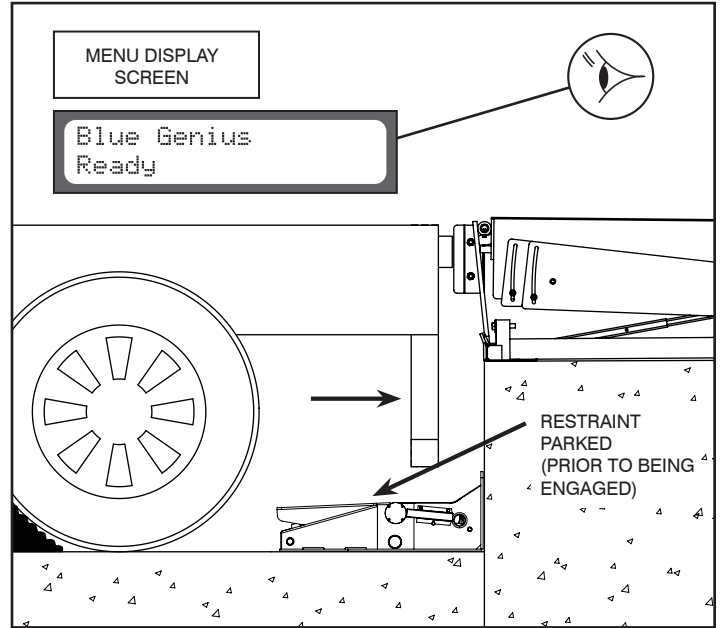
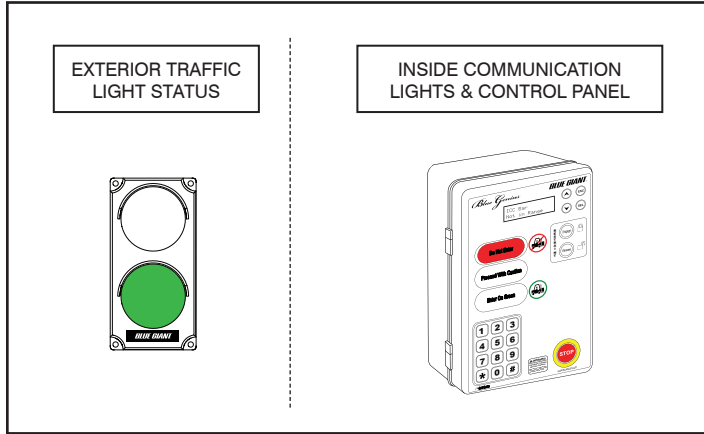

**⚠ WARNING**

The restraint arm is in motion during the engage and release process.  
Please ensure that the personnel and objects remain clear of the motion path when the restraint arm is travelling.

### 7.5 ENGAGING RESTRAINT

Touch the 'Engage' button on the control panel. The securing apparatus will exit the stored position to secure the truck's ICC bar. The LCD screen will read 'Engaging'. The traffic light will turn RED and the control panel light will remain RED. When the ICC bar is secured, the LCD screen will read 'Restraint is Engaged', followed by 'Dock Leveler Restored' and 'Ready to Raise Deck'. The exterior traffic light remains RED, warning the truck driver to stay in place.

**NOTE:** For vehicles without an ICC bar, or if the restraint apparatus cannot successfully engage, please see Section 8.0 "Engaging the Override Feature" for more information.

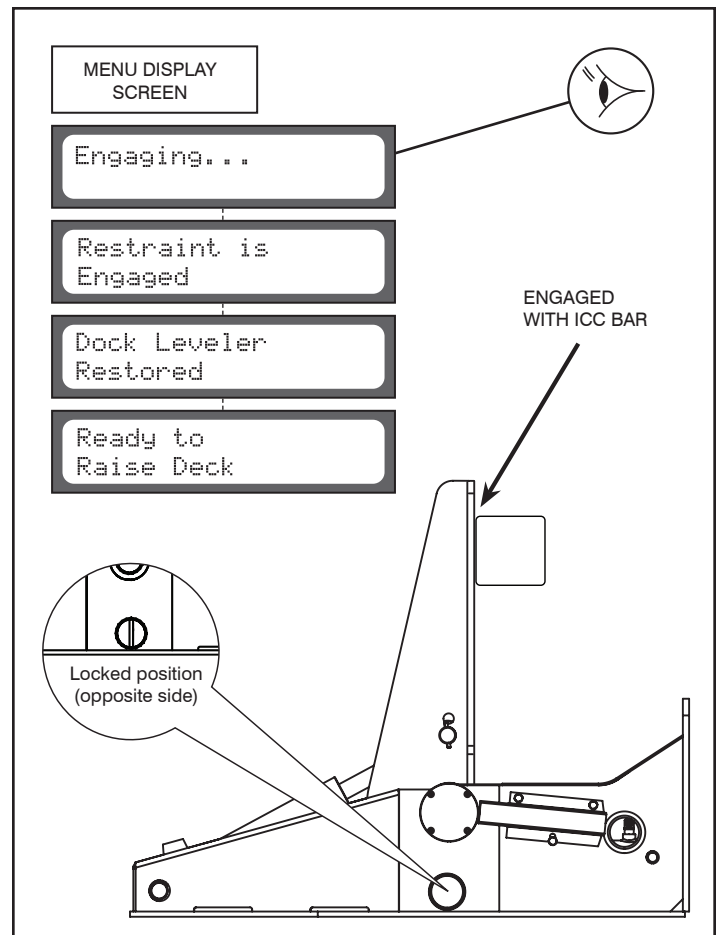
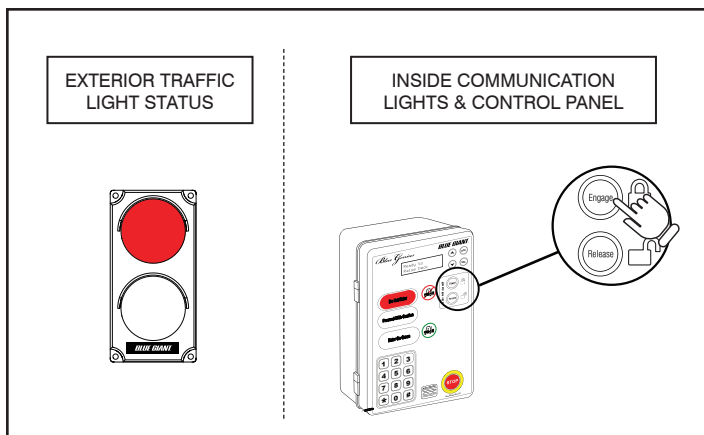

### 7.6 DEPLOYING THE DOCK LEVELER

Deploy the dock leveler (supplied by others) using controls provided by original manufacturer. Both the exterior traffic light and the control panel light will be RED. Touch and hold the 'Deck' button. The LCD screen will read 'Deck Raising'. Keep holding the button until the lip deploys, and then release. The LCD message will change to 'Deck Moving'. The dock leveler and deployed lip will descend onto the truck bed and the message will now read 'Deck Deployed'. The control panel light will turn GREEN.

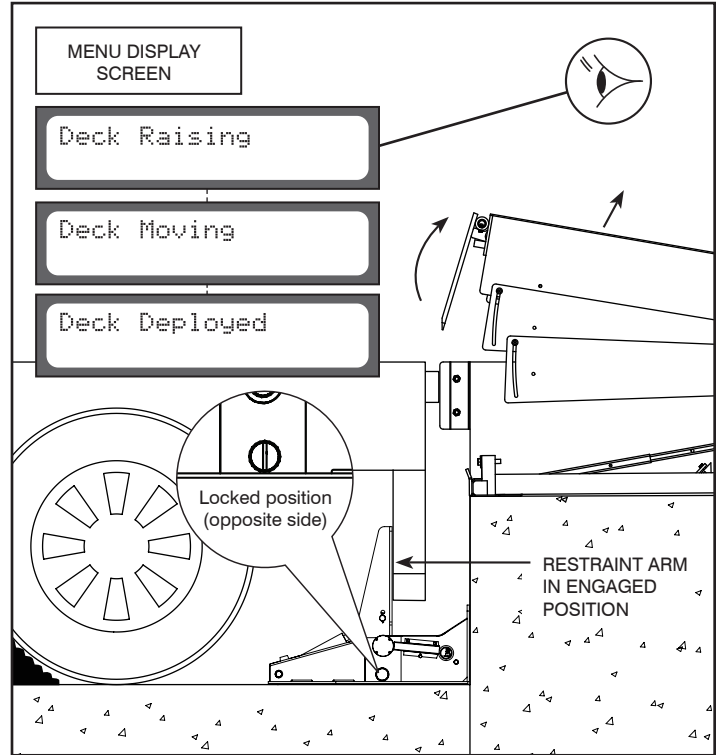
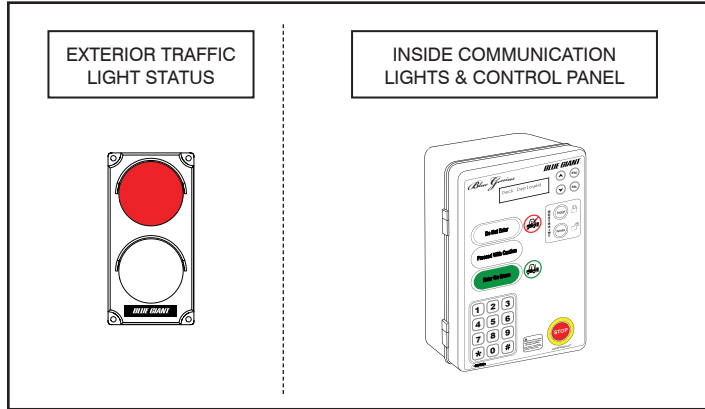

## PERFORM LOADING AND UNLOADING

### 7.7 RELEASING THE RESTRAINT ARM

After the dock leveler is safely parked, the control station light will turn RED while the outside traffic light remains RED. Touch the 'Release' button to disengage the vehicle restraint. The LCD screen will read 'Restraint Releasing.' When the restraint arm reaches the home position, the LCD screen will read 'Blue Genius Ready' and the outside traffic light will turn GREEN.

**NOTE:** If the arm encounters any obstructions while lowering, it will 'pound' down three times to dissolve the blockage. The control panel light will be RED and an alarm will sound. The LCD screen will read 'Arm Blocked- Retrying' followed by 'Restraint Releasing'. After the final unsuccessful attempt, the screen will read 'Restraint Arm Blocked'.

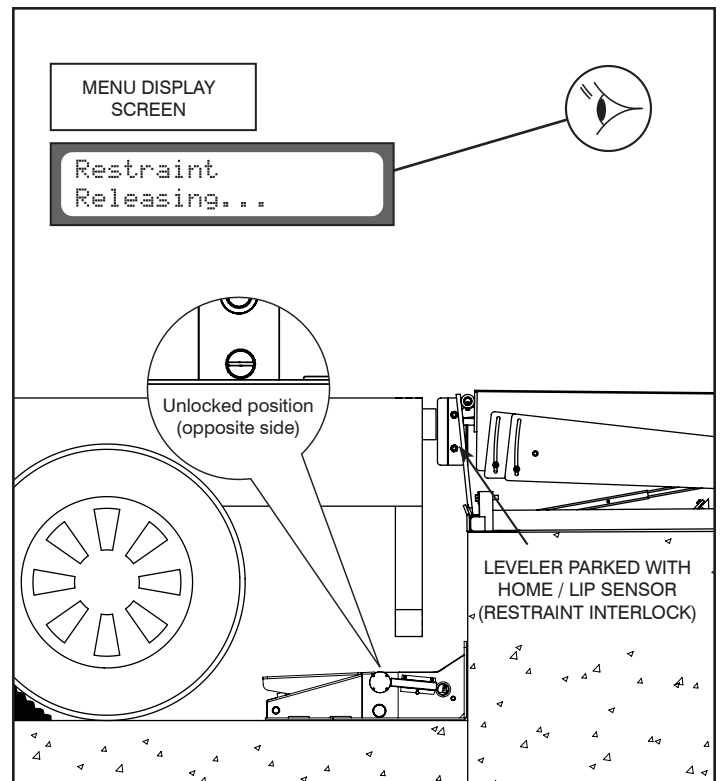
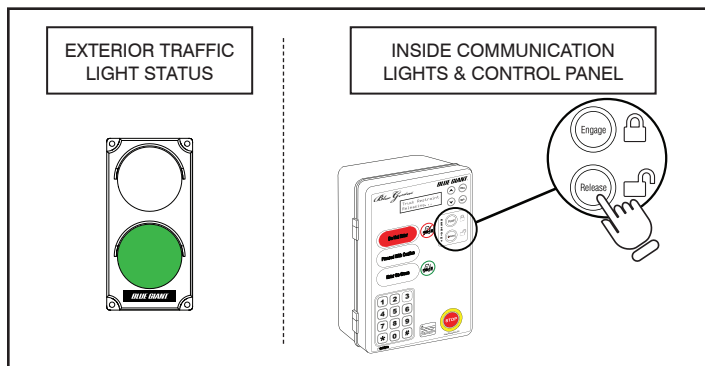

## 8.0 ENGAGING THE OVERRIDE FEATURE

Should it be necessary to bypass the vehicle restraint function (i.e. the truck has an outdated, damaged, or missing ICC bar), a system-approved override code may be entered via the Blue Genius™ touch keypad. This code can be used whether or not the dock leveler is interlocked with the Blue Genius.™ Ensure that the vehicle is manually chocked before loading and unloading begins.

**NOTE:** If a visual inspection confirms that the ICC bar is missing or too damaged to be secured then depending on your Blue Genius Software version:

- Up to Version 3.0 (inclusive), bypass Step 1 in the instructions below and go directly to Step 2, which explains how to enter the Override Code.
  - From Version 3.1 and higher, step 1 is required sequence and then proceed to step 2, follow the instructions. Alternative sequence processes may be available, please consult your Blue Giant representative.
1. During "Engaging Restraint" (Section 7.5), the LCD screen may read "ICC Bar Not in Range." This message indicates that a vehicle's ICC bar is absent or cannot be engaged.

Determine whether the vehicle needs to be realigned or if wheel chocks are necessary.

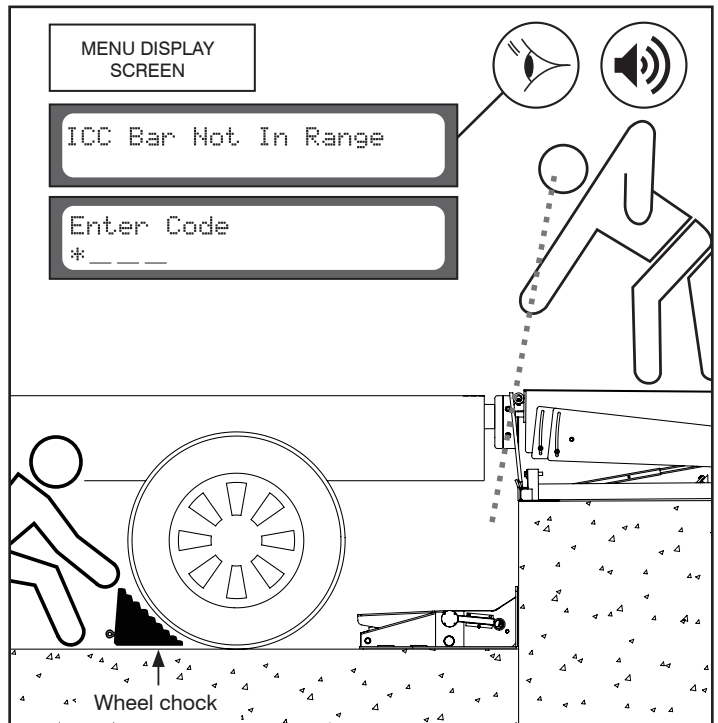

- 2A. Press the \* key on the keypad. The LCD screen will read 'Enter Code \* \_ \_ \_'.

Enter the supervisor code (default factory set code is '247').

**NOTE:** The default code can be changed. Please call your Blue Giant representative for further information.

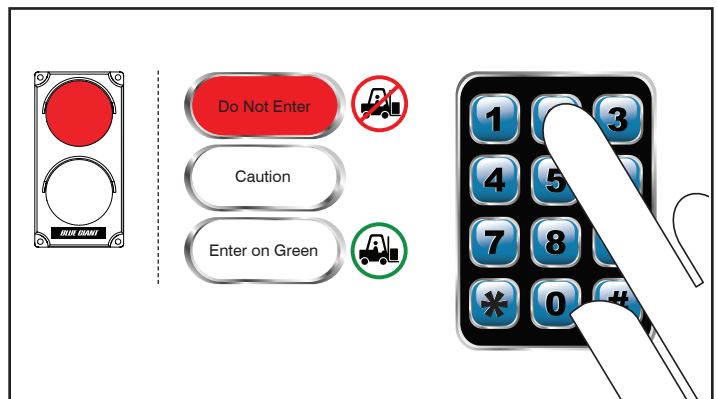

## 8.0 ENGAGING THE OVERRIDE FEATURE CONT'D.

Continue operation of overhead door, dock leveler, and vehicle restraint as outlined in Section 7.5 "Engaging Restraint". The following indicators will appear:

- 2B. The LCD screen will read 'Dock Leveler Restored' and then "Ready to Deploy Deck," followed by "Restraint is Bypassed."

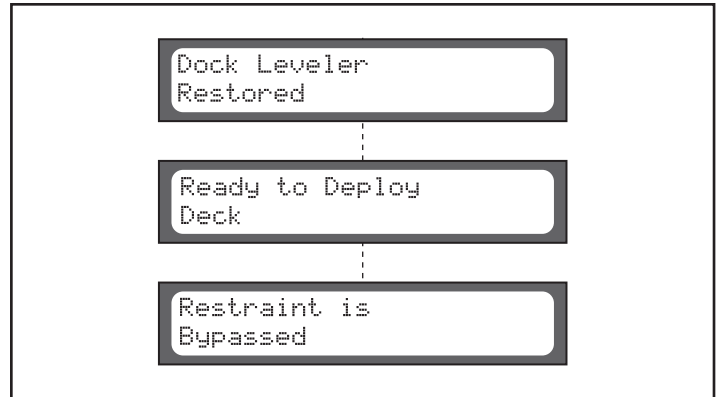

- 2C. Once the deck is deployed and the home/lip sensor becomes inactive, the control panel light will turn GREEN while flashing YELLOW. This indicates that the vehicle restraint is not engaged.

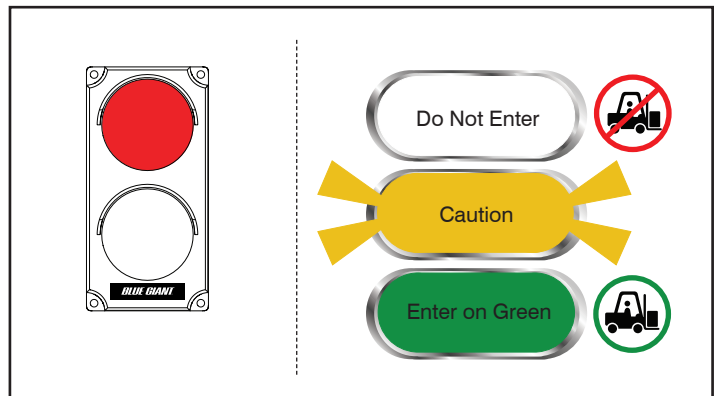

## 8.1 RELEASING THE OVERRIDE FEATURE

1. Store the dock leveler. (**NOTE:** Override is still active when dock leveler and vehicle restraint are in the parked position). The control panel light will turn RED.

Touch the 'Release' button on the control panel to release the override. The control panel will verify that the vehicle restraint has been lowered to the home position. The LCD screen will read "Blue Genius Ready."

The exterior traffic light will turn GREEN, advising the truck driver that it is safe to depart once the wheel chocks are removed.

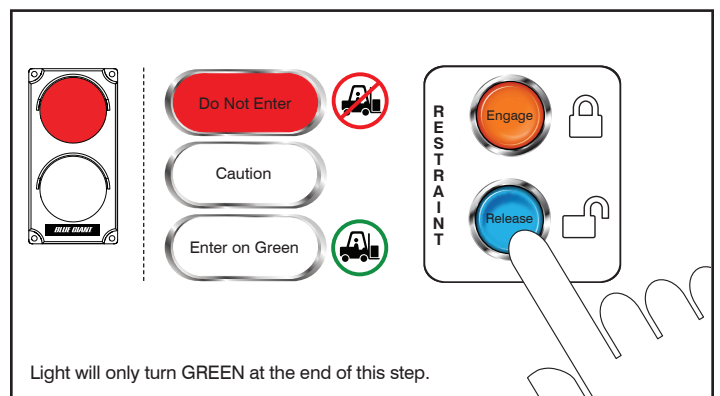

## 9.0 MAINTENANCE



### WARNING

Do not operate and/or service this vehicle restraint until you have read and understood all of the safety information and instructions contained herein and on the vehicle restraint.

Do not work under or around the vehicle restraint without first placing adequate barriers to positively prevent vehicle traffic from entering the work area.

Follow proper lock-out/tag-out procedures.

Keep hands and feet clear of vehicle restraint pinch points and wear appropriate safety attire – glasses, gloves and work boots.

### 9.1 PLANNED MAINTENANCE PROGRAM (PMP)

In addition to the daily operator inspection, the manufacturer recommends (and local government regulations may require) that a planned maintenance program (PMP) and safety inspection program be performed by a trained and authorized service technician on a regular basis to maintain the equipment in safe operating condition. The PMP will provide an opportunity to make a thorough inspection of the safety and operating condition of the dock leveler. Necessary adjustments and repairs can be done during the PMP, which will increase the life of components and reduce unscheduled downtime.

Recommended procedures for a periodic planned maintenance program that covers inspections, operational checks, cleaning, lubrication, and minor adjustments are outlined in this manual.

An authorized dealer or distributor is prepared to assist with a planned maintenance program by offering trained service personnel with expertise in dock leveler maintenance requirements.

### 9.2 OPERATOR DAILY INSPECTION

The vehicle restraint should always be examined by the operator PRIOR TO ANY USE to verify that it is safe to operate.

The manufacturer recommends making multiple photocopies of the PMP Checklist (See Section 9.7 “PMP Checklist - StrongArm™ SVR303 Vehicle Restraint”). The operator should fill out this form to keep a daily record of operation and maintenance issues.

### 9.3 ROUTINE SERVICING AND MAINTENANCE

Regular maintenance and care of the vehicle restraint is very important for cost, operation efficiency, and operator safety. A faulty vehicle restraint is a potential source of danger to the operator, and to other personnel working near it. As with all quality equipment, keep the vehicle restraint in good operating condition by following the recommended schedule of maintenance.

Failure to properly maintain or operate the dock leveler within its rated capacity can void the manufacturer warranty.

### 9.4 PLANNED MAINTENANCE PROGRAM INTERVALS

Arrange for a qualified vehicle restraint service technician to perform regularly scheduled planned maintenance on your vehicle restraint every three months for single shift operations or monthly for multi-shift operations. Call your authorized manufacturer or dealer for further details.

### 9.5 MAINTENANCE SEQUENCE

1. Cleaning, including pit area
2. Visual inspection of all components
3. Lubrication, as required (by a trained service technician only)
4. Test operate all functions
5. Adjustments, if required (by a trained service technician only)
6. Check for missing or damaged dock bumpers
7. Record inspection details and findings for owner's files

### 9.6 RECOMMENDED HYDRAULIC FLUIDS

The unit is shipped with Petro-Canada Hydrex MV22 hydraulic oil unless otherwise optioned.

#### Normal, All Season Weather Conditions:

AW 32 or equivalent.

**NOTE:** Dextron II Automatic Transmission Fluid may be used if other suitable oils are not available.

#### Extreme Low Temperature Conditions:

Esso Univis N15 or Gulf Harmony Arctic 15 or suitable equivalent.

**Biodegradable:** Esso Univis Bio 40 or suitable equivalent.



**9.7 PMP CHECKLIST - STRONGARM™ SVR303 VEHICLE RESTRAINT**

 **DANGER**

When repairing or conducting maintenance procedures on electrical components, perform lockout / tagout steps according to OSHA regulations and approved electrical codes.

 **DANGER**

Prior to installation, place adequate barriers to prevent unauthorized personnel and vehicle traffic from entering the work area.

 **WARNING**

All repairs and maintenance work are to be conducted by trained and authorized personnel ONLY.

**INSPECTED BY:** \_\_\_\_\_ **DATE:** \_\_\_\_\_

**SERIAL #:** \_\_\_\_\_ **DOOR #:** \_\_\_\_\_

Forward this checklist to the person responsible for dock equipment maintenance. See Section 1.1 “Owner’s Purchase Record” for Date in Service.

**INSTRUCTIONS FOR USE:** Indicate “OK for USE” with a check mark ✓ in the appropriate box of each inspection point.

**EVERY DAY:**

- Remove any debris that may have accumulated around the dock equipment
- Check dock bumpers/extensions, wall cracks
- Check interior and exterior lights system
- Check exterior signage
- Check hydraulic hoses for leaks and/or damage
- Check safety warning decals and replace if necessary
- Verify complication-free operation of the Blue Genius™ Control Panel
- Verify complication-free operation of the dock equipment

**EVERY 90 DAYS (30 DAYS FOR MULTI-SHIFT OPERATIONS)**

- Perform all "every day" tasks
- Lubricate SVR303 pivot points
- Check powerpack connections, motor and valves
- Inspect for damaged or missing parts, rust, corrosion, bent parts, cracks, etc.
- Check anchors

**EVERY 90 DAYS CONT'D.**

- Check junction box and control panel for proper and secure mounting. Verify that all electrical connections are firm
- Check hydraulic oil level in powerpack
- Check condition and torque on securing anchors, concrete conditions
- Verify that the proximity sensors are secure

**ONCE A YEAR**

- Drain, flush, and change the hydraulic reservoir as site / oil type dictate

**PHOTOCOPY THIS CHECKLIST AND FILL OUT  
REGULARLY FOR YOUR RECORDS.**

**Explain faults briefly in the space provided below:**

\_\_\_\_\_

\_\_\_\_\_

10.0 RECOMMENDED SPARE PARTS

10.1 STANDARD OPERATIONAL COMPONENTS

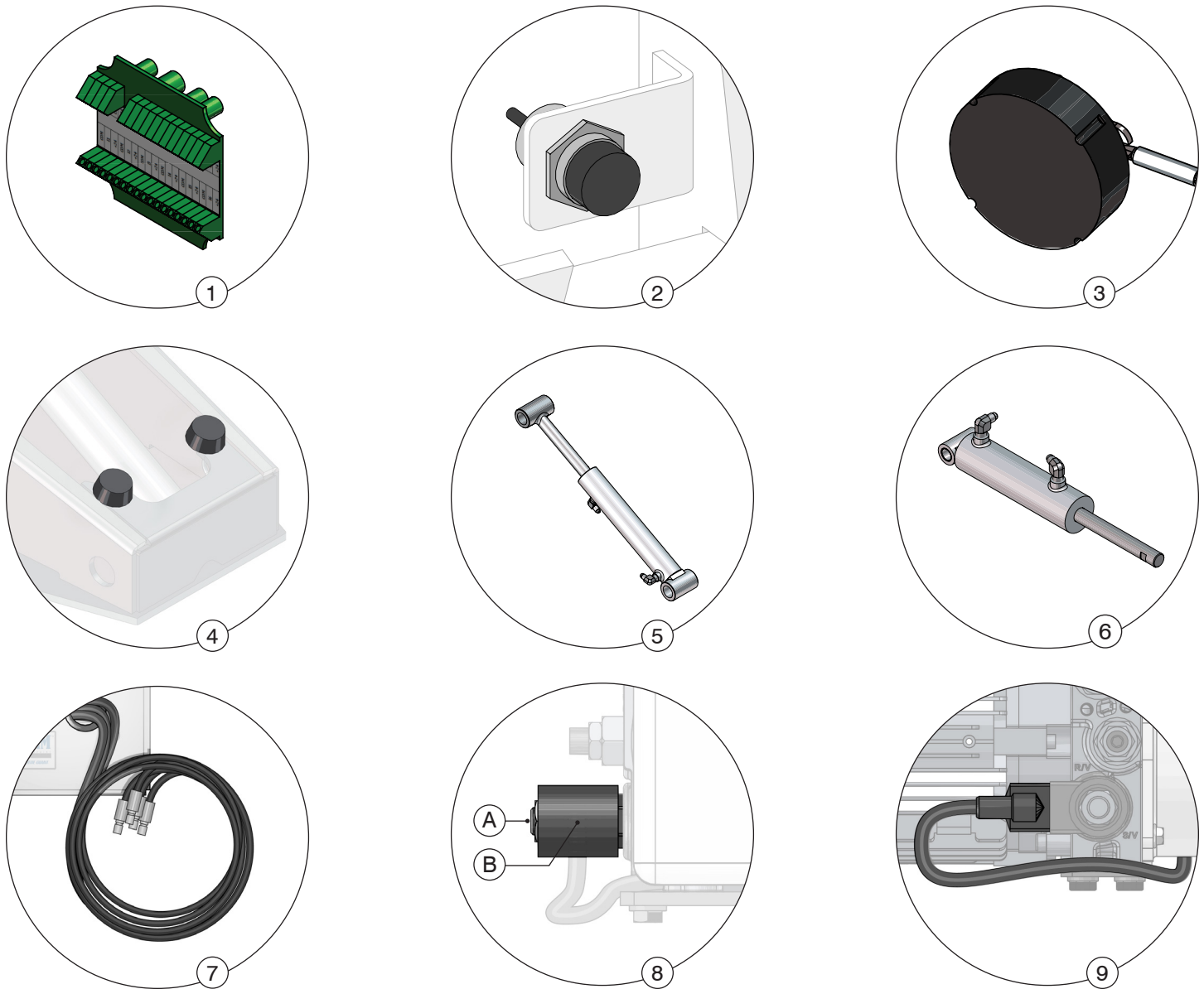

RSP FOR SVR303 – STANDARD OPERATIONAL COMPONENTS			
ITEM	PART NO.	DESCRIPTION	QTY REQ'D
1	026-G025BM	Remote I/O Board (No resistor)	1
2	028-206	Proximity Sensor (30mm Unshield): Home / Lip Sensor with 5m Cable	1
3	54-001563	Position Sensor with Cable	1
4	165-9197	Rubber Bumper	2
5	54-001799	Arm Cylinder with Fittings	1
6	54-00004	Lock Cylinder with Fittings	1

RSP FOR SVR303 – STANDARD OPERATIONAL COMPONENTS				
ITEM	PART NO.	DESCRIPTION		QTY REQ'D
7	Hose #4 High Pressure (TYP. STD. length may change per order requirement)			
	100-5022-3	21' (6.4m)	Lock	Wall Mount STD. 20' hose run
	100-5022-4	23' (7.0m)	Arm	
	100-5022-1	15' (4.6m)	Lock	Pit Mount Option 14' hose run
100-5022-2	17' (5.2m)	Arm		
8	54-012251	A: HYDPP Solenoid Cartridge (411896)		1
		B: Coil (401893)		
9	026-G074	Solenoid Valve Connector with Cable		1

10.2 COMPONENT SHIELDS

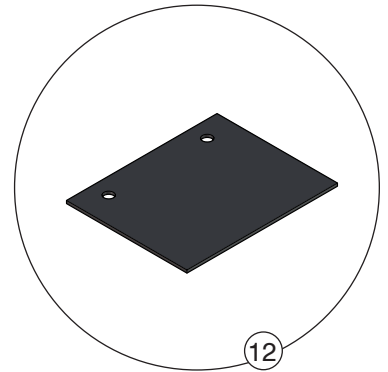
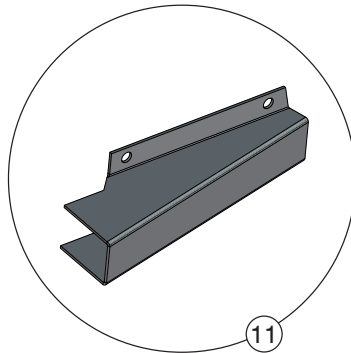
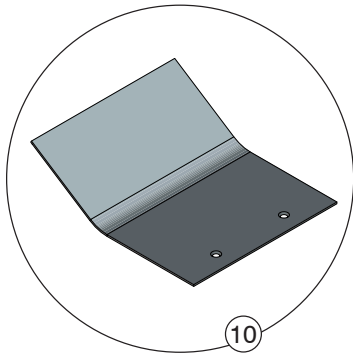

RSP FOR SVR303 – COMPONENT SHIELDS			
ITEM	PART NO.	DESCRIPTION	QTY REQ'D
10	54-010983	Body Cover	1
	54-010983-ZP	Body Cover , Zinc Plated	
11	54-001600	Cable Cover	1
	54-001600-ZP	Cable Cover, Zinc Plated	
12	54-001608	Rubber Seal	1

10.3 OPTIONAL SUPPORT COMPONENTS

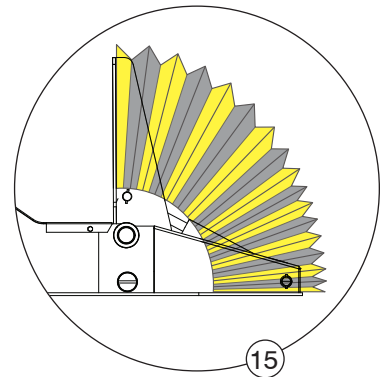
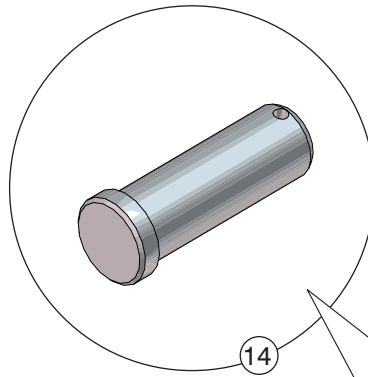
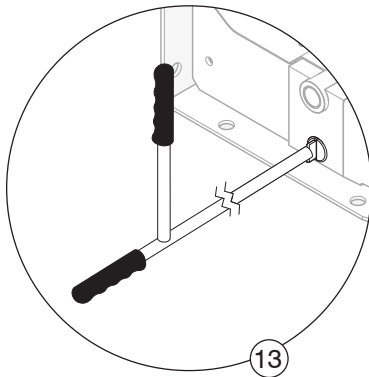

RSP FOR SVR303 – OPTIONAL SUPPORT COMPONENTS			
ITEM	PART NO.	DESCRIPTION	QTY REQ'D
13	54-001682	Lock Manual Release Tool (Long Handle)	1
14	54-00022	Rod End Pin (Lock Cylinder)	1
15	54-001686	Weather / Debris Seal Kit (if previously installed)	1

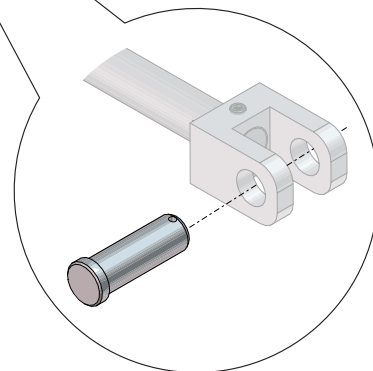

11.0 DECAL IDENTIFICATION AND LOCATION

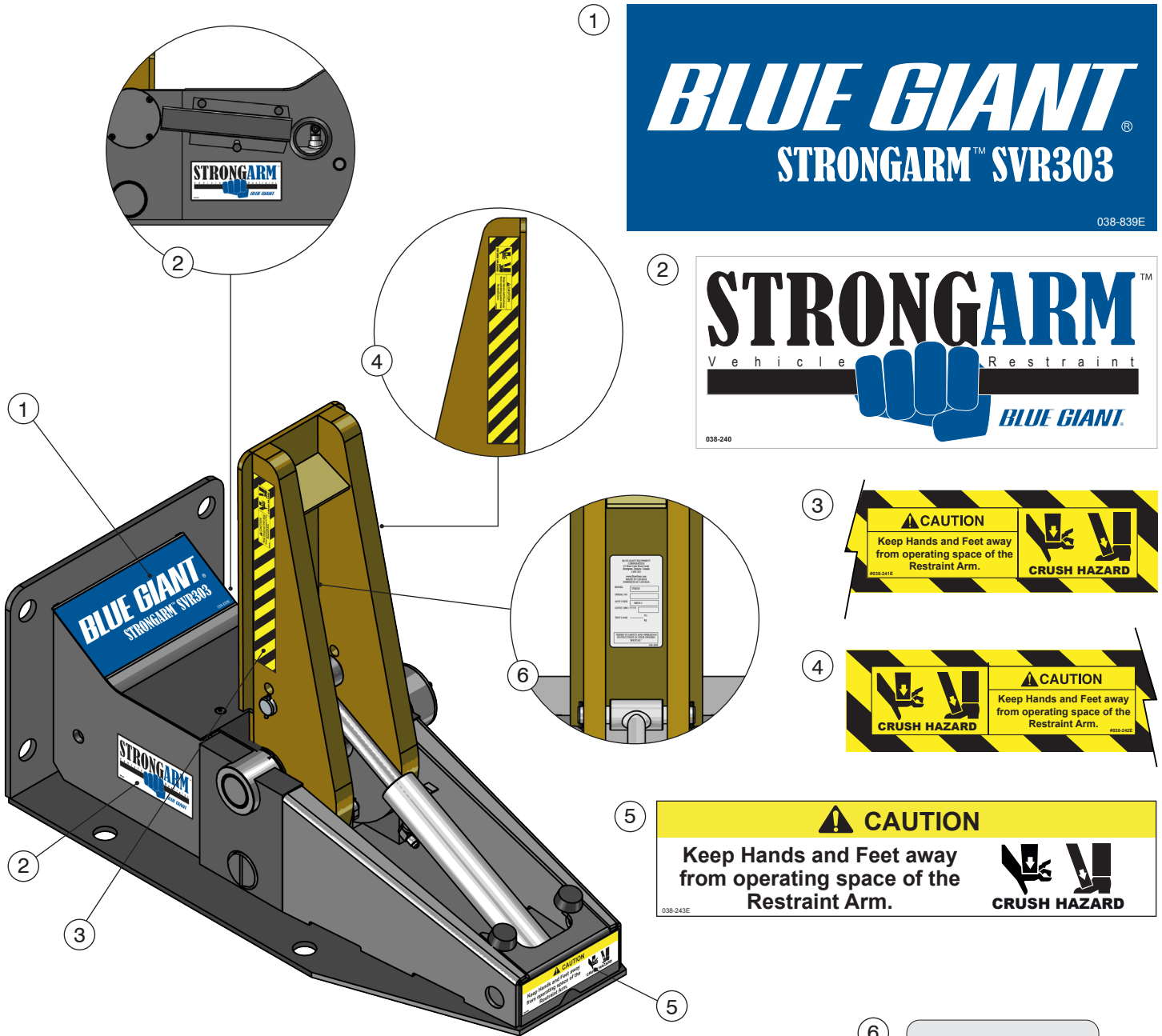

ITEM	QTY	PART NO.	DESCRIPTION
1	1	038-239	Decal - BG SVR303
2	2	038-1187E	Decal - StrongArm™ - Vehicle Restraint
3	1	038-241E	Decal - Crush Hazard - Left Side
4	1	038-242E	Decal - Crush Hazard - Right Side
5	1	038-243E	Decal - Crush Hazard
6	1	038-299E	F Decal - Serial Plate - English / French
			S Decal - Serial Plate - English / Spanish

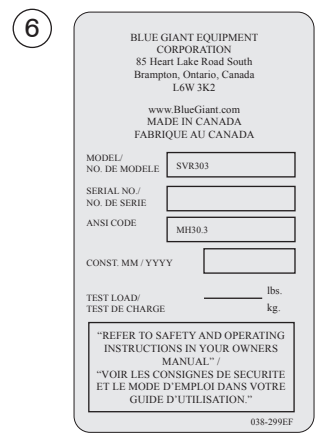

12.0 EQUIPMENT COMPONENT ILLUSTRATIONS

12.1 COMPONENTS AS SHIPPED CHECK LIST

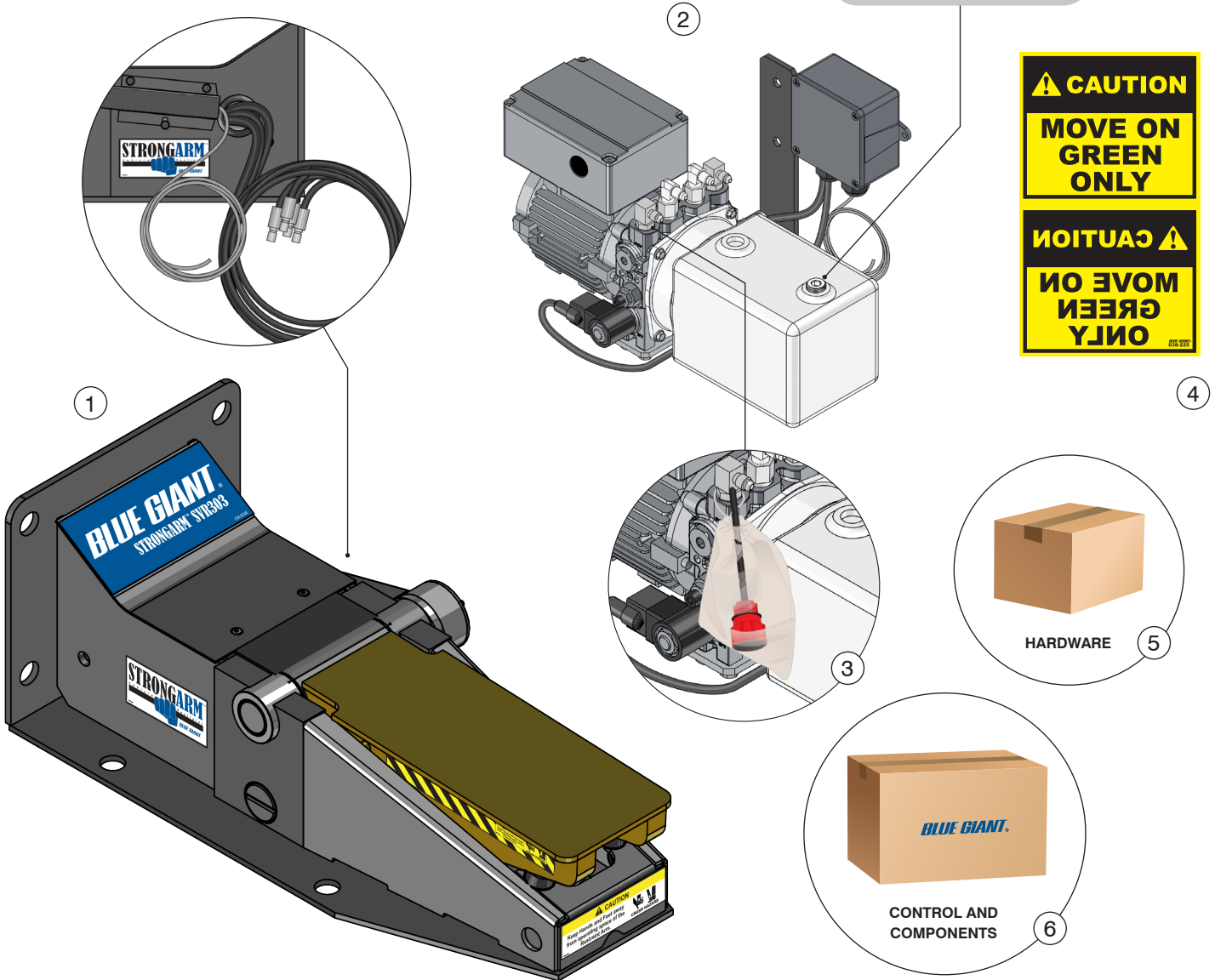

✓	ITEM	QTY	PART NO.	DESCRIPTION	APPROX. WEIGHT		
	1	1	54-010980	SVR303 Body	255 lb	116 kg	
			54-010980-ZP	SVR303 Body, Zinc Plated			
	2	1	54-011700__	Powerpack (See Section 12.5 for Voltages)	34 lb	15 kg	
	3	1	412601	Breather Cap with Dipstick	< .5 lb	< .22 kg	
	4	1	038-225	E	Exterior Driver Warning Sign (English / French / Spanish)	0.7 lb	0.32 kg
				F			
				S			

ITEM # 5 - HARDWARE INCLUDED:

✓	QTY	PART NO.	DESCRIPTION	APPROX. WEIGHT	
	4	010-213	3/4" x 7" Expansion Anchors KB3	.15 lb	.06 kg

ITEM # 6 - CONTROL AND COMPONENTS INCLUDED:

✓	QTY	PART NO.	DESCRIPTION	APPROX. WEIGHT	
	1	BGG0S_F	Complete Control Assembly English / French	6.2 lb	2.81 kg
		BGG0S_S			
	1	038-761E	Operation Placard	—	—
		038-701E	SVR303 Owner's Manual	—	—
	1	032-806	Exterior Traffic Light	1.3 lb	0.6 kg
<b>Restraint Interlock:</b>					
	1	028-206	Lip sensor	0.4 lb	0.18 kg
	1	21-002154	Mounting Bracket		

12.2 MECHANICAL ASSEMBLY - 54-010980 AND 54-010980-ZP

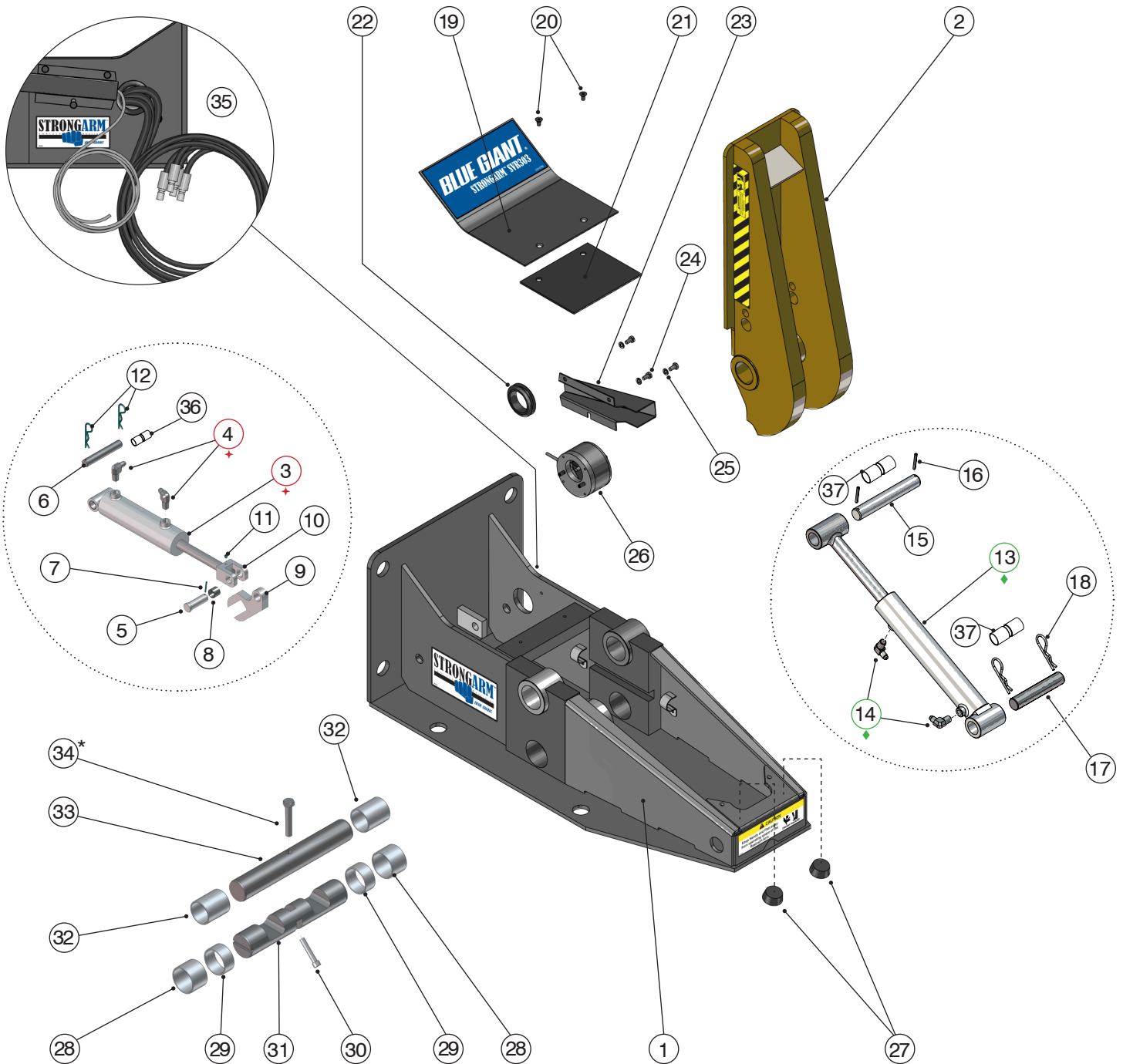

NOTE	PART NO.	DESCRIPTION
★	54-00004	Lock cylinder assembly includes parts highlighted
◆	54-001799	Arm cylinder assembly includes parts highlighted

**12.2 MECHANICAL ASSEMBLY - 54-010980 AND 54-010980-ZP CONT'D.**

ITEM	QTY.	PART NO.	DESCRIPTION
1	1	54-010979	Chassis Weldment
		54-010979-ZP	Chassis Weldment, Zinc Plated
2	1	54-011050	Arm Weldment
3	1	54-00004	Lock Cylinder (Part No. 54-00007-K)
4	2		Fitting (Part No. 034-619)
5	1	54-00022	Rod End Pin
6	1	54-000513	Lock Clevis Pin
7	1	013-020	Spring Pin 1/8 Dia. x 1"
8	1	018-638-1	Plastic Bushing 5/8" x 5/8" L
9	1	54-00043	Lug
10	1	54-00008	Clevis
11	1	014-013	Allen Set Screw 1/4 x 28 UNF
12	2	013-028	Hairpin Cotter
13	1	54-001799	Arm Cylinder (Part No. 54-001273-K)
14	2		Fitting (Part No. 034-619)
15	1	54-00021	Arm Rod End Pin
16	2	013-127	3/16 Dia. Spring Pin x 1.50
17	1	54-000506	Arm Clevis Pin
18	2	013-029	Hairpin Cotter
19	1	54-010983	Body Cover
		54-010983-ZP	Body Cover , Zinc Plated
20	2	011-037	FHSCS

ITEM	QTY	PART NO.	DESCRIPTION		
21	1	54-001608	Rubber Seal		
22	1	037-090	Rubber Grommet		
23	1	54-001600	Cable Cover		
		54-001600-ZP	Cable Cover, Zinc Plated		
24	3	010-072	Cap Screw 1/4-20 x 1/2 HH		
25	3	012-202	Regular Spring Lock Washers (U.S.)		
26	1	54-011350	Sensor Hub Assembly (See Section 12.4)		
		54-011350-ZP	Sensor Hub Assembly (See Section 12.4), Zinc Plated		
27	2	165-9197	Rubber Bumper		
28	2	018-635-1	Plastic Bushing 2" Dia. x 1-1/2" L		
29	2	018-634-1	Plastic Bushing 2" Dia. x 1" L		
30	1	011-184	Socket Head Cap Screw 3/8 x 24UNF x 2		
31	1	54-000534	Lock Pin		
32	2	018-636-1	Plastic Bushing 1-3/4" Dia. x 2" L		
33	1	54-006851-1	Arm Pivot Pin		
34*	1	010-211	Hex Head Cap Bolt 1/2 -13 UNC x 2 3/4		
35	Not in this assembly. These items are sold separately.				
	<b>Hose #4 High Pressure</b> (TYP. STD. Length may change per application requirement, default application lengths shown below)				
	2	100-5022-3	21' (6.4m)	Lock	Wall Mount STD. 20' hose run
	2	100-5022-4	23' (7.0m)	Arm	
	2	100-5022-1	15' (4.6m)	Lock	Pit Mount Option 14' hose run
	2	100-5022-2	17' (5.2m)	Arm	
36	2	54-00007	IGUS BUSHING GSI-1011-16		
37	4	54-001273	IGUS BUSHING GSI-1618-20		

**12.3 GENERAL DIMENSIONS**

14  $\phi$  1 1/4"  
(31.8mm)

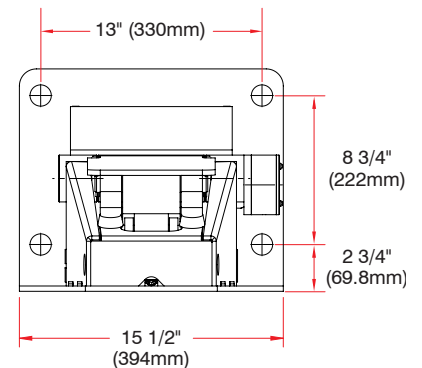
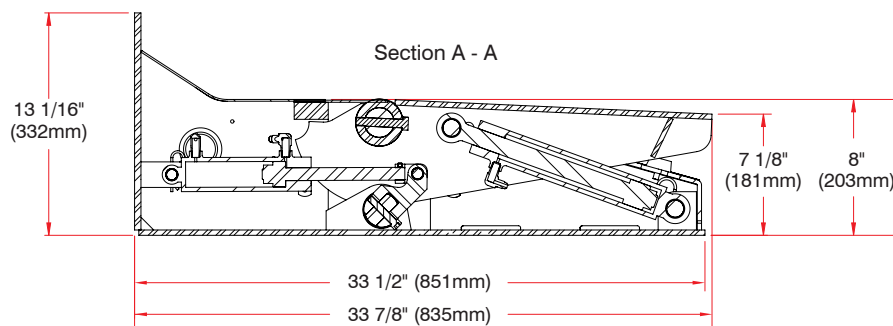
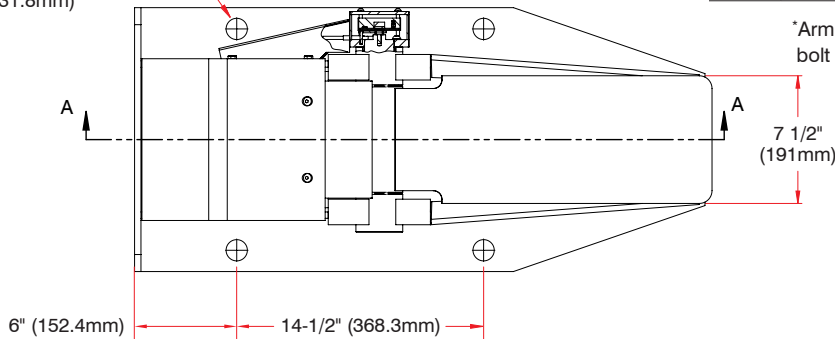

\*Arm cap bolt 010-211 to be installed from the top, ensuring the head of the bolt does not interfere with lock clevis when operating unit.

12.4 RESTRAINT ARM SENSOR ASSEMBLY

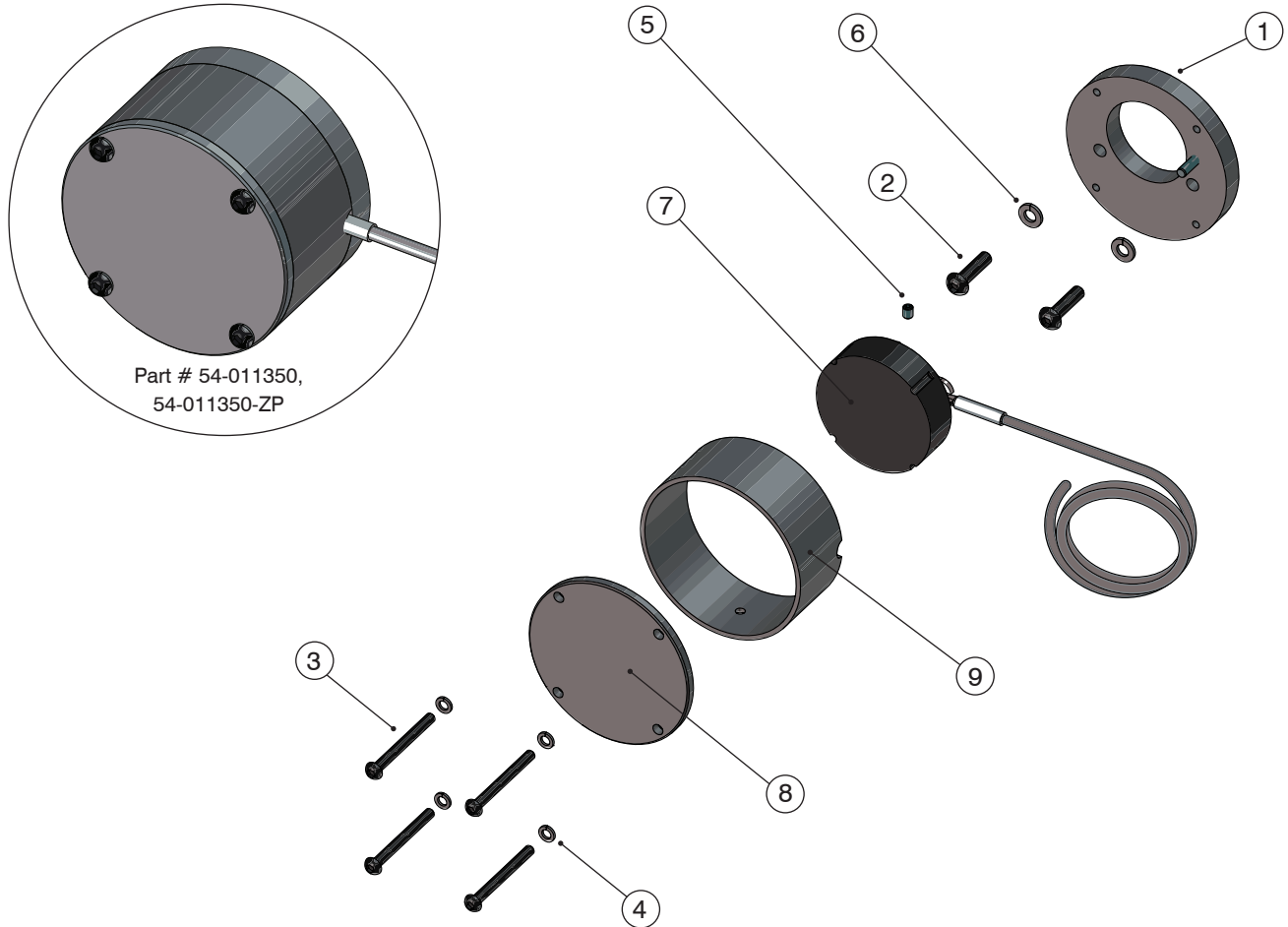

SVR303 RESTRAINT ARM SENSOR ASSEMBLY # 54-011350 AND 54-011350-ZP			
ITEM	QTY	PART NO.	DESCRIPTION
1	1	54-006834-1	Base Plate Assembly
		54-006834-1-ZP	Base Plate Assembly, Zinc Plate
2	2	010-224	Button HD Cap Screw 1/4-20 x 1"
3	4	010-223	Button HD Cap Screw 10-24 x 2" SS
4	4	012-225	Internal Tooth Lock Washer #10
5	1	014-000	Cup Point SSS #10-24 UNC x 1/4 (U.S.)
6	2	012-202	Spring Lock Washer 1/4"
7	1	54-001563	Intelligent Position Sensor (IPS) with Comm Cable
8	1	54-011049	Hub Lid
		54-011049-ZP	Hub Lid, Zinc Plated
9	1	54-011226	Hub Ring
		54-011226-ZP	Hub Ring, Zinc Plated



12.5 POWERPACK PART IDENTIFICATION

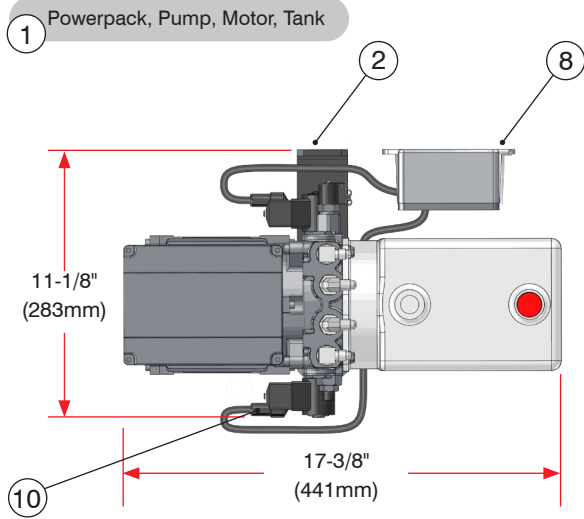

Top View – Wall Mount

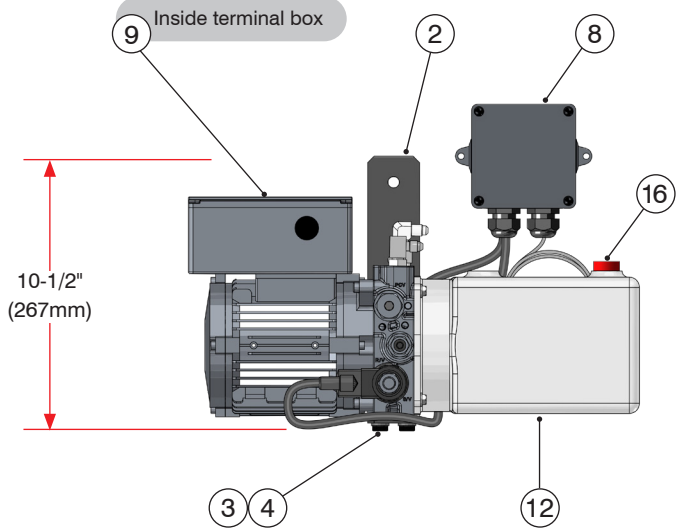

Front View – Wall Mount

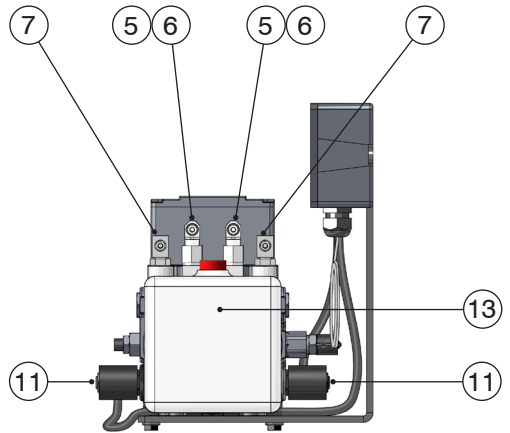

Side View (Tank End) – Wall Mount

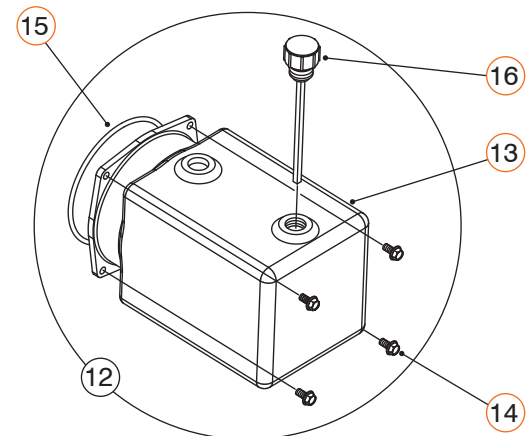

Powerpack Tank Kit

SVR303 POWERPACK - WALL BRACKET ASSEMBLY # 54-011700

ITEM	QTY	PART NO.	DESCRIPTION	ITEM #1
1	1	54-011700-1	SVR303 PP 1PH-115/230V-50/60HZ	033-441-K
		54-011700-2	SVR303 PP 3PH-230/460V-50/60HZ	033-445-K
		54-011700-3	SVR303 PP 3PH-575V-60HZ	033-447-K
2	1	54-011699	Wall Bracket - SVR303 Powerpack	
3	4	010-188	Hex Head Socket 1/2 NPT Cap Screws (Metric)	
4	4	012-201	Lock Washers 3/8" Helical	
5	2	034-580	3/8 Male O-Ring to Female Pipe	
6	2	034-619	Fitting (4MJ - 4MP - 90)	
7	2	034-769	Fitting (6MB - 4MJ - 90)	
8	1	026-H24	Junction Box Assembly (See Section 12.7)	
9	1	025-172	Terminal Blocks 0.32" x 11	
10	2	026-G074	Solenoid Valve Connector with Cable	
11	2	54-012251	Solenoid Cartridge and Coil	
12	1	54-012250	Tank (Reservoir Oil) Kit w/ "O" Ring <b>(NOTE: Hardware includes parts highlighted f)</b>	
f	13	1	412014	Tank
f	14	4	400740	Tank Bolt
f	15	1	401009	"O" Ring for Tank
f	16	1	401504	Breather Cap with Dipstick

12.6 CONTROLS

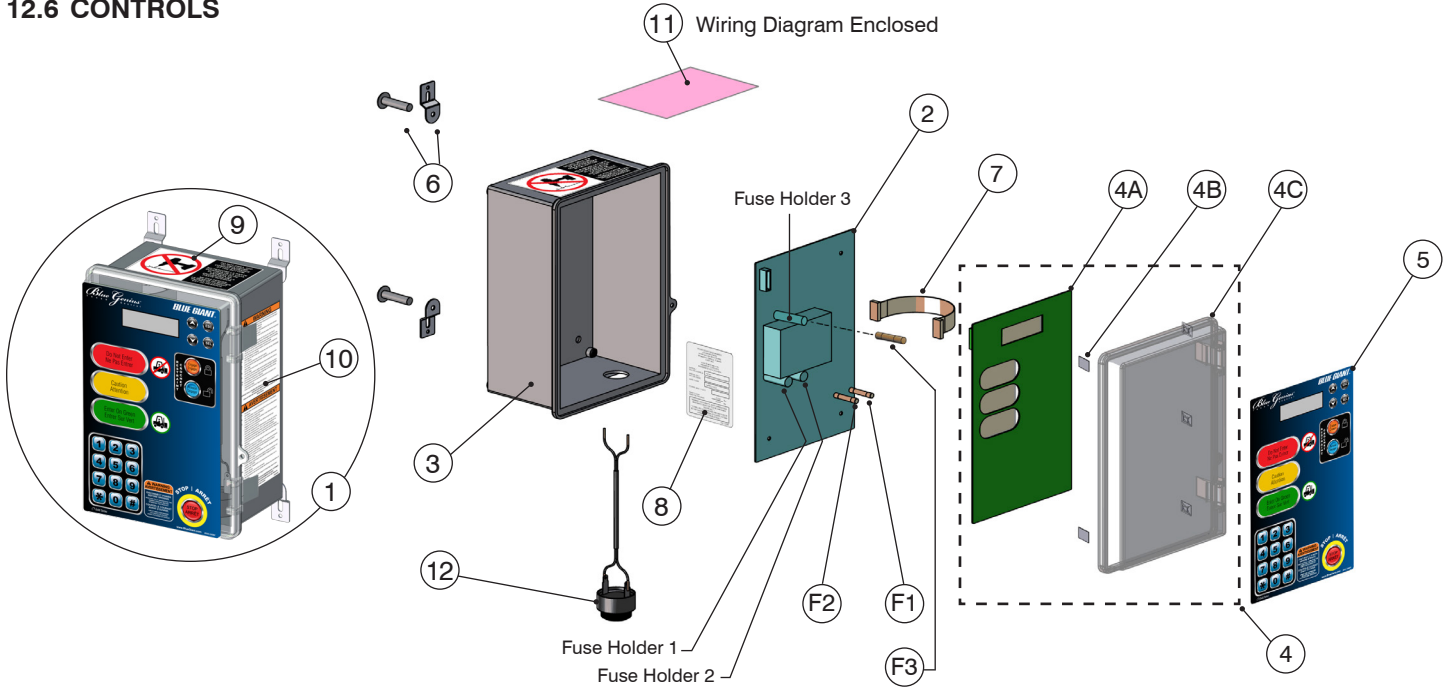

COMPLETE CONTROL STATION ASSEMBLY - ITEM 1 (Example BGG0S1115F)							
ITEM	SINGLE PHASE						
	◇	FUSE	QTY	PART NO.	DESCRIPTION	ASSY PART # *	
2	F1	A	1	026-PB1115	Power Board Sub-Assembly † (1PH 115V 50-60HZ)	BGG0S1115	
	F2	E	1			S	
	F1	C	1	026-PB1230	Power Board Sub-Assembly † (1PH 230V 50-60HZ)	BGG0S1230	
	F2		1			S	
	THREE PHASE						
		◇	FUSE	QTY	PART NO.	DESCRIPTION	ASSY PART # *
2	F1	C	1	026-PB3230	Power Board Sub-Assembly † (3PH 230V 50-60HZ)	BGG0S3230	
	F2		1			S	
	F1	F	1	026-PB3400	Power Board Sub-Assembly † (3PH 400V 50-60HZ)	BGG0S3400	
	F2		1			S	
	F1	G	1	026-PB3460	Power Board Sub-Assembly † (3PH 460V 50-60HZ)	BGG0S3460	
	F2		1			S	
F1	H	1	026-PB3575	Power Board Sub-Assembly † (3PH 575V 60HZ)	BGG0S3575		
F2		1			S		
3			1	025-G010-M	Control Box Enclosure (Includes 4C)		
4			1	025-G014-V3-M	Transparent Cover Door (4C) and Touch Control Board (4A) (Serial # Required)		
4A			1	026-G021-M	Touch Control Board (Serial # Required)		
4B			5	025-062	Cable Tie Mount		
4C			1	025-G014	Transparent Cover Door		
5			1	038-245E	Face Decal		

\* Language on decal: F = English / French S = English / Spanish

◇ Location on Power Board † Includes Fuses ‡ 115 Volt Control Box Shown

ITEM	QTY	PART NO.	DESCRIPTION
6	1	025-G010-1	Mounting Tabs with Hardware (1 pkg of 4)
7	1	026-G030	Ribbon Cable
8	1	038-284E	Decal, Serial Plate
9	1	038-283EFS	Decal, Do Not Drill
10	1	038-853E	Warning Decal
11	1	026-615-1	Anti-Static Poly Bag (Wiring Diagram Enclosed) (Serial # required for diagram)
12	1	026-G402-B	Audible Speaker
F3	1	026-037-1	Fuse, 2.5A, 700V, Fast-Blow 1/4" Glass

AS PER VOLTAGE - SEE ITEM 1

ITEM	QTY	PART NO.	DESCRIPTION
A	1	026-G100	Fuse, 15A, 250V, Time Delay for 1PH, 110-130V
B	1	026-G101	Fuse, 8A, 250V, Time Delay for 1PH, 208-240V
C	1	026-G102	Fuse, 0.5A, 250V, Time Delay for 1 and 3PH, 208-240V
D	1	026-G103	Fuse, 0.25A, 250V, Time Delay for 1PH, 208-240V
E	1	026-G104	Fuse, 0.75A, 250V, Time Delay for 1PH, 110-130V
F	1	026-G105	Fuse, 500mA, 700V, Fast Acting for 3PH, 380-415V
G	1	026-G106	Fuse, 400mA, 700V, Fast Acting for 3PH, 440-480V
H	1	026-G107	Fuse, 315mA, 700V, Fast Acting for 3PH, 575-600V

### 12.7 JUNCTION BOX W/REMOTE I/O

SVR303 REMOTE I/O HARNESS ASSEMBLY # 026-H24			
ITEM	QTY	PART NO.	DESCRIPTION
1	1	025-G020M	Junction Box 4" x 4" (2 Holes)
2	2	025-174	PG16 Cable Gland
3	2	025-177	PG16 Metal Locknut
4	1	025-179	PG16 Multi-Hole Seal (2 Holes)
5	1	025-175	PG16 Multi-Hole Seal (3 Holes)
6	1	026-G025BM	Remote I/O Board (No Resistor)
7	2	026-G074	Solenoid Valve Connector - 3' (914mm)
8	1	026-H16-1	Communication Cable to Blue Genius™ - 30' (9.14 m)
9	1	54-001563	IPS Sensor
10	1	026-G035-2400	Unshielded Home / Lip Cable - 3 Wire - 20' (6.09 m)

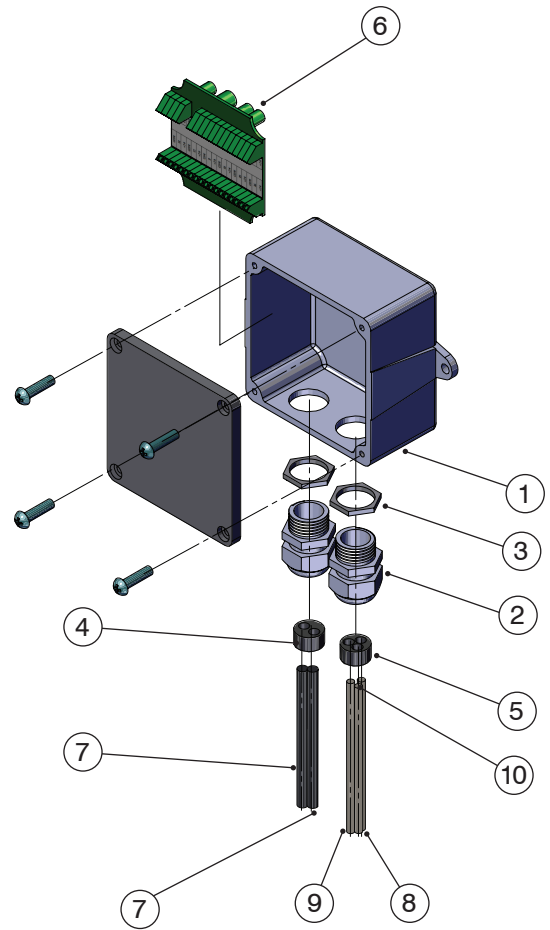

#### 12.7.1 JUNCTION BOX DIMENSIONS

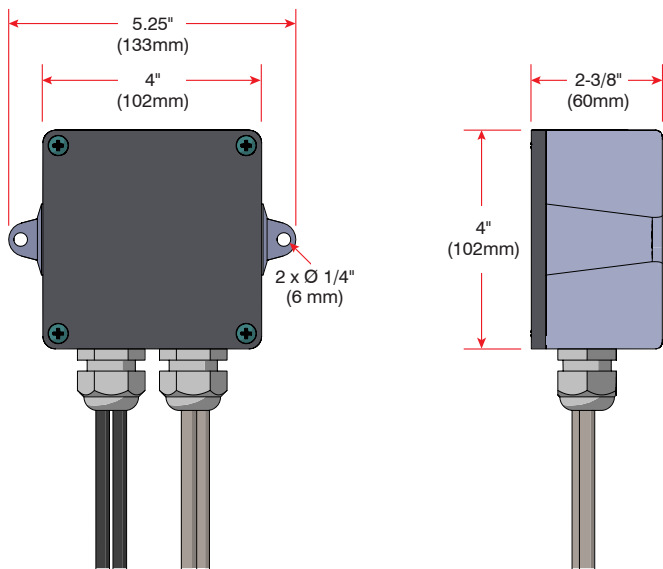

Junction Box - Front View

Junction Box - Side View

### 12.8 RESTRAINT INTERLOCK SENSOR

- Ties sequence of dock leveler to vehicle restraint operation
- Loading dock safety is improved with accurate operation sequence
- Interior traffic light and restraint release operation relies on interlock capability
- Mounted at parked position of any leveler

Alternatively, if dock leveler is not equipped, this function can be tied to overhead door operation sequence. In lieu of the interlock sensor, mount a photo eye at the door closed position.

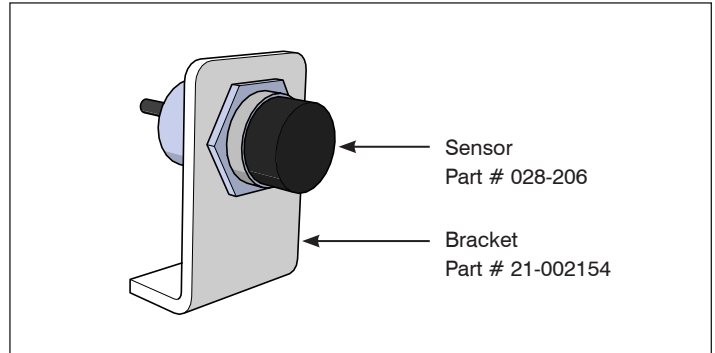

### 12.9 EXTERIOR TRAFFIC LIGHT / MIRROR IMAGE SIGN

The LED traffic lights and mirror image drive warning sign improve loading dock safety.

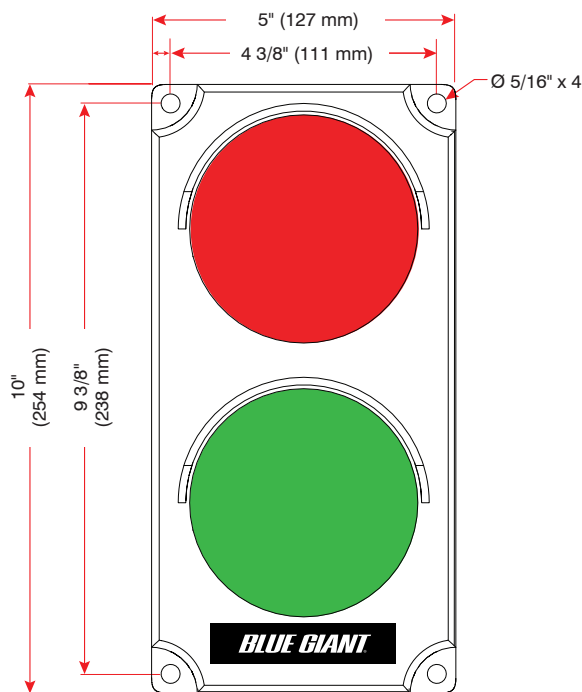

Exterior driver traffic light, part # 032-806.

**NOTE:** Mount to a flat surface. DO NOT deform light housing with irregular wall surface.

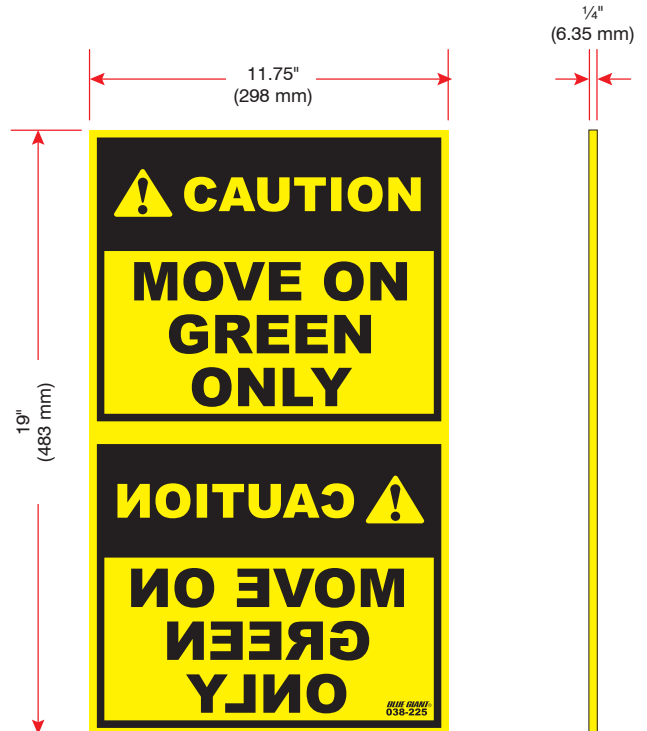

Exterior driver warning sign, part # 038-225.  
(French 038-225F / Spanish 038-225S / Portuguese 038-225P)

13.0 VEHICLE RESTRAINT TROUBLESHOOTING



**WARNING**

Do not attempt to install, make repairs or adjustments. Only a trained and authorized service technician should perform the installation process. Contact your local dealer or distributor for assistance.

PROBLEM	PROBLEM CAUSE
<p>The restraint arm will not rise when the <b>ENGAGE</b> button is touched.</p>	<ol style="list-style-type: none"> <li>1. Faulty wiring, connection or broken wire. Refer to electrical wiring diagram.</li> <li>2. Power source problem. Check incoming voltage and compare to data nameplate voltage.</li> <li>3. Restraint apparatus is seized. Check for foreign objects such as broken wooden pallet splitters.</li> <li>4. The controls are in bypass mode. Press <b>RELEASE</b> button and then <b>ENGAGE</b> button.</li> <li>5. Restraint option not chosen in menu.</li> <li>6. Restraint motor connected to incorrect motor terminal.</li> </ol>
<p>The restraint arm will not lower when the <b>RELEASE</b> button is touched.</p>	<ol style="list-style-type: none"> <li>1. Faulty wiring or connections. Refer to electrical wiring diagram.</li> <li>2. Arm was improperly engaged.</li> <li>3. Restraint apparatus is blocked from coming down. Check for foreign objects.</li> <li>4. Trailer load on restraint arm causing pressure on lock release. Back up trailer.</li> <li>5. The dock leveler deck is not restored to the home position properly.</li> <li>6. Locking mechanism is seizing.</li> </ol>
<p>Restraint is engaged but the inside light is still red.</p>	<ol style="list-style-type: none"> <li>1. Dock leveler not deployed. Restraint interlock sensor still sees lip.</li> </ol>
<p>Restraint works but LED cover lights are not lit. LCD display is working.</p>	<ol style="list-style-type: none"> <li>1. Power source for lights is damaged. Replace control board.</li> </ol>
<p>Exterior traffic lights are dim, displaying incorrectly (wrong color) or malfunctioning (only one light works).</p>	<ol style="list-style-type: none"> <li>1. Check wiring to lights. Ensure that the +24 red exterior light is connected to terminal # 12 on the control terminal strip label 1 to 14 and that the +24 green light is connected to terminal #13 and the common of the lights are connected to terminal #14.</li> <li>2. Lights common wire is terminated in wrong terminal (other than #14).</li> </ol>
<p>The restraint is in the parked position and the inside light is green with yellow light flashing.</p>	<ol style="list-style-type: none"> <li>1. The restraint is in the bypass mode.</li> <li>2. Restraint interlock sensor is not active.</li> </ol>
<p>The restraint is powered on. LCD screen displays the message 'Restraint is Bypassed'. The control panel lights are green and flashing yellow while the exterior traffic light is red.</p>	<ol style="list-style-type: none"> <li>1. The dock leveler is either not parked or the dock's home / lip sensor does not detect it as being in the parked position.</li> </ol>

## 14.0 BLUE GENIUS™ LCD MESSAGES



### WARNING

Do not attempt to install, make repairs or adjustments. Only a trained and authorized service technician should perform the installation process. Contact your local dealer or distributor for assistance.

MESSAGE	EXPLANATION
<p><b>'Fault 31'</b></p> <p>IPS sensor value too low</p>	<ol style="list-style-type: none"> <li>1. IPS shaft not secured by set screw, tighten set screw making sure the IPS green LED light is lit with the restraint arm in its fully lowered position. <b>NOTE:</b> the set screw does not tighten down on the flat of the IPS shaft.</li> <li>2. IPS not programmed. See set-up procedure.</li> <li>3. Home value is not set in range. Consult factory or dealer.</li> </ol>
<p>During self test mode the following message appear: <b>'Remote I/O Bad'</b> <b>'Positioner Bad'</b></p>	<ol style="list-style-type: none"> <li>1. Faulty wiring, communication cable not connected or damaged.</li> <li>2. Blue Genius™ communication chip faulty.</li> </ol>
<p><b>'Please restore Dock Leveler'</b></p>	<ol style="list-style-type: none"> <li>1. Restraint interlock sensor (home/lip) is in-active, out of range.</li> <li>2. Restraint interlock sensor (home/lip) is not connected.</li> <li>3. Faulty wiring.</li> <li>4. Dock not in stored/home position.</li> <li>5. Sensor is faulty, replace.</li> </ol>
<p><b>'ICC Bar not in Range'</b></p>	<ol style="list-style-type: none"> <li>1. Restraint arm went up and did not find ICC bar in preset range.</li> <li>2. IPS not programmed.</li> </ol>
<p><b>'Fault 10'</b> Communication error</p>	<ol style="list-style-type: none"> <li>1. Faulty wiring, check for loose or broken communication cable wire(s).</li> <li>2. Noise interference, check routing of communication from Blue Genius™ controls to remote devices.</li> </ol>
<p><b>'Restraint Arm Blocked'</b> Followed by: <b>'Restore Restraint, press 'SEL' to continue, Blue Genius Warning'</b> (repeats)</p>	<ol style="list-style-type: none"> <li>1. Restraint arm failed to lower all the way down. Check for debris.</li> <li>2. Faulty IPS board.</li> </ol>
<p><b>'Restraint is Engaged'</b> Followed by: <b>'Dock Leveler Restored', 'Ready to Deploy Deck'</b>. (repeats)</p>	<ol style="list-style-type: none"> <li>1. The <b>Engaged</b> button has been touched and vehicle restraint is in locked position.</li> </ol>
<p>During self test mode the following message appears: <b>'Remote I/O Bad'</b></p>	<ol style="list-style-type: none"> <li>1. Faulty wiring, check communication cable wires for loose connections.</li> <li>2. Remote I/O is faulty, replace.</li> <li>3. Blue Genius™ power board is faulty, replace.</li> </ol>
<p>During self test mode the following message appears: <b>'Positioner Bad'</b></p>	<ol style="list-style-type: none"> <li>1. Faulty wiring, check communication cable wires for loose connections.</li> <li>2. IPS board is faulty, replace.</li> <li>3. Blue Genius™ power board is faulty, replace.</li> </ol>

## 15.0 WIRING DIAGRAMS

### NOTICE

The following wiring diagrams are sample configurations only. Wiring diagrams specific to your needs will be provided inside the control panel and/or as part of your submittal package.

15.1 WIRING DIAGRAM—115V SINGLE PHASE

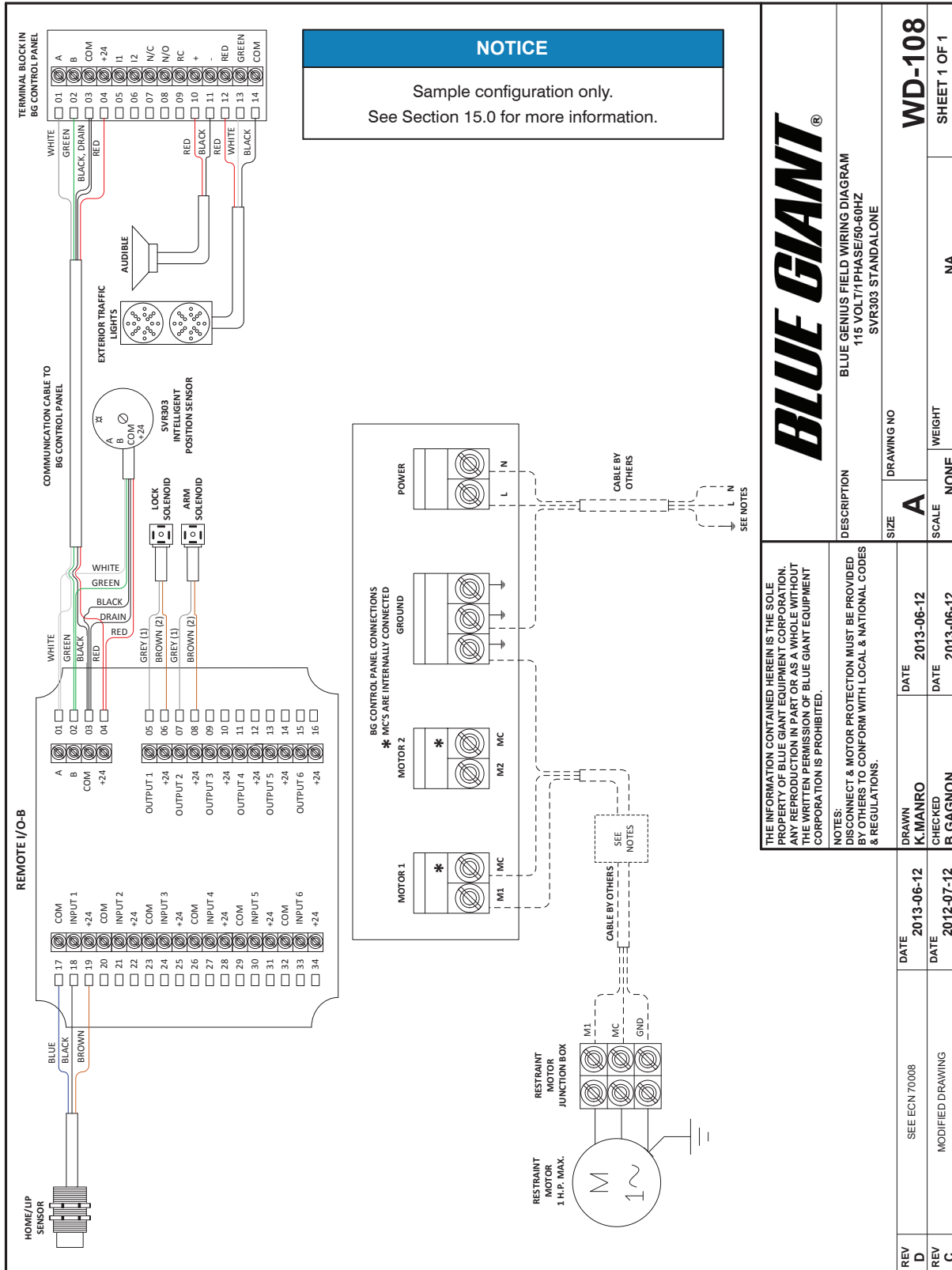

15.2 WIRING DIAGRAM—230V SINGLE PHASE

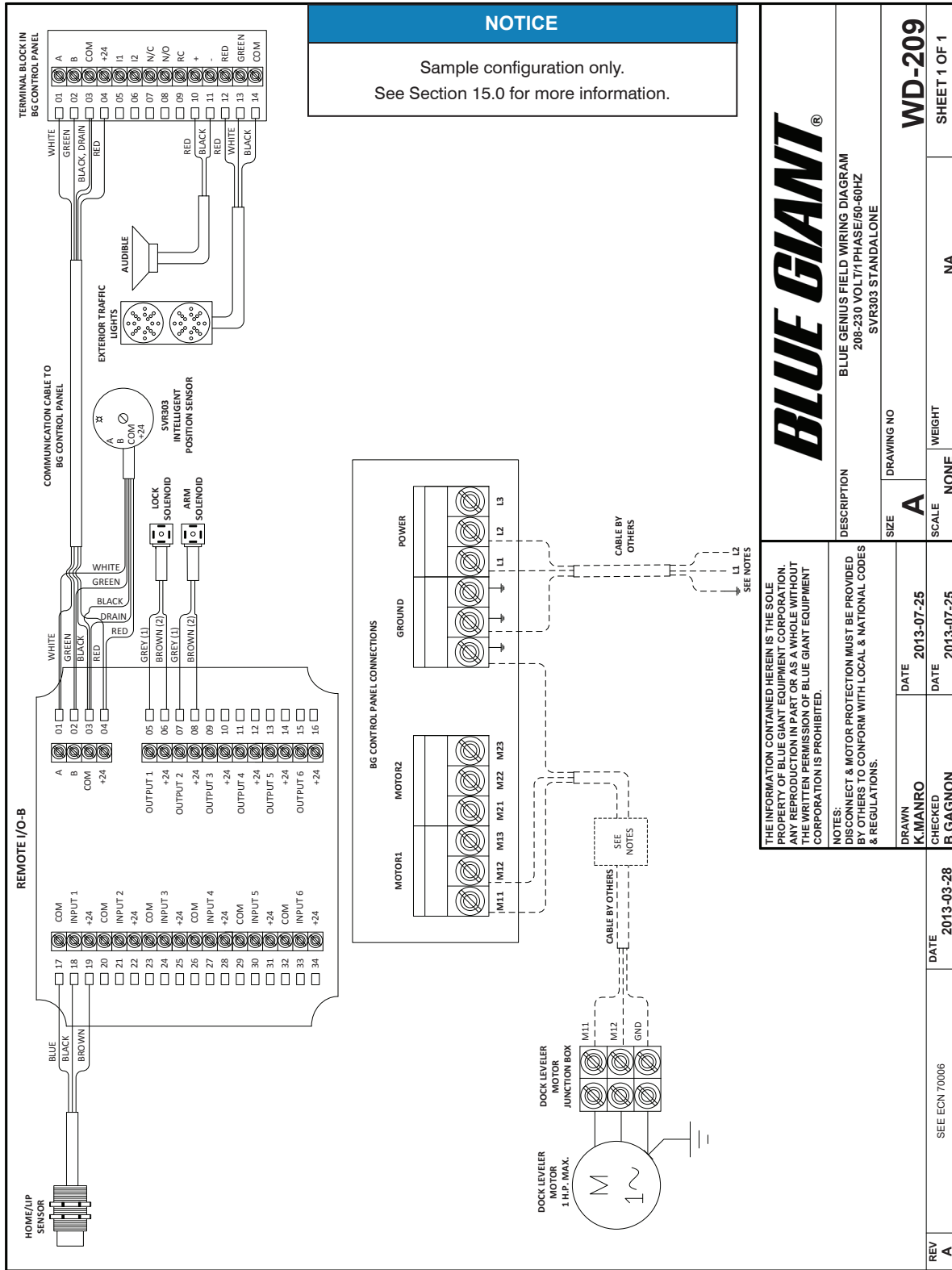



15.3 WIRING DIAGRAM—208-600V THREE PHASE

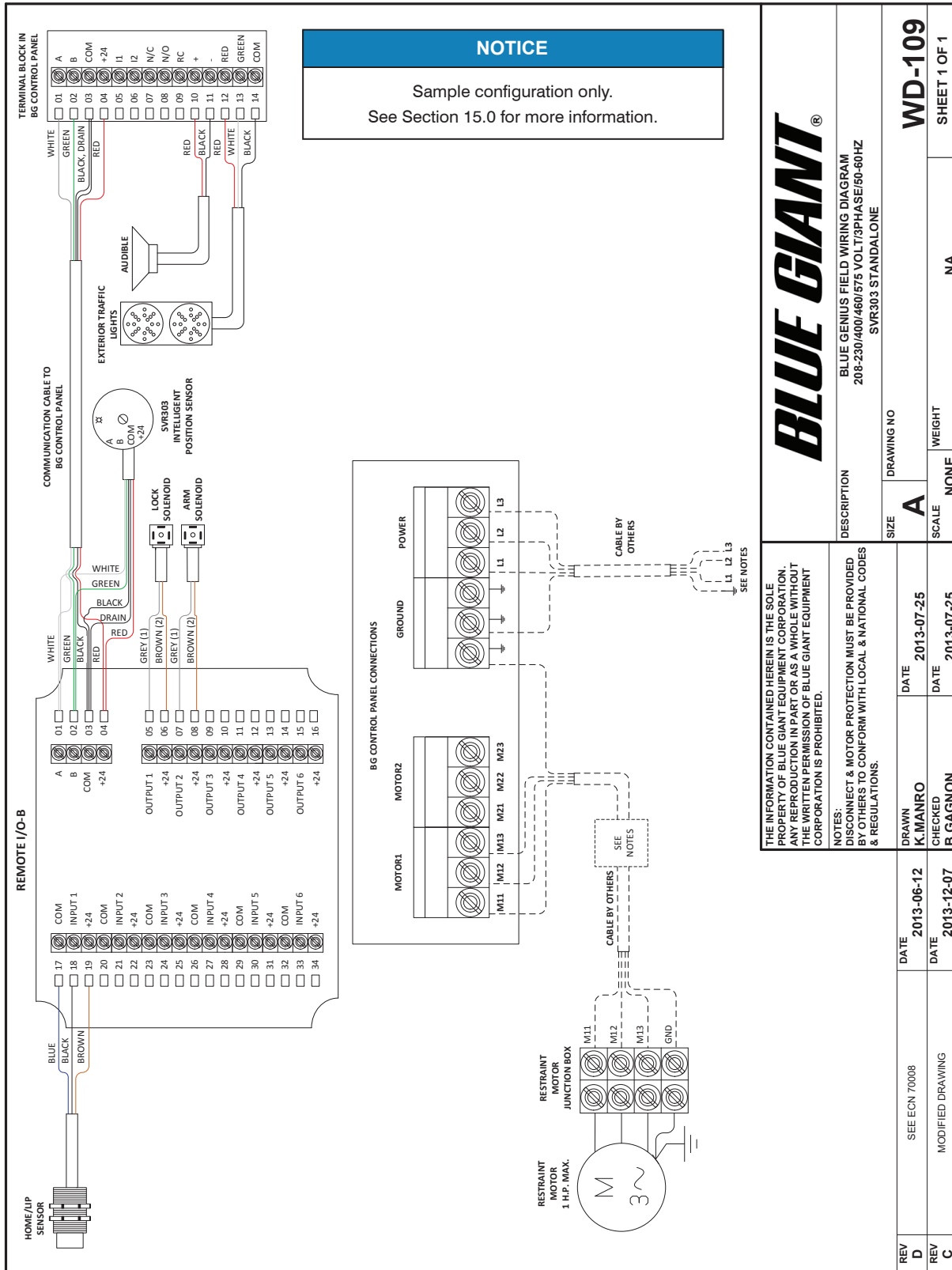

**NOTES**

**NOTES**

**BLUE GIANT**<sup>®</sup>  
BLUE GIANT EQUIPMENT CORPORATION

**Corporate** 410 Admiral Blvd  
Mississauga, ON, Canada L5T 2N6  
t 905.457.3900 f 905.457.2313

**USA** 6350 Burnt Poplar Road  
Greensboro, NC 27409  
[www.bluegiant.com](http://www.bluegiant.com)