

OWNER'S MANUAL

IN-PLANT TILT UPENDER TABLE

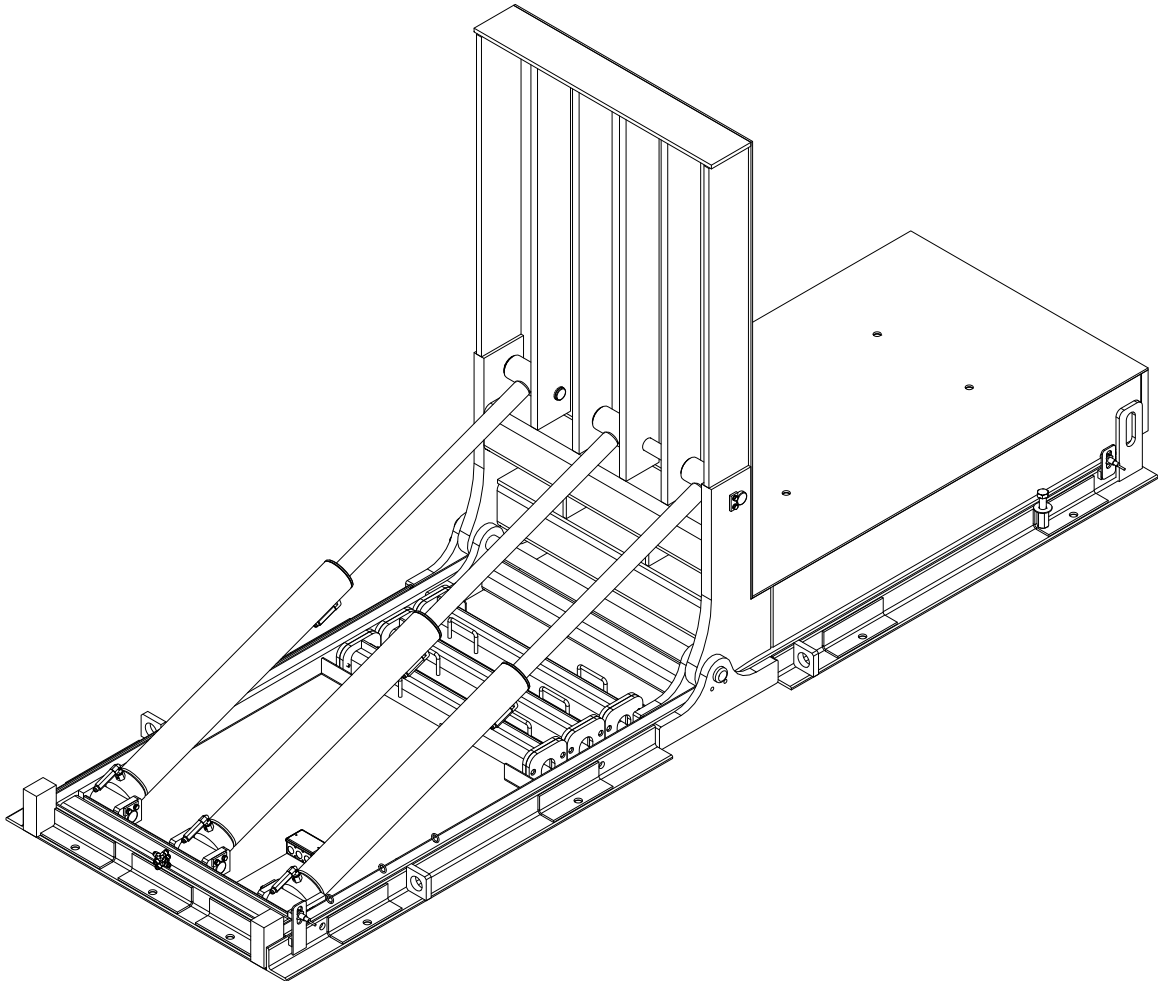

ACTUAL PRODUCT MAY NOT APPEAR EXACTLY AS SHOWN

WARNING

Do not operate or service this product unless you have read and fully understand the entire contents of this manual. Failure to do so may result in bodily injury or death.

BLUE GIANT[®]

Table of Contents

1.0	ABOUT THE IN-PLANT TILT UPENDER TABLE	5
1.1	OWNER'S PURCHASE RECORD	5
2.0	INTRODUCTION	6
2.1	WARRANTY INFORMATION	6
2.2	EXCLUSION OF LIABILITY	6
2.3	MANUFACTURER'S NOTE	7
2.4	OWNER'S RESPONSIBILITY	7
3.0	SAFETY MESSAGE COLOR IDENTIFICATION	8
3.1	OPERATIONAL SAFETY WARNINGS	8
4.0	LOCKOUT / TAGOUT PROCEDURE AND RULES	10
4.1	ELECTROSTATIC SENSITIVE DEVICE PROTECTION POLICY	11
5.0	CONTROL STATION OPERATION	12
5.1	PUSH PEDAL CONTROLS	12
6.0	TILT TABLE MAINTENANCE PINS AND SERVICE STANDS	14
6.1	DEPLOY MAINTENANCE PINS	14
6.2	REMOVE MAINTENANCE PINS	15
6.3	DEPLOY SERVICE STANDS	17
6.4	REMOVE SERVICE STANDS	19
7.0	MAINTENANCE	22
7.1	PLANNED MAINTENANCE PROGRAM (PMP)	22
7.2	OPERATOR DAILY INSPECTION	22
7.3	ROUTINE SERVICING AND MAINTENANCE	22
7.4	PLANNED MAINTENANCE PROGRAM INTERVALS	22
7.5	MAINTENANCE SEQUENCE	22
7.6	DAILY MAINTENANCE PROCEDURES (DMP) CHECKLIST	24
7.7	CHECK POWERPACK RESERVOIR LEVEL	26
8.0	OPERATING INSTRUCTIONS	27
8.1	LOAD TRANSFER	27
8.2	OPERATING THE TILT TABLE	27
8.3	RAISING THE TILT TABLE	27
8.4	LOWERING THE TILT TABLE	28
9.0	RECOMMENDED PARTS	30
9.1	STANDARD OPERATIONAL COMPONENTS	30
9.2	OPTIONAL SUPPORT COMPONENTS	31
9.3	TILT TABLE	32
9.4	TILT TABLE CYLINDERS	32
9.5	TILT TABLE PINS AND RETAINER PLATES	33
9.6	TILT TABLE BUSHING AND WASHERS	33
9.7	FRAME SENSORS	34
9.8	MAINTENANCE STRUTS AND SERVICE STANDS	34
10.0	DECAL IDENTIFICATION AND LOCATION	35
11.0	EQUIPMENT COMPONENT ILLUSTRATIONS	37
11.1	COMPONENTS AS SHIPPED CHECKLIST	37
11.2	TILT UPENDER TABLE MECHANICAL ASSEMBLY	38
11.3	TILT TABLE MECHANICAL ASSEMBLY	40

12.0	POWERPACK PART IDENTIFICATION	41
12.1	HYDRAULIC SCHEMATIC	42
13.0	TROUBLESHOOTING	43
14.0	OPTIONAL EQUIPMENT	45
14.1	SAFETY FEATURES	45

1.0 ABOUT THE IN-PLANT TILT UPENDER TABLE

The Blue Giant In-Plant Tilt Upender Table is a high performance system. The In-Plant Tilt Upender Table Series provides load transfer/ manipulation options for production facilities. The deck is constructed with beams welded at dynamic impact points to provide a sturdy deck support. Hydraulic components increase operating efficiency, operator safety, and reduce maintenance requirements. The tilt function has hydraulic lifts via the facility-integrated, pedal, or hand-held controls.

1.1 OWNER'S PURCHASE RECORD

Please record information for future inquiries and to validate warranty. See "2.1 WARRANTY INFORMATION" on page 6.

Dealer:	Date in Service:
	Number of Units:
Serial Number:	Production Cell#:
Serial Number:	Production Cell#:
Serial Number:	Production Cell#:
Serial Number:	Production Cell#:
Serial Number:	Production Cell#:
Serial Number:	Production Cell#:
Serial Number:	Production Cell#:
Serial Number:	Production Cell#:
Serial Number:	Production Cell#:

The manufacturer offers a full line of in-plant lift tables, twist, tilters, turn tables, safety equipment, accessories, ergonomic equipment, and industrial trucks. Concurrent with a continuing product improvement program, specifications are subject to change without notice (See "2.2 EXCLUSION OF LIABILITY" on page 6). Please contact the your Blue Giant Dealer for latest information. Some features illustrated may be optional in certain market areas.

NOTICE
See "10.0 DECAL IDENTIFICATION AND LOCATION" on page 35 for serial number location.

2.0 INTRODUCTION

The following is a quick reference to important procedures that must be followed while using the In-Plant Tilt Table System. It is not intended to cover, or suggest that it does cover, all procedures necessary to ensure safe operation. All owners and operators should be aware of and abide by all workplace safety regulations applicable to the inspection and operation of the tilt table. These laws and regulations include but are not limited to:

- The Occupational Safety and Health Act
- Canada Occupational Health and Safety Regulations
- Occupational Safety and Health Acts for Individual States (USA), Provinces, or Territories.
- ANSI standard MH29.2

For additional information on these regulations as well as industry standards that may apply to this product, please contact:

American National Standards Institute (ANSI)

1430 Broadway

New York, NY 10018

Telephone: 212.642.4900

www.ansi.org

Lift Manufacturers Product Group (LIFT)

A Product Section of Material Handling Industry of America

A Division of Material Handling Industry

8720 Red Oak Blvd, Suite 201

Charlotte, NC, 28217-3992

Telephone: 704.676.1190

www.mhi.org/lift



2.1 WARRANTY INFORMATION

Thank you for purchasing Blue Giant products. We appreciate your business, and are confident that our product will serve you for many years to come. In the event that you experience a problem with our product, our Customer Support Team is here to support the Blue Giant Product(s) that you have purchased.

To validate warranty on recently purchased equipment, please complete and submit your information with our on-line Warranty Registration at www.BlueGiant.com.

For more information about Blue Giant Warranty Support, please contact your Blue Giant Dealer. You may also visit www.BlueGiant.com or phone 1.800.872.2583.

NOTE: All products must be registered to qualify for warranty.

DEALER INFORMATION

Name:

Contact:

Telephone:

2.2 EXCLUSION OF LIABILITY

To the maximum extent permitted by applicable law, the manufacturer assumes no liability for damage or injury to persons or property that occur as a result of use of the In-Plant Table equipment. Furthermore, to the maximum extent permitted by applicable law, the manufacturer does not assume any liability for lost profits, operating downtimes, consequential, indirect, incidental, special, exemplary, punitive or enhanced damages, or similar losses, whether incurred by owner, authorized users and other third parties. By use of the In-Plant Table equipment, owner assumes all risk of liability for damage or injury to persons or property that occur as a result of use of the In-Plant Table equipment, including, with respect to owner, authorized users and other third parties.

The manufacturer reserves the right to make changes at any time to the modules, components, and accessories, concurrent with its continuing product improvements and development program. Specifications, operating instructions, and illustrations included in this manual are subject to change without advance notice. As the In-plant Tilt Table equipment is a highly customizable product, please contact the manufacturer by telephone at 1.800.872.2583 for the latest information.

2.3 MANUFACTURER'S NOTE

The In-plant Tilt Table equipment has been carefully inspected and tested at the manufacturer's plant prior to shipment, but **MUST be checked** upon receipt for transport damage. Any observed transport damage is to be listed on the signed copy of the freight document. There are many configurations or custom designs whose specifications may not be fully reflected in this manual. Contact your Blue Giant Dealer to obtain the General Arrangement drawing for application specific designs.

Notify the freight forwarder and the dealer of any damage WITHIN 24 HOURS.

2.4 OWNER'S RESPONSIBILITY

The In-plant Tilt Table equipment needs to be maintained and inspected by the owner to verify its safe condition for operation.

1. The owner should recognize the inherent danger of the interface between the In-Plant Table equipment and other components. The owner should, therefore, train and instruct operators in the safe use of the In-Plant Table equipment and accessories in accordance with the manufacturer's recommendations.
2. The owner should thoroughly familiarize themselves with the following procedures and specifications as referenced in this manual, and request immediate replacement of all manufacturer-supplied documents that are missing, damaged, or otherwise illegible.
Owners shall apply sound principles of safety, training, inspection, maintenance, and expected operating environment toward their In-Plant Table equipment usage and maintenance requirements.
 - Commissioning instructions
 - Operating instructions
 - Daily maintenance procedures checklist
 - Inspections procedures
 - Recommended spare parts listsUpon receipt of any newly purchased In-Plant Table equipment, the owner shall verify the presence of owner's manuals, operating placards, and any other documentation necessary for training dock personnel how to use the equipment safely and effectively.
3. All Blue Giant In-Plant Table equipment shall undergo regularly scheduled planned maintenance. Maintenance requirements will vary according to usage frequency and application, so the owner shall contact with their authorized Blue Giant distributor for schedule recommendation. Written records of the performance of these procedures shall be kept as per warranty requirements and per local state or provincial requirements. Please see "7.0 MAINTENANCE" on page 22.
4. In-Plant Table equipment that is structurally damaged, experiencing performance irregularities, or has been potentially compromised shall be removed from service until a trained and authorized manufacturer's representative can conduct an inspection and perform any necessary repairs.
5. As with any piece of machinery, In-Plant Table equipment requires routine maintenance, lubrication, and adjustments. Recommended procedures are itemized in the Planned Maintenance Program (PMP) checklist included in installation and technical manuals. It is recommended that for anything other than the basic maintenance procedures outlined in this manual, please contact your Blue Giant Dealer.
6. The owner shall ensure that all nameplates and safety labels are in place and legible, and that the appropriate manuals are provided to authorized users. Replacement nameplates, safety labels, and manuals are available through the Blue Giant Aftermarket Department. See "10.0 DECAL IDENTIFICATION AND LOCATION" on page 35 in this manual for more information.
7. Unless specifically agreed to in writing by Blue Giant Equipment Corporation at the time of order (and prior to manufacture), all Blue Giant In-Plant Table equipment is sold as a complete offering and must not be altered or added to in any manner (which includes configuration and function) without written permission from an authorized manufacturer's representative. These changes shall also satisfy all safety recommendations of the original equipment manufacturer for the particular application of the In-Plant Table equipment.
8. If, at the request of the owner, Blue Giant does not supply all or some of the In-Plant Table equipment power unit and/or control panel components, the owner shall assume responsibility for any and all operational and safety issues associated with the resulting configuration.
9. The owner must adhere to the load classification information provided on the product nameplate. Failure to do so will void product warranty and can result in serious injury, including death.
10. Operational placard must be visible from equipment location and permanently attached to a wall or structure.
11. The owner shall ensure that inspections are performed to the tilting device as prescribed by law or regulation.

3.0 SAFETY MESSAGE COLOR IDENTIFICATION

This manual includes color-coded safety messages that clarify instructions and specify areas where potential hazard exists. To reduce the possibility of equipment damage and serious injury or death, please follow the instructions and understand the warnings contained in the messages. If warning decals become damaged or missing, replace them immediately. Avoid accidents by recognizing dangerous procedures or situations before they occur.

 DANGER
Serious injury or death will likely occur if the instructions are not followed.

 WARNING
Serious injury or death may occur if the instructions are not followed.

 CAUTION
Instructions marked caution concern safe operating procedure. Failure to comply may result in personal injury.

NOTICE
Procedures marked notice must be followed in order to reduce damage to machinery.

3.1 OPERATIONAL SAFETY WARNINGS

These are safety warnings that may be part of a procedure or hardware warning decal.

 DANGER
<ul style="list-style-type: none"> • BEFORE BEGINNING ANY SERVICE PROCEDURES: <ul style="list-style-type: none"> – Disconnect the power and follow all lockout / tagout procedures, as per OSHA requirements. Refer to wiring diagrams. • Never operate a broken or damaged In-Plant Table. Repair immediately by a qualified service technician. • All loads must be centered and secured from rolling off the platform. Loose or unbalanced loads are dangerous. • While transferring load, be aware of potential fall risks from the tilter table edges. • Failure to properly secure the tilt deck prior to working underneath it may result in bodily injury, or death. • Engage the maintenance pin(s) before working. If the pin(s) cannot be successfully engaged, contact your Blue Giant Dealer.

 WARNING
<ul style="list-style-type: none"> • The tilter hinge is a hazardous pinch point. Do not use fingers or hands to remove foreign materials. • Hinged tilter may drop unexpectedly, keep people and objects clear of the area immediately under or near the tilter. • Post safety warnings and barricade working area around the In-Plant Table and at ground level to reduce unauthorized use of the tilter during maintenance/service. • Operator must be present during all steps of this procedure and keep an unobstructed view of tilter to ensure safe operation. Never leave the In-Plant Table unattended in the tilted position. • Never leave loads sitting on the In-Plant Table. • Do not operate the In-Plant Table beyond its rated capacity. Before load transfers, verify the load does not exceed the single axle rolling load maximum rating as found on nameplate of the In-Plant Table . • Never attempt to lift or hold the tilter table out by hand unless instructed by this manual and using caution. Serious personal injury could occur. • Do not stand in the pathway of the tilt table during the disengagement process in case the tilt table moves unexpectedly.

 **CAUTION**

- Only trained personnel should operate or service this equipment.
- Always park the In-Plant Table equipment after use.
- Conduct routine inspections and maintenance. Failure to do so could cause equipment damage and or personal injury.
- Always contact your Blue Giant Dealer immediately if a malfunction occurs.

NOTICE

- Do not ground welding equipment to any electrical components.
- Do not attach welder as ground to table platform when welding on base frame assembly. Attach welder ground to base frame assembly only.
- Do not allow the drill to go too deeply when drilling holes in the control box. Damage to the control systems may occur.
- Never use air to blow debris from control box. Use a vacuum to remove debris from control box.
- Do not connect green ground lead into control box until all welding has been completed.
- Always keep the work area clean and free of litter.
- Always clean all side openings of dirt and debris.
- Always clean all dirt and debris from the tilter hinge.
- Always clean up dry and liquid spills immediately after they occur.
- Always maintain proper lighting in the work area.
- If a procedure is not clearly defined in this manual, contact your Blue Giant Dealer.

4.0 LOCKOUT / TAGOUT PROCEDURE AND RULES

In accordance with the rules and regulations of the Occupational Safety and Health Administration (OSHA) and/or local jurisdiction, all affected employees must be notified that the machine or equipment will be shut down and locked out to perform repair or maintenance work.

The work area must be checked to verify that all personnel have been removed or safely repositioned.

The machine or equipment power supply shall be locked in the **OFF** position or disconnected from the energy source.

Blue Giant strongly recommends that only OSHA-approved and/or local jurisdiction lockout devices and procedures be utilized.

The energy isolating device must bear a prominent warning tag indicating that work is being done on the equipment and the name of the authorized employee responsible for the lockout.

It is mandatory that tagout notices shall **NOT** be susceptible to deterioration or illegibility due to weather conditions, exposure to chemicals, and/or moisture.

WARNING

- Always lockout and tagout any power source before performing any work on any electrical devices or electrical controls according to OSHA regulations and approved local electrical codes. Refer to wiring diagrams.

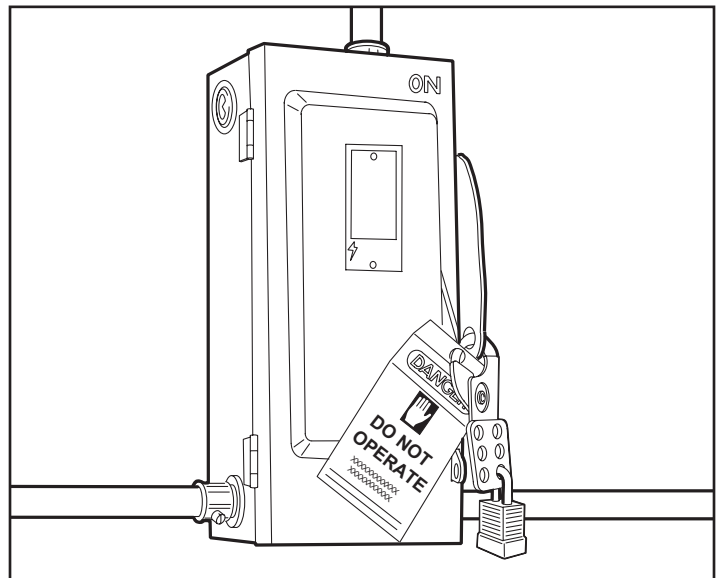

An example of lockout / tagout. Verify and comply with local codes/ regulatory requirements.

4.1 ELECTROSTATIC SENSITIVE DEVICE PROTECTION POLICY

This policy applies to static sensitive electronic products primarily printed circuit boards (PCBs) and sensors. Switches, relay, lamps and wire are not sensitive and do not apply.

If welding near ESD components, correctly protect and ground all necessary equipment.



1. Prior to handling PCBs, wear a static grounding wrist strap and clip it to an electrical ground. The metal plate on the inside of the wristband must be in contact with the wearers skin.
2. PCBs should never be handed to other personnel or set down anywhere.
3. Place PCBs in black ESD shielding bags for return or storage. Only one PCB or sensor should be placed in a static bag. Attach paperwork and other items to the outside with adhesive pouches or elastic bands.
4. The control boxes protect the PCBs inside from static, and should not be used to store manuals or other accessories.

5.0 CONTROL STATION OPERATION

As the In-Plant Tilt Upender Table is part of an assembly line environment, the wiring diagrams will give the correct control setup and use.

5.1 PUSH PEDAL CONTROLS

DANGER

- While Tilt Upender Table is moving, keep people and objects clear of areas under the platform and in the immediate tilter area.
- Fully read and understand the tilter operation. Practice safe load transfer methods. If you do NOT understand the complete tilt operating procedure and safe load transfer methods, refer to the Owner/Operator regarding local regulatory/jurisdictional and facility requirements.

WARNING

- If presence required, operator(s) must be present during all steps of this procedure.
- Operator(s) must keep an unobstructed view of Tilt Upender Table, any operation light/horn/bell, and other operators to ensure safe operation.
- Do not exceed (rated/tilting) capacity or load classification of tilter as listed on the manufacturer/product nameplate. Capacity includes: manual equipment, pallet(s), material(s)/goods, and any other objects on the deck/platform. See “2.4 OWNER'S RESPONSIBILITY” on page 7. For nameplate location, see “10.0 DECAL IDENTIFICATION AND LOCATION” on page 35.
- To avoid bodily injury, stand clear of Tilt Upender Table while it is moving.

Depending on the in-plant installation, the Tilt Upender Table may have facility-integrated, pedal, or hand-held controls available. Consult the specific installation wiring diagram for these options, if present.

• UP push pedal

The **UP** push pedal control starts the hydraulic Powerpack to apply pressure via the lift cylinders and raise the deck of the tilt table at a safe speed.

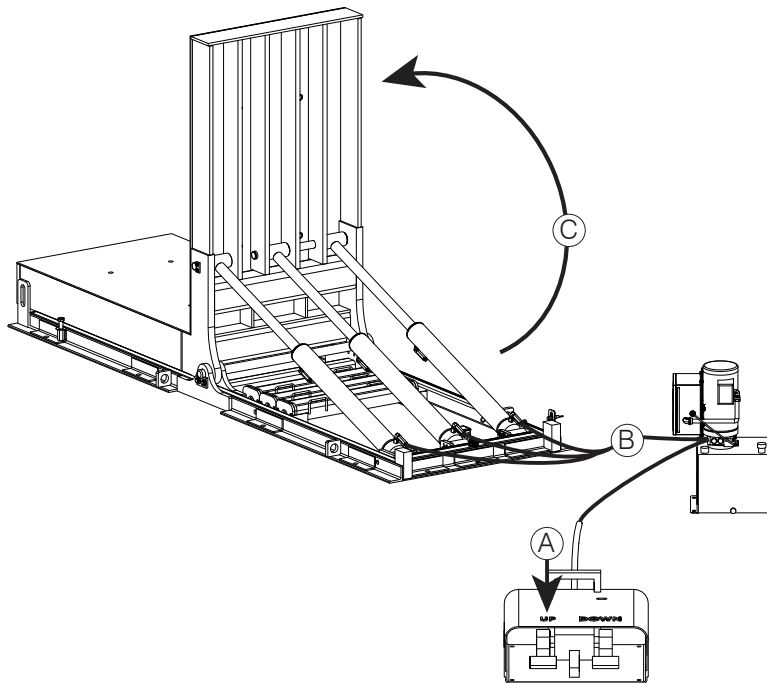

Callout	Description
A	Press the UP push pedal
B	Powerpack delivers oil to cylinders increasing hydraulic pressure on the extending side of cylinder
C	Direction of Deck travel

• **DOWN push pedal**

The **DOWN** push pedal control starts the hydraulic Powerpack to apply pressure to the retracting side of the cylinders. This causes the tilt table to lower at a controlled and safe speed.

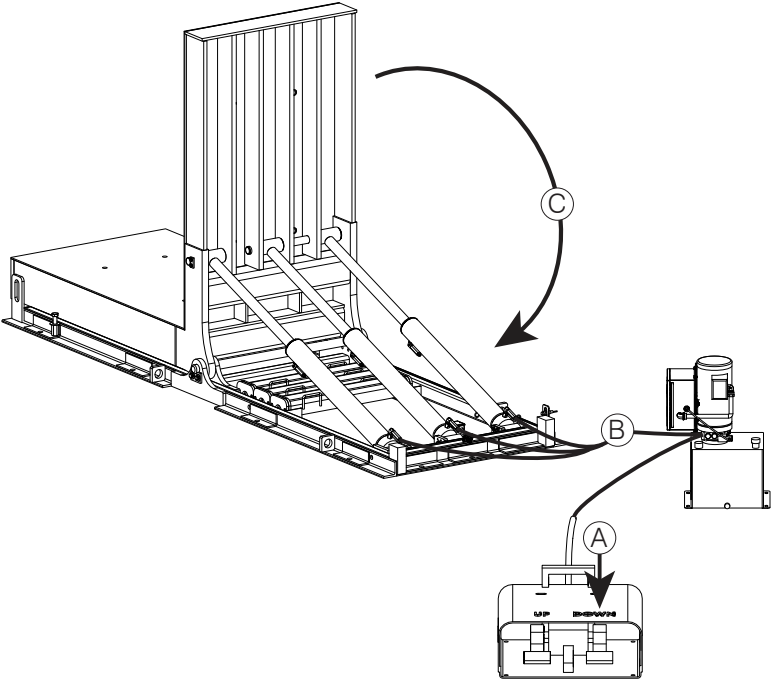

Callout	Description
A	Press the DOWN push pedal
B	Powerpack releases oil back into reservoir and increases the hydraulic pressure on the retracting side of cylinder
C	Direction of Deck travel

6.0 TILT TABLE MAINTENANCE PINS AND SERVICE STANDS

This section describes the different functions of the Tilt Maintenance Pins. These procedures require at least temporary electrical power for the Powerpack to raise and lower the Tilt table.

6.1 DEPLOY MAINTENANCE PINS

If access to the space under the tilt table is required then deploy the Tilt Table Maintenance Pins then the Service Stands before placing any body part in or under these areas.

For visual inspections, only the Maintenance Pins need to be deployed, but deploying the Services Stands is recommended.

DANGER

- Failure to properly secure the tilt table prior to working underneath it may result in bodily injury, or death.
- Engage the Maintenance Pins on the tilt table AND the Service Stands before working under or near table. If the Maintenance Pins cannot be successfully engaged, contact your Blue Giant Dealer.

WARNING

- Post safety warnings and barricade work area at tilt table level. Notify all affected personnel that work is being performed on the unit and follow proper lock-out procedure. Verify that power to the unit has been completely cut off and cannot be turned back on accidentally, as per OSHA requirement.
- Head protection and other applicable PPE is recommended when working under or around the raised deck.
- Maintenance Pins and Service Stands must be used when working under the table. (i.e. more than cleaning or visually inspecting)
- Do not stand in the pathway of the tilt table during the disengagement process in case the table falls unexpectedly.

CAUTION

- It is recommended that this procedure be performed with assistance.

1. Raise the tilt table to a height sufficient to deploy the two (2) Maintenance Pins.

NOTE: Perform the following steps for both Tilt Table Maintenance Pins.

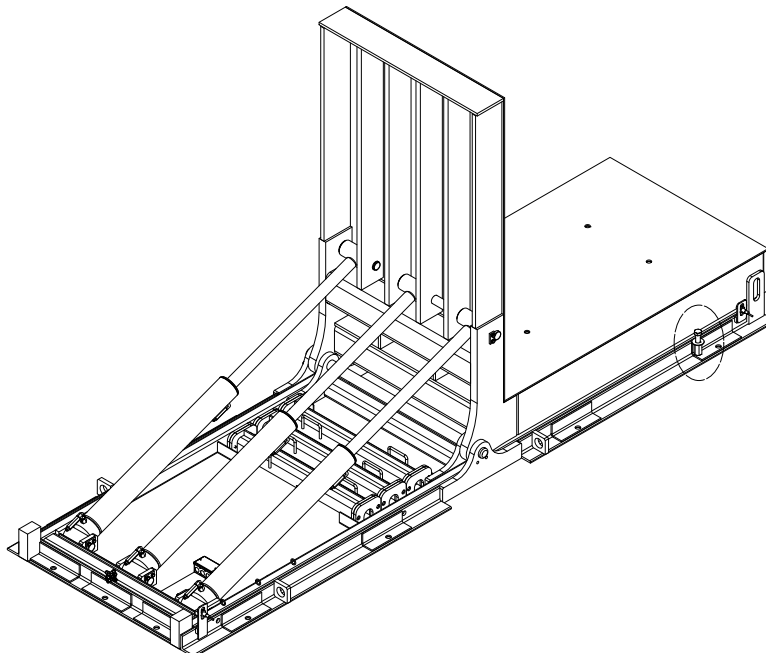

- Remove the Maintenance Pin from the holder in the lower frame then attach the Maintenance Pin into the tilt table anchor bracket on each lower frame side.

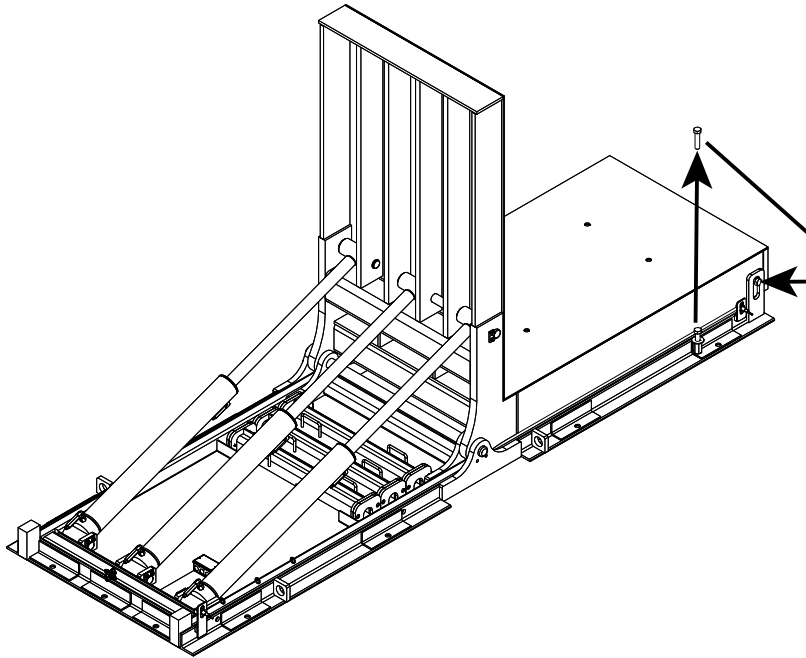

- Verify that the Maintenance Pin is firmly supporting the tilt table at the anchor bracket.
- Repeat steps 2 to 3 for the opposite Maintenance Pin.
- Verify that both Maintenance Pins are solidly in place before working near or around the tilt table.
Adjust the Maintenance Pins, if required.

6.2 REMOVE MAINTENANCE PINS

Remove the Maintenance Pins for the tilt table and return to full operation.

DANGER

- Failure to properly secure the tilt table prior to working underneath it may result in bodily injury, or death.
- Engage the Service Stands AND the Maintenance Pins on the tilt table before working. If the Maintenance Pins cannot be successfully engaged, contact your Blue Giant Dealer.

WARNING

- Post safety warnings and barricade work area at tilt table. Notify all affected personnel that work is being performed on the unit and follow proper lock-out procedure. Verify that power to the unit has been completely cut off and cannot be turned back on accidentally, as per OSHA requirement.
- Head protection and other applicable PPE is recommended when working under or around the raised deck.
- Maintenance Pins and Service Stands must be used when working under the table. (i.e. more than cleaning or visually inspecting)
- Do not stand in the pathway of the tilt table during the disengagement process in case the table falls unexpectedly.

CAUTION

- It is recommended that this procedure be performed with assistance.

- Remove both Maintenance Pins from the tilt table anchor brackets then return the Maintenance Pins to the lower frame side storage holders.

NOTE: Perform the following steps for both Tilt Table Maintenance Pins.

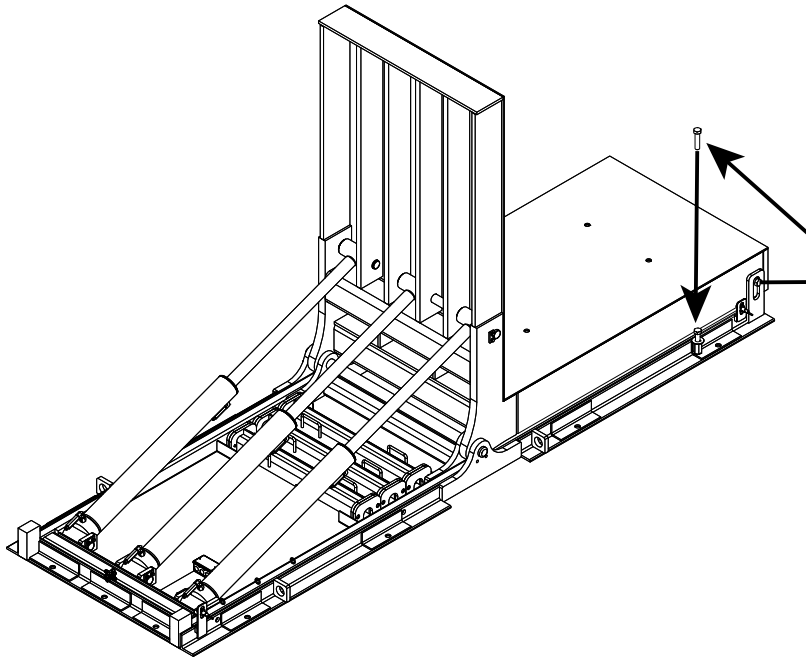

2. Verify that both Maintenance Pins are solidly stored in the lower frame storage holders before returning to work. Adjust the Maintenance Pins, if required.

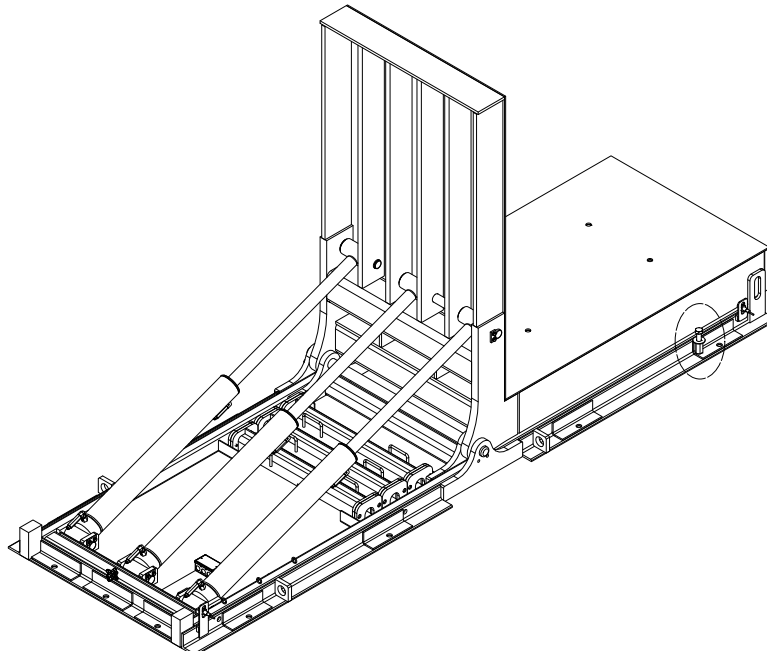

3. Remove any lock out and tag out.

6.3 DEPLOY SERVICE STANDS

If access to the space under the tilt table is required then deploy the Tilt Table Maintenance Pins then the Service Stands before placing any body part in or under these areas.

DANGER

- Failure to properly secure the tilt table prior to working underneath it may result in bodily injury, or death.
- Engage the Maintenance Pins on the tilt table AND the Service Stands before working on or under the table. If the Maintenance Pins cannot be successfully engaged, contact your Blue Giant Dealer.

WARNING

- Post safety warnings and barricade work area at tilt table and ground level. Notify all affected personnel that work is being performed on the unit and follow proper lock-out procedure. Verify that power to the unit has been completely cut off and cannot be turned back on accidentally, as per OSHA requirement.
- Head protection and other applicable PPE is recommended when working under or around the raised deck.
- Maintenance Pins and Service Stands must be used when working under the table. (i.e. more than cleaning or visually inspecting)
- Do not stand in the pathway of the tilt table during the disengagement process in case the table falls unexpectedly.

CAUTION

- It is recommended that this procedure be performed with assistance.

1. If not already in position, raise the tilt table and verify that the two (2) Maintenance Pins are deployed.

NOTE: Perform the following steps for all three (3) Tilt Table Service Stands before attempting servicing near or under table.

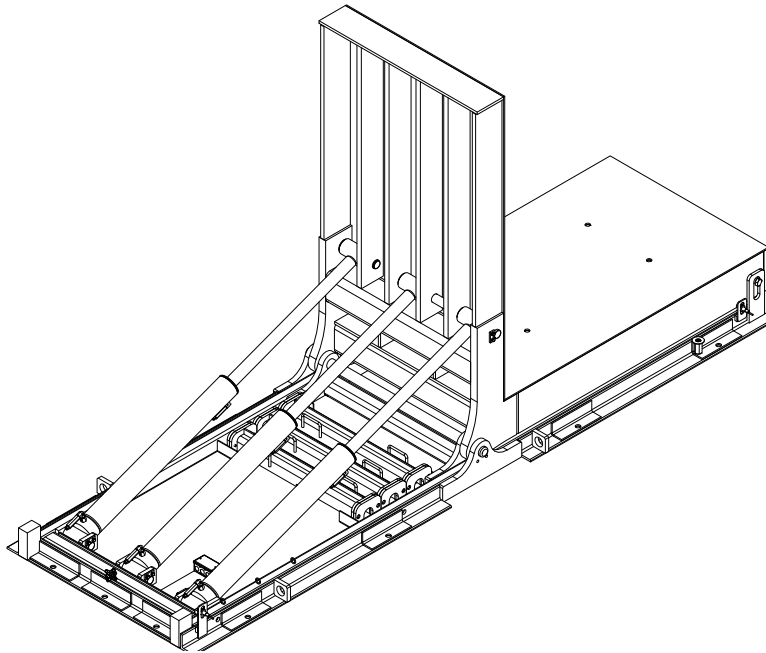

2. Remove a Maintenance Stand from the holders in the lower frame of the table.

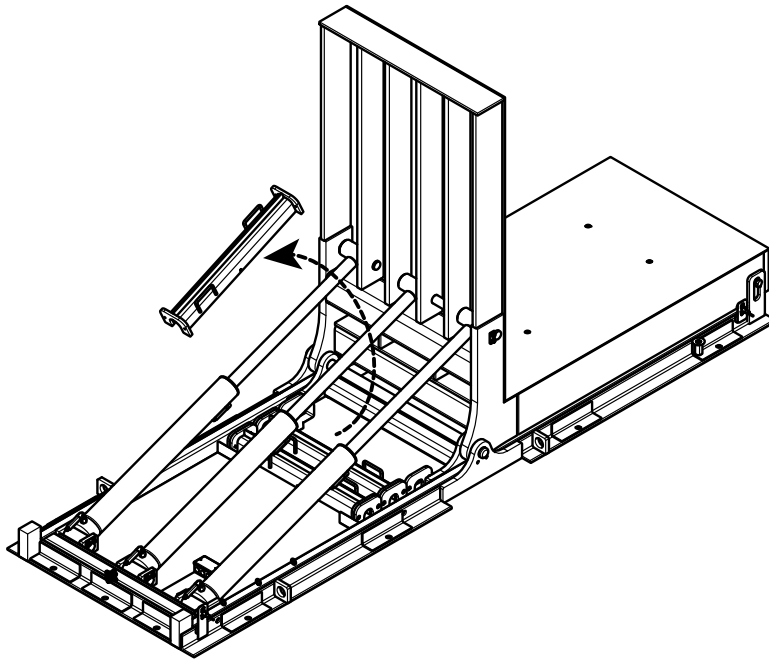

3. Position the Service Stand onto the exposed section of an extended hydraulic cylinder.

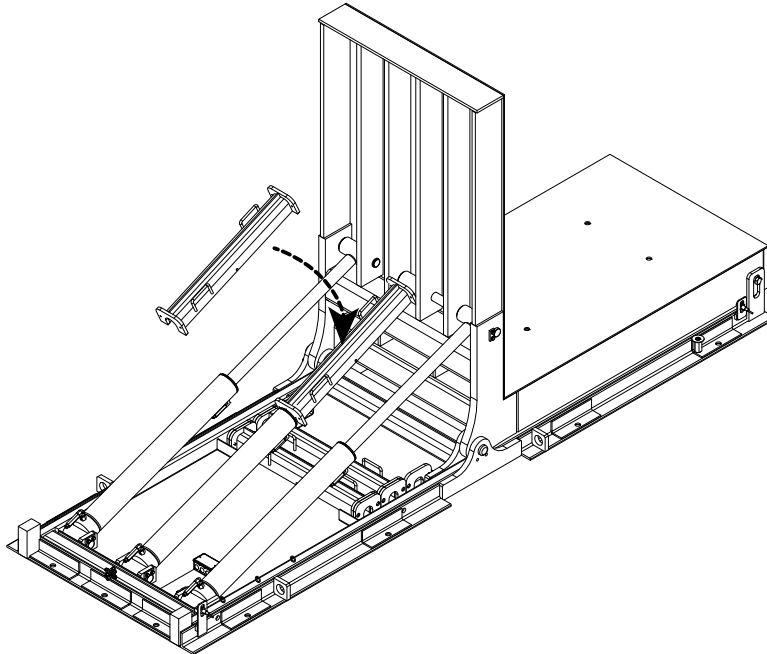

4. Verify that the Service Stand is firmly supporting the tilt table at the anchor location.
5. Repeat steps 2 to 4 for the remaining Service Stands.
6. Verify that all three (3) Service Stands are solidly in place before working near or around the tilt table.
Adjust the Service Stands, if required.

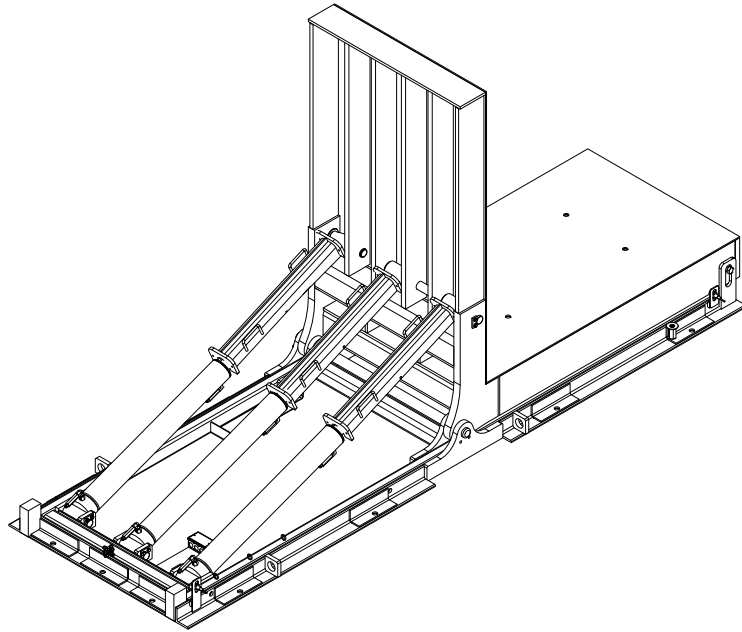

7. Proceed with work under the table.

6.4 REMOVE SERVICE STANDS

When the work under the tilt table is completed, remove the Service Stands then the Maintenance Pins.

DANGER

- Failure to properly secure the tilt table deck prior to working underneath it may result in bodily injury, or death.
- Engage the Maintenance Pins on the tilt table AND the Service Stands before working on or under the table. If the Maintenance Pins cannot be successfully engaged, contact your Blue Giant Dealer.

WARNING

- Post safety warnings and barricade work area at tilt table and ground level. Notify all affected personnel that work is being performed on the unit and follow proper lock-out procedure. Verify that power to the unit has been completely cut off and cannot be turned back on accidentally, as per OSHA requirement.
- Head protection and other applicable PPE is recommended when working under or around the raised deck.
- Maintenance Pins and Service Stands must be used when working under the table. (i.e. more than cleaning or visually inspecting)
- Do not stand in the pathway of the tilt table during the disengagement process in case the table falls unexpectedly.

CAUTION

- It is recommended that this procedure be performed with assistance.

1. Once work is completed, prepare to remove the Service Stands from under the raised tilt table.

NOTE: Perform the following steps for all three (3) Tilt Table Service Stands before attempting servicing near or under table.

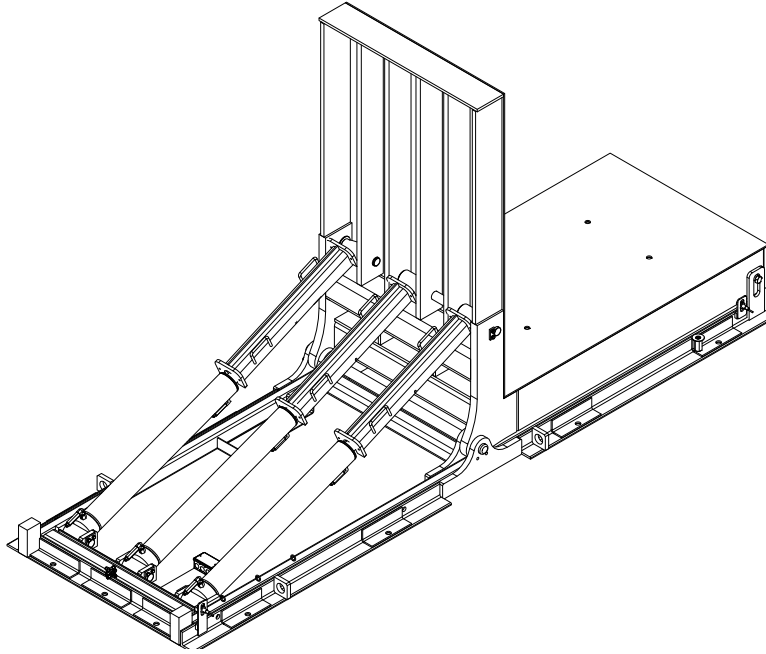

2. Remove a Service Stand from an exposed section of an extended hydraulic cylinder.

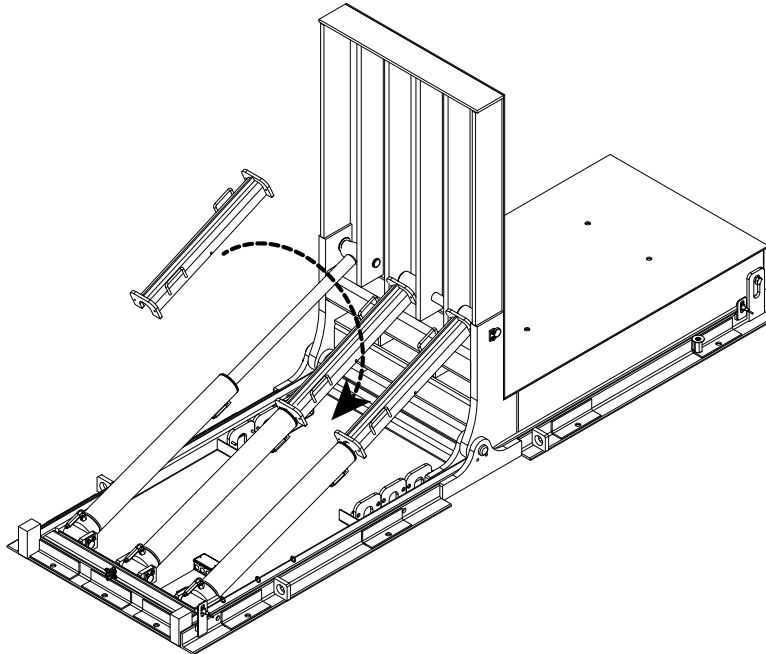

3. Return the Service Stand to storage location in the lower frame.

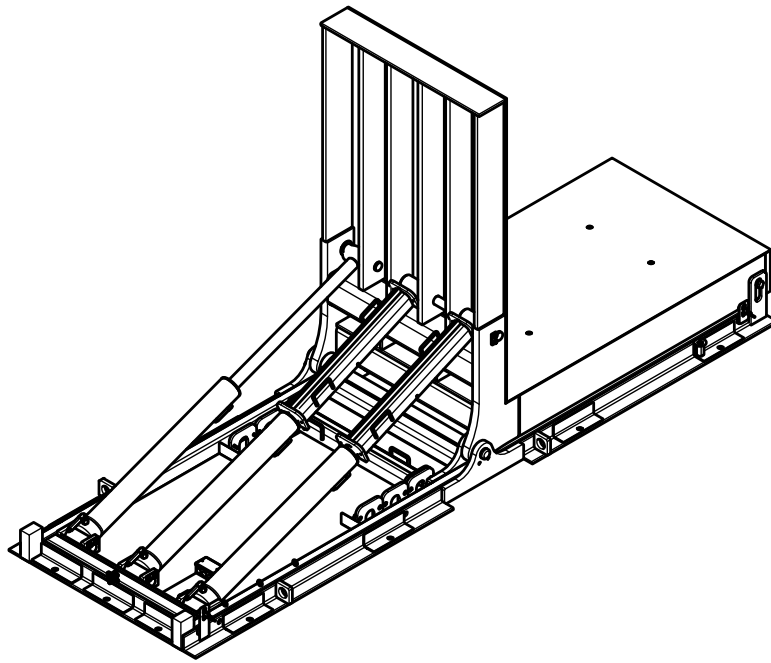

4. Verify that the Service Stand is firmly stored in the lower frame and clear of the paths of any moving parts.
5. Repeat steps 2 to 4 for the remaining Service Stands.
6. Verify that all three (3) Service Stands are correctly and solidly stored in place before continuing.

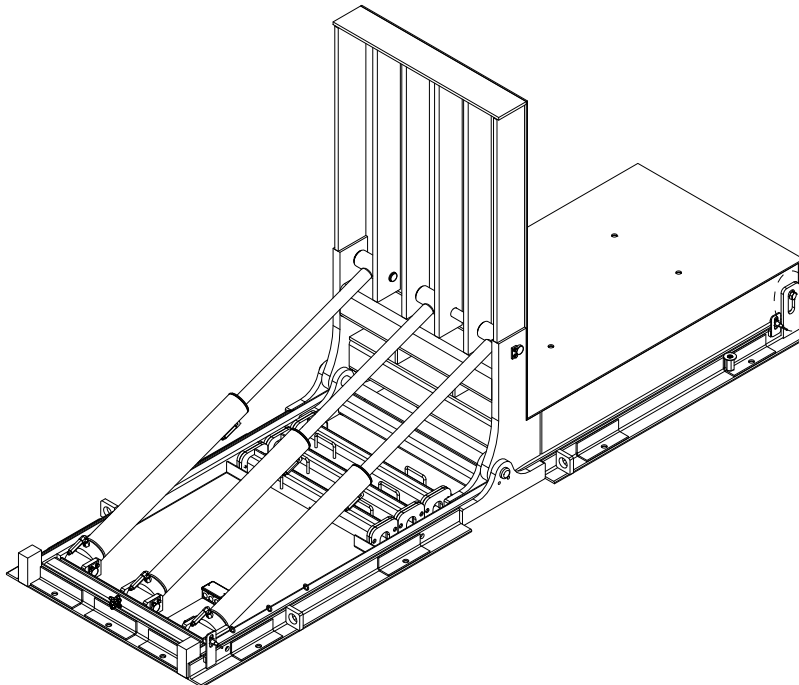

7. Remove any lock out and tag out.

7.0 MAINTENANCE

Develop a planned or scheduled maintenance plan to keep the Tilt Upender Table in good operating order.

DANGER

- Failure to properly secure the Tilt Upender Table decks prior to working underneath it may result in bodily injury, or death.
- Engage the Tilt Maintenance Pins before working. If the pin(s) cannot be successfully engaged, contact your Blue Giant Dealer.

WARNING

- Do not attempt to install, make repairs, or adjustments. Only a trained and authorized service technician should perform the installation process, make repairs, or make adjustments. Contact your Blue Giant Dealer for assistance.
- Do not service this equipment until you have read and understood all of the safety information and instructions contained herein. Failure to adhere to recommended safety practices in this manual and on the Tilt Upender Table equipment warning labels could result in death or serious injury.
- Do not conduct maintenance or repairs until adequate barriers have been placed to keep production, warehouse, and vehicle traffic away from the work area.
- Before doing any electrical work, verify that the power is disconnected and properly tagged or locked out.
- When conducting maintenance, use only Blue Giant approved lubricants. Improper lubrication or adjustments may cause operational problems.

7.1 PLANNED MAINTENANCE PROGRAM (PMP)

In addition to the Daily Maintenance Procedures (DMP), the manufacturer recommends (and local government regulations may require) that a Planned Maintenance Program (PMP) and safety inspection program be performed by a trained and authorized service technician on a regular basis to ensure the equipment is in safe operating condition. The PMP will provide an opportunity to make a thorough inspection of the safety and operating condition of the Tilt Upender Table. Necessary adjustments and repairs can be done during the PMP, which will increase the life of components and reduce unscheduled downtime.

Recommended procedures for a periodic planned maintenance program that covers inspections, operational checks, cleaning, lubrication, and minor adjustments are outlined in the Owner's Manual for this product. Contact your Blue Giant Dealer regarding for assistance with a planned maintenance program by offering trained service personnel with expertise in Tilt Upender Table maintenance requirements.

7.2 OPERATOR DAILY INSPECTION

The Tilt Upender Table shall always be examined by the operator **PRIOR TO ANY USE** to verify that it is safe to operate.

The manufacturer recommends scanning to storage or making multiple photocopies of the DMP Checklist. The operator should fill out this form to keep a daily record of operation and maintenance issues. See "7.6 DAILY MAINTENANCE PROCEDURES (DMP) CHECKLIST" on page 24.

7.3 ROUTINE SERVICING AND MAINTENANCE

Regular maintenance and care of the Tilt Upender Table is very important for operator safety, operation efficiency, and cost. A faulty Tilt Upender Table is a potential source of danger to the operator, and to other personnel working near it. As with all quality equipment, keep the Tilt Upender Table in good operating condition by following the recommended schedule of maintenance. Failure to properly maintain or operate the Tilt Upender Table within its rated load classification can void the manufacturer warranty.

7.4 PLANNED MAINTENANCE PROGRAM INTERVALS

Arrange for a qualified Tilt Upender Table repair technician to perform regularly scheduled planned maintenance on your Tilt Upender Table every three months for single shift operations or monthly for multi-shift operations. Call your authorized manufacturer / dealer for further details.

7.5 MAINTENANCE SEQUENCE



Follow this procedure for maintenance of the Tilt Upender Table.

1. Cleaning, including under tilt table and lower frame.
2. Visual inspection of all components.

3. Lubrication, as required (by a trained service technician only).
4. Test operate all functions.
5. Adjustments, if required (by a trained service technician only).
6. Record inspection details and findings for owners' files.

7.6 DAILY MAINTENANCE PROCEDURES (DMP) CHECKLIST

Use checklist to aid the daily maintenance inspection.

 DANGER
<ul style="list-style-type: none">• When repairing or conducting maintenance procedures on electrical components, perform lockout / tagout steps according to OSHA regulations and approved electrical codes.• Prior to inspection, place adequate barriers to reduce unauthorized personnel and vehicle traffic from entering the work area.
 CAUTION
<ul style="list-style-type: none">• All repairs and maintenance work are to be conducted by trained and authorized personnel ONLY.

Forward this checklist to the person responsible for Tilt Upender Table equipment maintenance. See "Owner's Purchase Record" for Date in Service.

INSTRUCTIONS: Indicate "OK for USE" with a check mark ✓ in the appropriate box of each inspection point. Indicate "NOT OK for USE" with an x in the appropriate box of each inspection point.

EVERY DAY (MAY BE PERFORMED BY OWNER OR ATTENDANT):

- Remove any debris that may have accumulated around the Tilt Upender Table equipment.
- Verify complication-free operation of the Tilt Upender Table equipment.
- Remove any potential trip hazards from around the Tilt Upender Table area.
- Verify that instructional caution and danger labels are present and legible on the product. Replace if necessary.
- Verify if the hydraulic system has any leaks (oil drops/pooling), loose fittings, or cracked/rotted/sliced hoses.
- Verify if the Tilt Upender Table has developed a tilt (unusual position), any visible damage, or produces unusual noises while moving.
- Verify complication free operation of the equipment through a complete cycle (refer to Operation Placard).
- _____
- _____

SCAN TO STORAGE OR PHOTOCOPY THIS CHECKLIST AND FILL OUT REGULARLY FOR YOUR RECORDS.

Explain faults briefly in the space provided below:



DEALER: _____

PLANNED MAINTENANCE PROGRAM - PMP CHECKLIST

Tilt Upender Table

Customer:		SWO#		
Location:		Date:		
Contact:	Telephone:	Inspected By:		
Signature:	Model / Serial #:	Voltage:	Phase:	HP:

WARNING

NOTE TO TECHNICIAN: ALL ITEMS ON LIST MUST BE VERIFIED AND CHECKED. ITEMS WITH AN * REQUIRE LUBRICATION.	Position #	Position #	Position #	Position #	Position #
	✓	✓	✓	✓	✓
	Barricade area				
Disconnect power per OSHA requirements					
Clean debris from in and around Tilt Upender Table					

Mark the following with one of the following: ✓ = GOOD X = COMMENTS / REQUIRES REPAIR	Position #		Position #		Position #		Position #		Position #	
	✓	X	✓	X	✓	X	✓	X	✓	X
Pit or mount area										
Deck hinges										
Wire harness / cables										
Hydraulic hose assembly										
Cylinders										
Structural damage										
Electrical connectors										
Lowering speed flow control (If present)										
Pin bushings *										
Tilt Table Maintenance Pins										
Tilt Table Safety Stands										
Check that operational placard present and legible (if present)										
Complete operating cycle for proper sequence.										

Unit Certified for Maximum Tilt Capacity	Position #	Comments (for items marked with an X):

The noted equipment has been checked, inspected and serviced by a trained technician.

7.7 CHECK POWERPACK RESERVOIR LEVEL

Only trained technicians should fill the Powerpack reservoir. Contact your Blue Giant Dealer regarding oil options.

WARNING

- Do not attempt to install, make repairs, or adjustments. Only a trained and authorized service technician should perform the installation process. Contact your Blue Giant Dealer.
- Do not service this equipment until you have read and understood all of the safety information and instructions contained herein. Failure to adhere to recommended safety practices in this manual and on the Tilt Upender Table equipment warning labels could result in death or serious injury.
- Do not conduct maintenance or repairs until adequate barriers have been placed to keep warehouse and vehicle traffic away from the work area.
- Before doing any electrical work, make certain the power is disconnected and properly tagged or locked out, in accordance with OSHA regulations and approved electrical codes.
- When conducting maintenance, use only Blue Giant approved lubricants. Improper lubrication or adjustments may cause operational problems.

1. Inspect and top up Remote Powerpack reservoir, while Tilt Upender Table is in the lowered position.
2. If powerpack is mounted under the tilt table then proceed with steps 3 to 7.
3. Without a load on the tilter deck, raise the Tilt Upender Table to sufficient height to deploy the Maintenance pins.
4. Deploy the Tilt Table Maintenance Pin. See “6.1 DEPLOY MAINTENANCE PINS” on page 14.
5. Deploy the Tilt Table Safety Stands. See “6.3 DEPLOY SERVICE STANDS” on page 17.
6. Perform a lockout/tag out.
7. Refer to site specifications for any lubrication information.
8. When reservoir filled to normal level, remove lockout/tagout.
9. Remove Maintenance Pins
10. Cycle five (5) times. If successful then return to service. Consult Blue Giant for further assistance.

8.0 OPERATING INSTRUCTIONS

Depending on the in-plant installation, the Tilt Upender Table may have controls available. This manual refers to the foot pedal controlled units. Consult the specific installation wiring diagram for these options, if present.

8.1 LOAD TRANSFER

When transferring loads onto and off of a Tilt Upender Table, the cargo weight distribution should **NEVER** exceed the maximum value on the weight rating decal. The Tilt Upender Table weight rating decal lists the maximum load values for the Tilt Upender Table.

8.2 OPERATING THE TILT TABLE

Refer to site documentation for specific control options. This manual refers to tilt tables controlled by a dual pedal control unit.

8.3 RAISING THE TILT TABLE

Refer to site documentation for specific control options. The following Dangers and Warnings apply to any Tilt Upender Table.

DANGER

- While Tilt Upender Table is moving, keep people and objects clear of areas under the platform and in the immediate Tilt Upender Table area.
- Fully read and understand the Tilt Upender Table operation. Practice safe load transfer methods. If you do NOT understand the complete Tilt Upender Table operating procedure and safe load transfer methods, refer to the Owner/Operator regarding local regulatory/jurisdictional and facility requirements.
- While monitoring the Tilt Upender Table, be aware of potential fall risks from deck and tilter edges.

WARNING

- Tilt Upender Table operator(s) must be present during all steps of this procedure.
- Tilt Upender Table operator(s) must keep an unobstructed view of Tilt Upender Table, any operation light/horn/bell, and other operators to ensure safe operation.
- Do not exceed (rated/Tilt Upender Table) capacity or load classification of Tilt Upender Table as listed on the manufacturer/product nameplate. Capacity includes: any object(s) on the deck/platform. See "2.1 WARRANTY INFORMATION" on page 6. For nameplate location, see "10.0 DECAL IDENTIFICATION AND LOCATION" on page 35.
- To avoid bodily injury, stand clear of Tilt Upender Table while it is moving.

Read and understand these instructions and safety rules before operating Tilt Upender Table:

- Before using Tilt Upender Table, inspect it for proper operation and condition. If any unsafe condition exists, remove unit from service until repairs are made.
 - Before using Tilt Upender Table, inspect any/all safety devices to verify that they are in place and functioning properly.
 - Prior to placing a load on Tilt Upender Table, read and understand the rated capacity of the unit, as labeled on the nameplate attached to the side of the deck assembly. The rated Tilt Upender Table capacity is the maximum uniformly distributed load permitted for the unit.
1. Verify that the lift is readied for use. Power is **ON** and the tilt table is in the lowered position without a lockout/tagout.
 2. If a load is:
 - present on the table, verify that it is centered on the table surface.
 - requires loading, transfer load so that it is centered on the table surface.
 - absent, proceed with procedure.

3. On the tilt table control, press and hold the **UP** foot pedal to tilt table completely then release pedal.

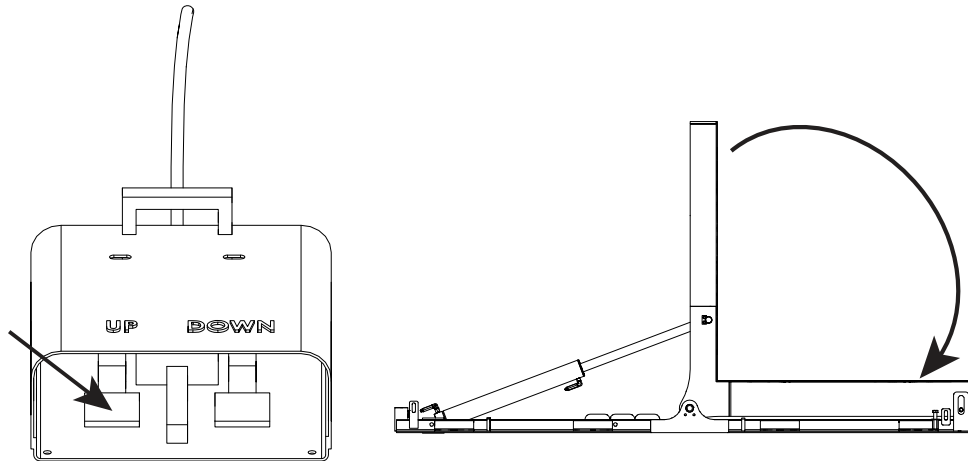

4. Proceed with required procedures.

8.4 LOWERING THE TILT TABLE

Refer to site documentation for specific control options. The following Dangers and Warnings apply to any Tilt Upender Table.

DANGER

- While Tilt Upender Table is moving, keep people and objects clear of areas under the platform and in the immediate Tilt Upender Table area.
- Fully read and understand the Tilt Upender Table operation. Practice safe load transfer methods. If you do NOT understand the complete Tilt Upender Table operating procedure and safe load transfer methods, refer to the Owner/Operator regarding local regulatory/jurisdictional and facility requirements.
- While monitoring the Tilt Upender Table, be aware of potential fall risks from deck and tilter edges.

WARNING

- Tilt Upender Table operator(s) must be present during all steps of this procedure.
- Tilt Upender Table operator(s) must keep an unobstructed view of Tilt Upender Table, any operation light/horn/bell, and other operators to ensure safe operation.
- Do not exceed (rated/Tilt Upender Table) capacity or load classification of Tilt Upender Table as listed on the manufacturer/product nameplate. Capacity includes: any object(s) on the deck/platform. See "2.1 WARRANTY INFORMATION" on page 6. For nameplate location, see "10.0 DECAL IDENTIFICATION AND LOCATION" on page 35.
- To avoid bodily injury, stand clear of Tilt Upender Table while it is moving.

Read and understand these instructions and safety rules before operating Tilt Upender Table:

- Before using Tilt Upender Table, inspect it for proper operation and condition. If any unsafe condition exists, remove unit from service until repairs are made.
 - Before using Tilt Upender Table, inspect any/all safety devices to verify that they are in place and functioning properly.
 - Prior to placing a load on Tilt Upender Table, read and understand the rated capacity of the unit, as labeled on the nameplate attached to the side of the deck assembly. The rated Tilt Upender Table capacity is the maximum uniformly distributed load permitted for the unit.
1. Verify that the lift is readied for use. Power is **ON** and the tilt table is in the raised position without a lockout/tagout.
 2. If a load is:
 - present on the table, verify that it is centered on the table surface.
 - requires loading, transfer load so that it is centered on the table surface.
 - absent, proceed with procedure.

3. On the tilt table control, press and hold the **DOWN** foot pedal to tilt table completely then release pedal.

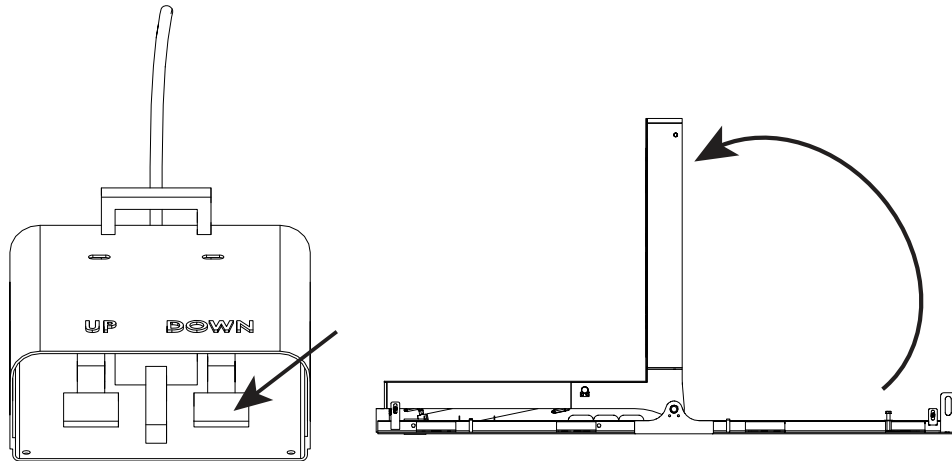

4. Proceed with required procedures.

9.0 RECOMMENDED PARTS

9.1 STANDARD OPERATIONAL COMPONENTS

TILT TABLE STANDARD OPERATIONAL COMPONENTS			
ITEM	QTY	PART NO.	DESCRIPTION
3	3	780-144-294-DA	CYLINDER ASSY (3-1/2"DIA), ED/FS/DS [29 1/2" STROKE], D/A
4	2	018-125	SPHERICAL BEARING, 1.75" ID, MAINT FREE
5	12	018-099	BUSHING, PLASTIC, 1 1/2in ID x 2in L
6	16	105-894	THRUST WASHER FLAT 1.75"ID X 2.75"OD X 0.0585"THK IGUS GTI-2844-01
7	14	105-884	THRUST WASHER FLAT 1-1/2"ID X 2-1/2"OD X 0.0585"THK IGUS GTI-2440-01
8	3	2021512	PIN, 1 1/2" OD X 6.375" L SUPERIOR SHAFTING
9	1	2021453	PIN, 1 3/4" OD X 40" L SUPERIOR SHAFTING
10	1	2021459	PIN, 1 1/2" OD X 9.375" L SUPERIOR SHAFTING
11	1	2021511	PIN, 1 1/2" OD X 23" L SUPERIOR SHAFTING
28	3	033-538	EXCESS FLOW PROTECTOR 2 GPM, 6FNPT-6MJIC
29	3	033-533	EXCESS FLOW PROTECTOR 1.75 GPM, 6FNPT-6MJIC
36	2	028-209	PROXIMITY SENSOR - XS618B1MBL2-N/C
35	1	033-892	POWERPACK 5HP 208-230 460V/3/60 INT. VER 8GAL
37	1	026-224	FOOT SWITCH

9.2 OPTIONAL SUPPORT COMPONENTS

TILTER TABLE OPTIONAL COMPONENTS			
ITEM	QTY	PART NO.	DESCRIPTION
12	5	2018378	PIN RETAINER PLATE
13	1	2020490	PIN RETAINER PLATE - 3/8" THK
14	6	2021755	SAFETY STOP END PAD
15	3	2021653	SAFETY STOP WELDMENT, 28-1/4"L
16	2	011-010	SCREW,RD HD,#10-24,PREFERRED
17	4	012-202	WASHER,LOCK,SPG,REGULAR,1/4,PREFERRED
18	4	010-000	SCREW,CAP,HEX HD,1/4-20x0.75X0.75,GR5,PREFERRED
19	4	012-210	WASHER,FLAT,ZN PLD,1/4,PREFERRED
20	12	011-211	Black-Oxide Alloy Steel Socket Head Screw, 5/16"-18 Thread Size, 5/8" Long
21	10	010-006	SCREW,CAP,HEX HD,5/16-18x1X1,GR5,PREFERRED
22	2	010-048	SCREW,CAP,HEX HD,1/2-13x1.5X1.25,GR5,PREFERRED
23	2	012-212	WASHER FLAT 1/2" BOLT SIZE ZINC PLATED
24	2	012-220	LOCKWASHER SPRING,1/2in BOLT SIZE
25	10	012-200	WASHER,LOCK,SPG,REGULAR,5/16,PREFERRED
26	2	010-086	SCREW,CAP,HEX HD,3/4-10x3.25X1.75,GR5,PREFERRED
27	2	012-214	WASHER,FLAT,3/4,PREFERRED
30	3	034-606	FITTING,06MP-06FP,STR
31	6	034-610	FITTING,06MP-06MP,90 ELBOW
32	2	071-0051	FITTING,CROSS,#6 JIC
33	1	034-689	FITTING,06FJS-06FJS,STR
37	1	025-000	JUNCTION BOX
38	1	025-001	COVER
39	2	2021855	SENSOR COVER

TILTER TABLE HOSES			
ITEM	QTY	PART NO.	DESCRIPTION
40	2	300-5005-26	HOSE, #6 HIGH PRESSURE, 2.5"L, JIC, STR-90
41	1	300-5005-27	HOSE, #6 HIGH PRESSURE, 15"L, JIC, STR-90
42	1	300-5005-28	HOSE, #6 HIGH PRESSURE, 144"L, JIC, STR-90
43	1	300-5000-38	HOSE, #6 HIGH PRESSURE, 180"L, JIC, STR-STR
44	2	300-5000-10	HOSE, #6 HIGH PRESSURE, 15"L, JIC, STR-STR

9.3 TILT TABLE

These diagrams display the field replaceable parts of the Tilt Table. Match callouts to item numbers in sections 9.1, 9.2, and 11.2.

9.4 TILT TABLE CYLINDERS

This diagram displays the tilt table cylinders and hydraulic components. Match callouts to item numbers in sections 9.1, 9.2, and 11.2.

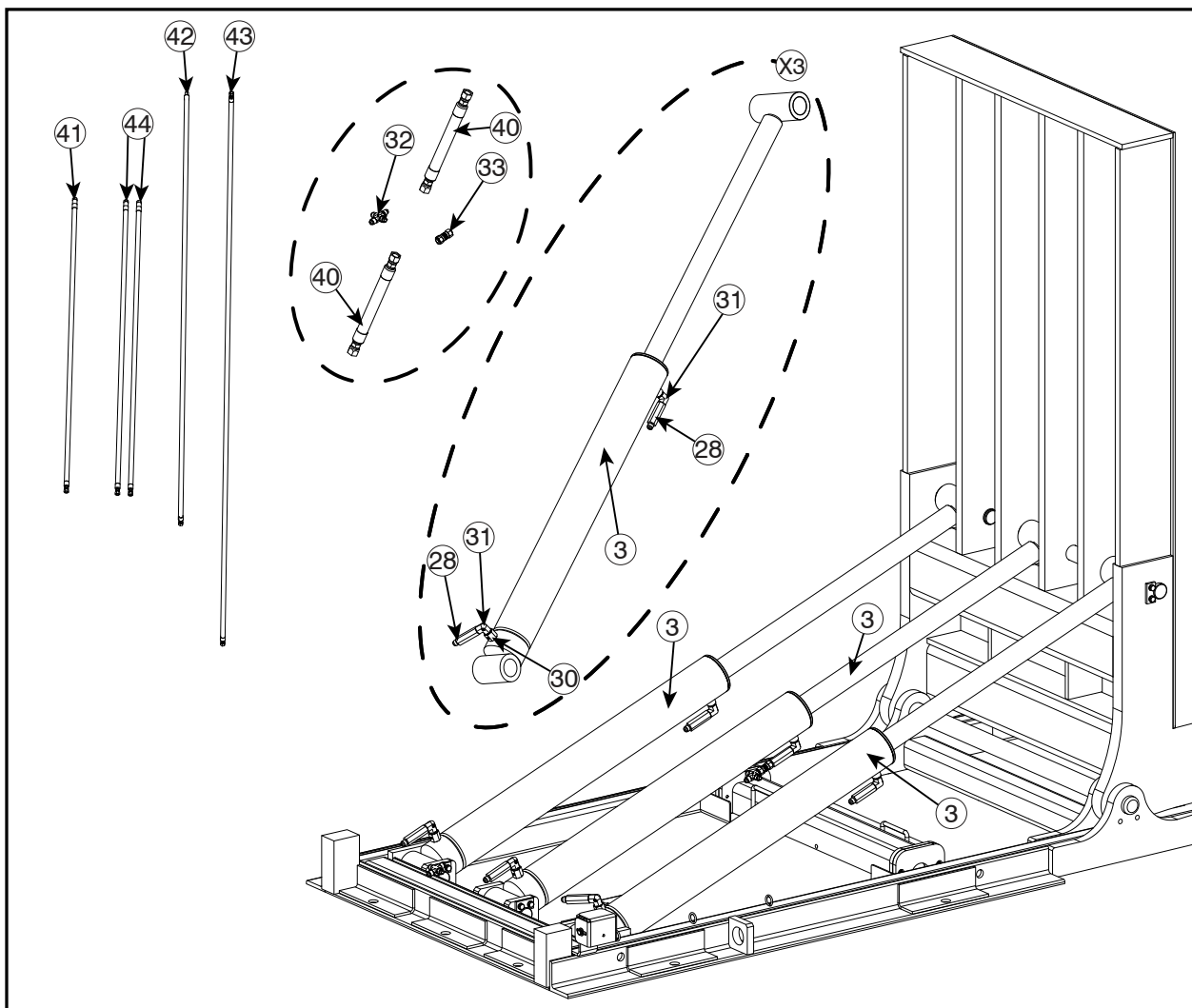

9.5 TILT TABLE PINS AND RETAINER PLATES

This diagram displays the tilt table bushings. Match callouts to item numbers in sections 9.1, 9.2, and 11.2.

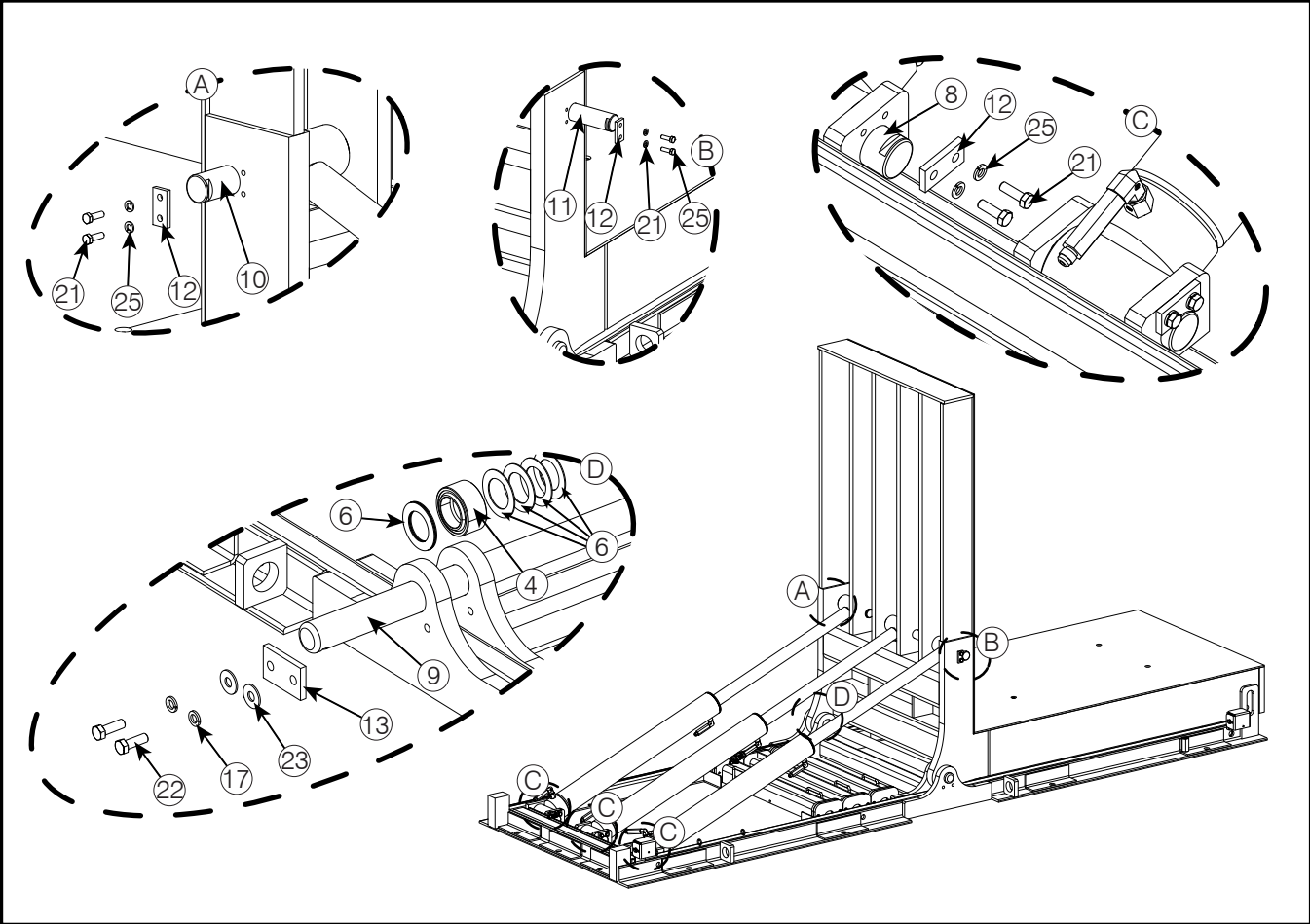

9.6 TILT TABLE BUSHING AND WASHERS

This diagram displays the tilt table bushings. Match callouts to item numbers in sections 9.1, 9.2, and 11.2.

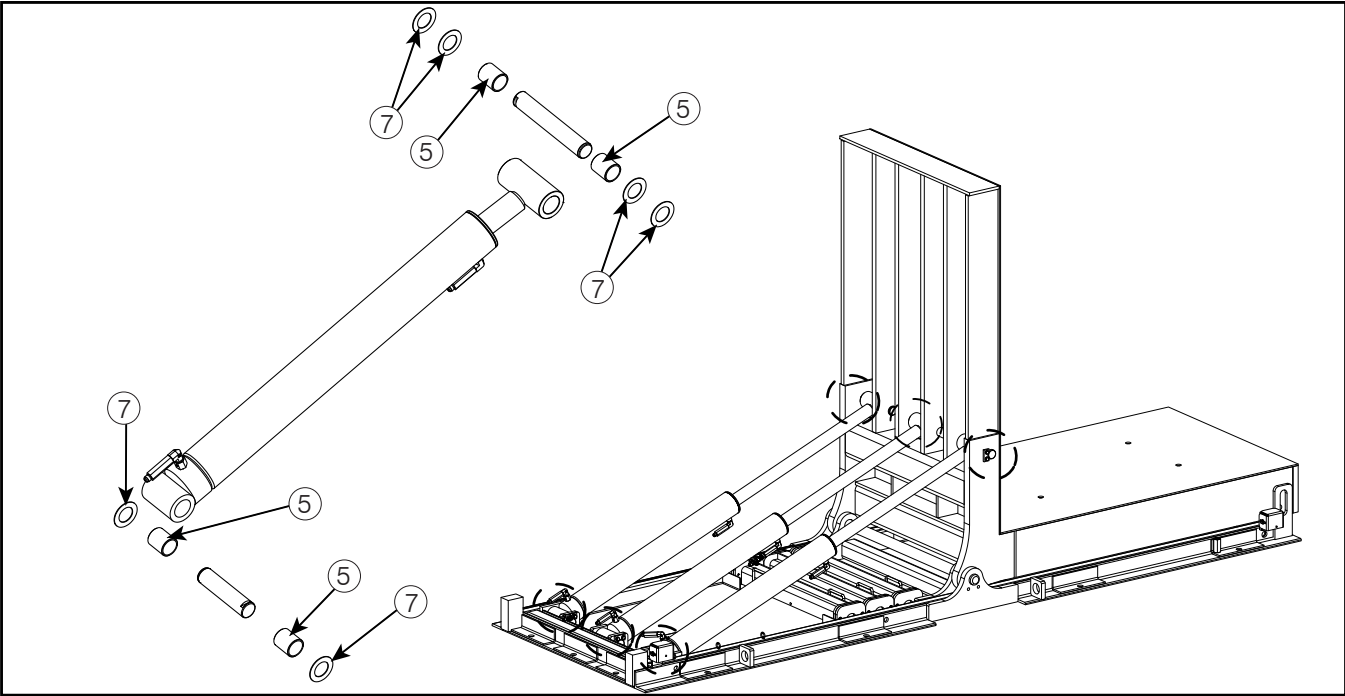

9.7 FRAME SENSORS

This diagram displays the tilt table sensors and related hardware. Match callouts to item numbers in sections 9.1, 9.2, and 11.2.

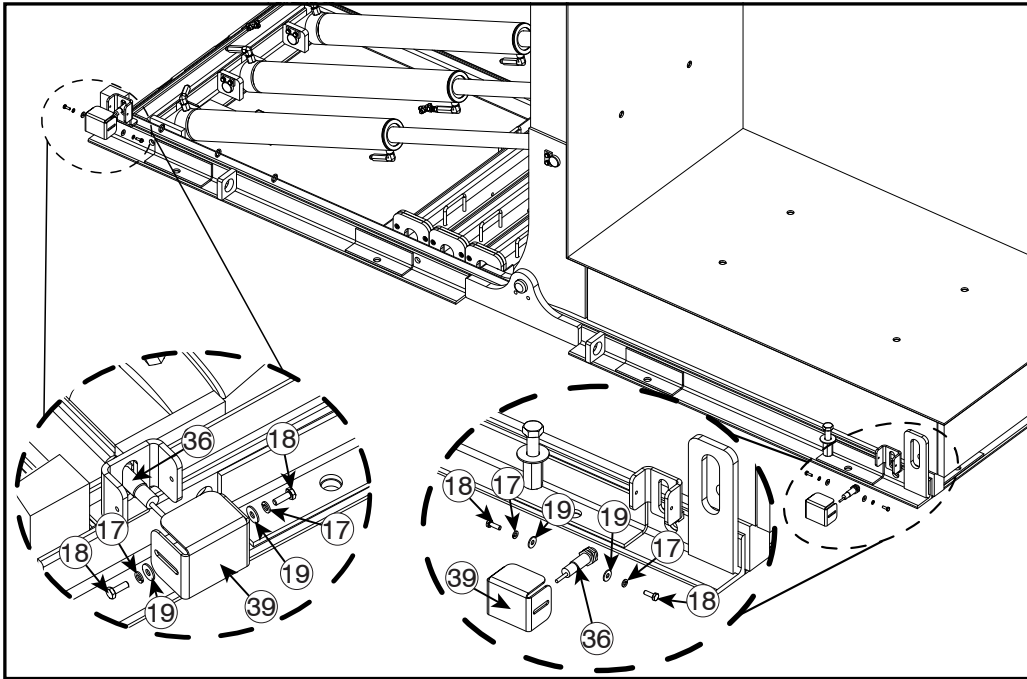

9.8 MAINTENANCE STRUTS AND SERVICE STANDS

This diagram displays the Maintenance Struts and the Service Stands. Match callouts to item numbers in sections 9.1, 9.2, and 11.2.

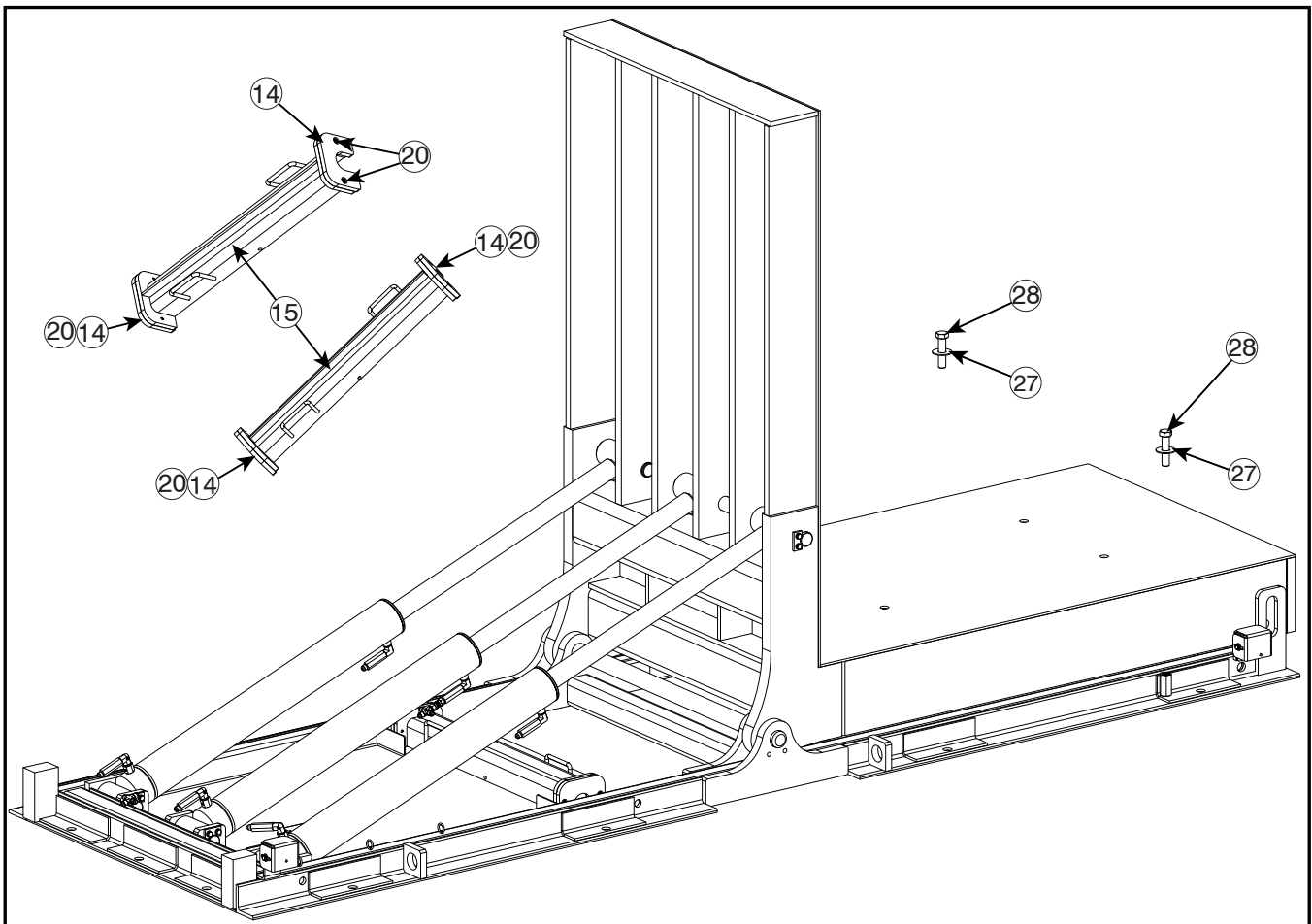

10.0 DECAL IDENTIFICATION AND LOCATION

These labels inform operators and personnel about hazardous areas on and around the tilter table.



(A)



(B)



(C)



(D)



(E)



(H)



(F)



(I)



(G)



(J)



(K)

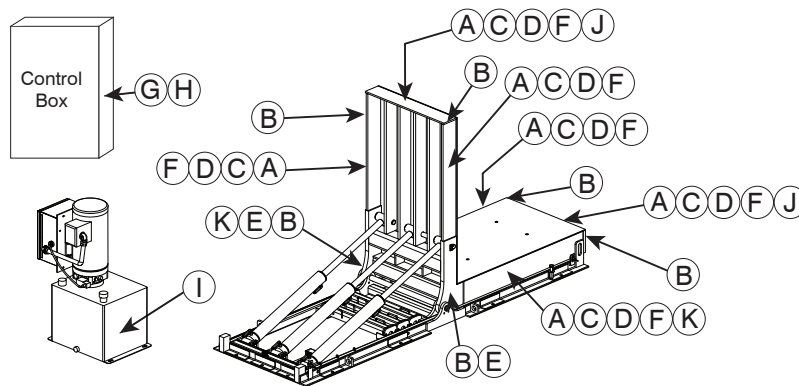

Callout	Qty	Part No.	Description
A	4	038-1101	EF ES Warns personnel to employ the Maintenance Pins before working on and under the tilt table
B	6	038-010	Safety Stripe tape to alert personnel of hazardous areas and edges (i.e. table edges, corners)
C	6	038-1188E	Warns personnel to stand clear of table and the immediate area while it is in operation
D	6	038-1160E	Warns personnel to read operating instructions before using the tilt table and warn of possible bodily injury
E	2	038-1185EFS	Nameplate to identify the tilter, serial number, and load transfer capacities
F	4	038-1161E	Warns personnel to stand clear of tilt table and the immediate area while it is in operation
G	1	114-308	Wiring diagram for facility hookup (Keep in electrical box) (Sample only shown)
H	1	038-1105EFS	Reminds personnel to lock out the electrical feeds before attempting work on the table (on exterior of electrical box)
I	1	038-1186EFS	Rated Tilt Upender Table capacity and electrics (Located on Powerpack)
J	2	038-017E	Blue Giant Logo
K	2	038-1097ES	Proposition 65 Cancer and Reproductive Harm Warning - California only

OPERATION PLACARD

The Operation Placard (Part. No. 038-545E) is to be wall mounted near the tilter controls. A duplicate is provided on the following page.



WARNING

APPLIES TO BLUE GIANT SCISSOR LIFTS

Do not operate this scissor lift without proper training and authorization.

READ AND UNDERSTAND THE FOLLOWING:

*The instructions and warnings on this placard and in the owner's manual.
The warnings on the scissor lift decals.*

Do NOT go under the scissor lift platform to clean or perform routine maintenance unless the Maintenance Strut and Service Stand are safely and securely engaged.

Prior to using the scissor lift:

- *Verify that all safety devices (guard rails, restraint chains, toe guards, and warning bells-if equipped) are in place and functioning properly.*
- *Operate the scissor lift through one complete lift / lower cycle and verify its proper operation. Inspect the scissor lift for signs of structural damage or mechanical malfunction. If damage is observed or the unit fails to operate properly, remove them from service and notify maintenance personnel immediately.*

Do NOT exceed the capacity as stated on the nameplate.

Ensure that the scissor lift serial nameplate is present and legible.

Do NOT leave the control station where it can be accidentally operated or damaged.

Be aware that lift capacity may be reduced when loads are rolled over the platform sides or edges. Refer to the nameplate for reduced capacity under these conditions.

If loads are mobile, secure them in a fixed position before operating the scissor lift.

Lift operator(s) must be present during all steps of operation.

Lift operator(s) must keep an unobstructed view of lift, any operation light/horn/bell, and other operators to ensure safe operation.

Ensure that all personnel near the scissor lift are aware that it is being operated.

Keep objects, control cables, spills, possible trip hazards, and debris away from around or under the scissor lift platform/lip and its travel path.

If the scissor lift is equipped with a hinged bridge(s), the bridge must overlap the trailer bed by a minimum of 4" (102mm) before use. Do not use the bridge if it is supported solely by the lifting chain.

Hinged lips may drop unexpectedly, keep people and objects clear of the area immediately under or near the lip.

If maintenance or service is required:

- *Only authorized service personnel shall provide maintenance / service on the lift.*
- *Follow approved lockout procedures.*
- *Do NOT work on or under the lift without properly engaging the lift's maintenance strut. Blue Giant recommends the use of a secondary means (service stand) of securing the scissor lift while performing repairs under the deck.*
- *The lift shall not be modified or altered without written approval from an authorized Blue Giant representative.*
- *Maintain records of repairs and preventive maintenance reports.*

11.0 EQUIPMENT COMPONENT ILLUSTRATIONS

This section displays the various hardware components.

11.1 COMPONENTS AS SHIPPED CHECKLIST

This section displays the shipped hardware components.

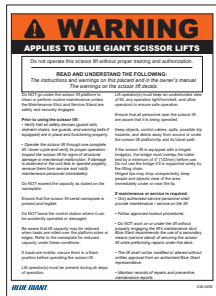

(B)

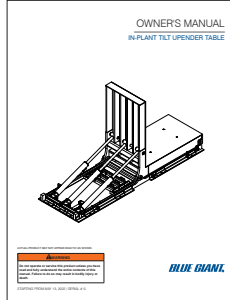

(C)

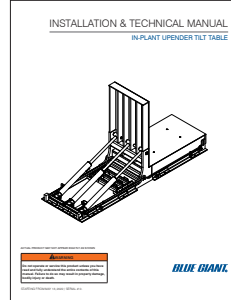

(D)

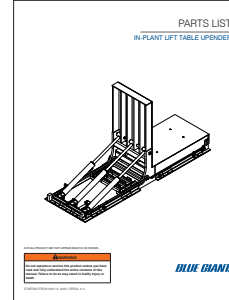

(E)

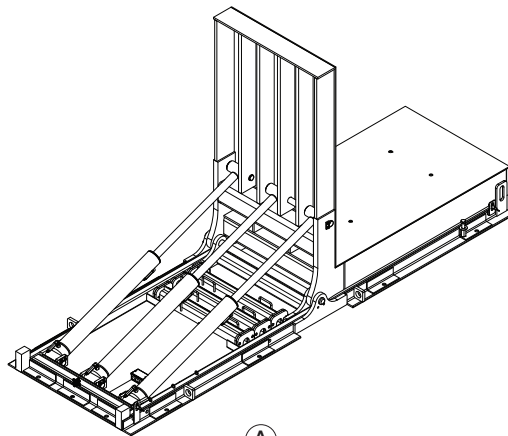

(A)

✓	CALLOUT	QTY.	PART NO.	DESCRIPTION	APPROX. WEIGHT	
	A	1	Model Dependent	Tilt Upender Table	Varies by Model	
	B	1	033-892	Powerpack 5HP 460V/3/60 2.4GPM	Varies by Model	
	C	1	038-545E	Operation/Warning Placard	—	—
	D	1	038-343EI	Installation Manual	—	—
	E	1	038-343E	Owner's Manual	—	—
	F	1	038-343EPL	Parts List	—	—

11.2 TILT UPENDER TABLE MECHANICAL ASSEMBLY

This diagram shows a detailed view of the Tilt Upender Table assembly.

NOTE: Actual product may not appear exactly as shown.

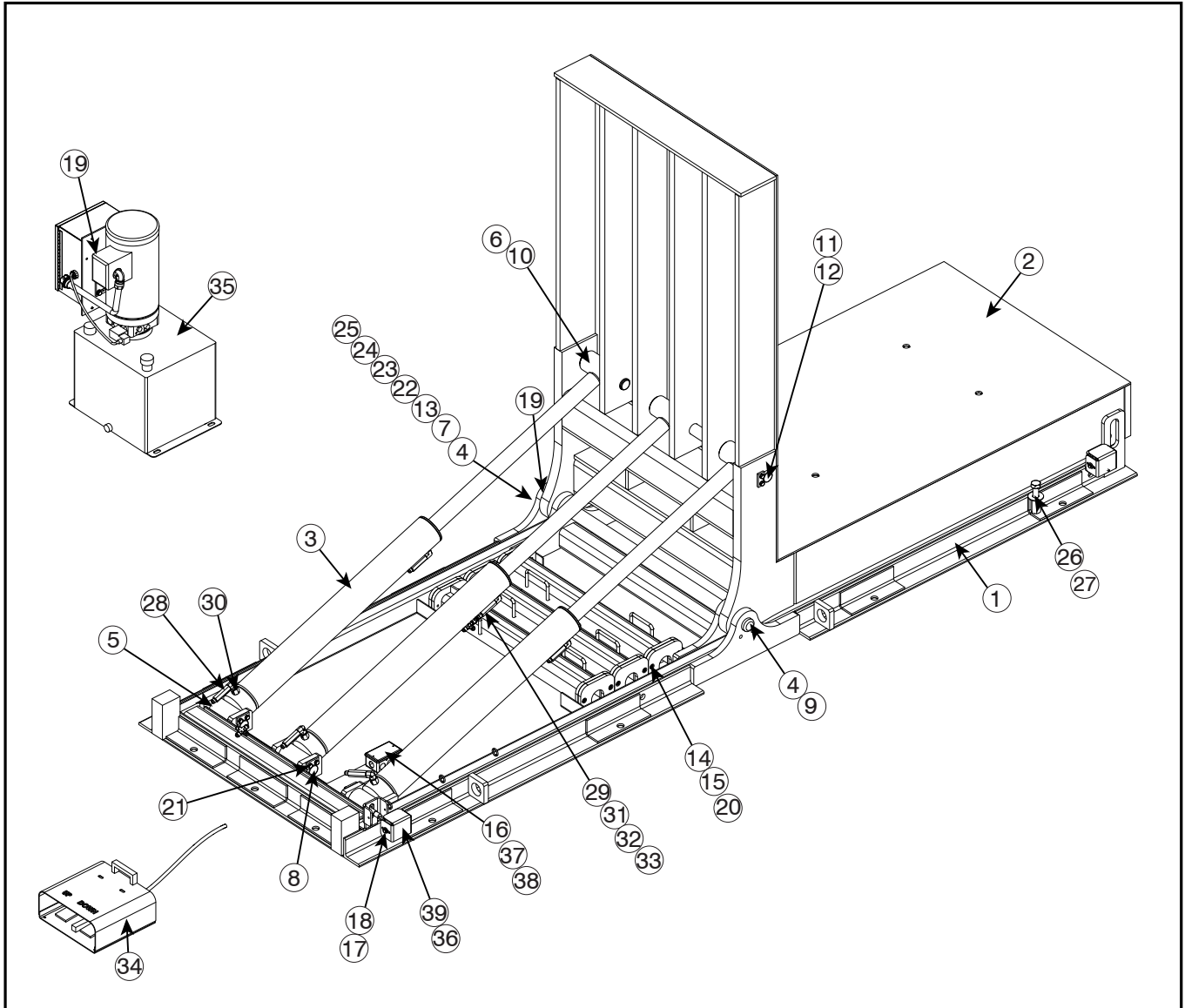

ITEM	QTY	PART NO.	DESCRIPTION
1	1	2021466	BASE FRAME UPENDER, 42-1/2"X133-1/4"
2	1	2021417	UPENDER PLATFORM WELDMENT 36" X 60"
3	3	780-144-294-DA	CYLINDER ASSY (3-1/2"DIA), ED/FS/DS [29 1/2" STROKE], D/A
4	2	018-125	SPHERICAL BEARING, 1.75" ID, MAINT FREE
5	12	018-099	BUSHING, PLASTIC, 1 1/2in ID x 2in L
6	16	105-894	THRUST WASHER FLAT 1.75"ID X 2.75"OD X 0.0585"THK IGUS GTI-2844-01
7	14	105-884	THRUST WASHER FLAT 1-1/2"ID X 2-1/2"OD X 0.0585"THK IGUS GTI-2440-01
8	3	2021512	PIN, 1 1/2" OD X 6.375" L SUPERIOR SHAFTING
9	1	2021453	PIN, 1 3/4" OD X 40" L SUPERIOR SHAFTING
10	1	2021459	PIN, 1 1/2" OD X 9.375" L SUPERIOR SHAFTING
11	1	2021511	PIN, 1 1/2" OD X 23" L SUPERIOR SHAFTING
12	5	2018378	PIN RETAINER PLATE
13	1	2020490	PIN RETAINER PLATE - 3/8" THK
14	6	2021755	SAFETY STOP END PAD
15	3	2021653	SAFETY STOP WELDMENT, 28-1/4"L
16	2	011-010	SCREW, RD HD, #10-24, PREFERRED
17	4	012-202	WASHER, LOCK, SPG, REGULAR, 1/4, PREFERRED
18	4	010-000	SCREW, CAP, HEX HD, 1/4-20x0.75X0.75, GR5, PREFERRED
19	4	012-210	WASHER, FLAT, ZN PLD, 1/4, PREFERRED
20	12	011-211	Black-Oxide Alloy Steel Socket Head Screw, 5/16"-18 Thread Size, 5/8" Long
21	10	010-006	SCREW, CAP, HEX HD, 5/16-18x1X1, GR5, PREFERRED
22	2	010-048	SCREW, CAP, HEX HD, 1/2-13x1.5X1.25, GR5, PREFERRED
23	2	012-212	WASHER FLAT 1/2" BOLT SIZE ZINC PLATED
24	2	012-220	LOCKWASHER, SPRING, 1/2
25	10	012-200	WASHER, LOCK, SPG, REGULAR, 5/16, PREFERRED

ITEM	QTY	PART NO.	DESCRIPTION
26	2	010-086	SCREW, CAP, HEX HD, 3/4-10x3.25X1.75, GR5, PREFERRED
27	2	012-214	WASHER, FLAT, 3/4, PREFERRED
28	3	033-538	EXCESS FLOW PROTECTOR 2 GPM, 6FNPT-6MJIC
29	3	033-533	EXCESS FLOW PROTECTOR 1.75 GPM, 6FNPT-6MJIC
30	3	034-606	FITTING, 06MP-06FP, STR
31	6	034-610	FITTING, 06MP-06MP, 90 ELBOW
32	2	071-0051	FITTING, CROSS, #6 JIC
33	1	034-689	FITTING, 06FJS-06FJS, STR
34	1	026-224	FOOT SWITCH
35	1	033-892	POWERPACK 5HP 208-230 460V/3/60 INT. VER 8GAL
36	2	028-209	PROXIMITY SENSOR - XS618B1MBL2-N/C
37	1	025-000	JUNCTION BOX
38	1	025-001	COVER
39	2	2021855	SENSOR COVER

11.3 TILT TABLE MECHANICAL ASSEMBLY

This diagram displays the tilt table mechanical components with manual section numbers as callouts. For any component or area of interest, refer to the manual sections displayed as Callouts. For example, see section "9.4 TILT TABLE CYLINDERS" on page 32 for a view of the cylinders under the Tilt Table.

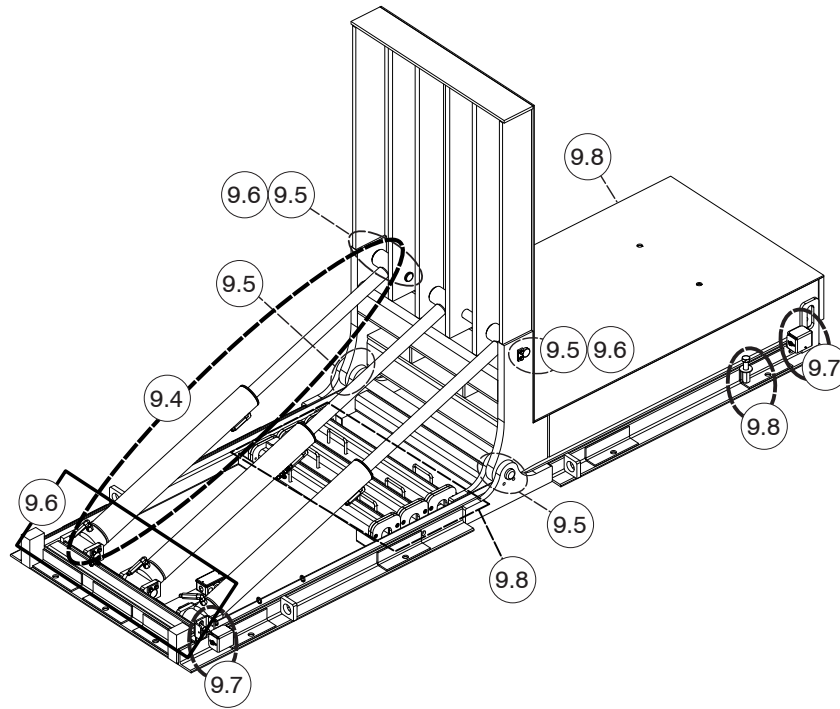

12.0 POWERPACK PART IDENTIFICATION

The assembly and parts of the Powerpack are listed below for easy reference.

NOTE: Refer to the electrical drawings for specific wiring requirements

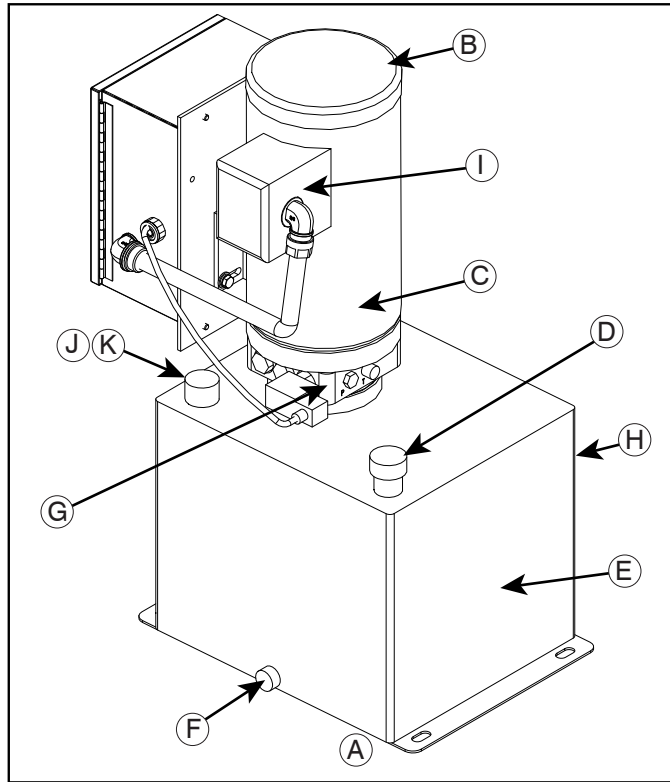

Tilt Upender Table POWERPACK PART NUMBER VARIES ON MODEL			
ITEM	QTY	PART NO.	DESCRIPTION
A	1	Varies on Model	Powerpack 5HP 460V/3/60 3.4GPM
B	1	033-370	Motor
C	1	033-371	Pump (not shown)
D	1	035-315	Filter/Breather
E	1	035-312	Tank/Reservoir
F	1	035-313	Drain (not shown)
G	1	—	Tilt Manifold
H	1	035-314	Sight Glass Oil Level
I	1	—	Junction Box
J	1	033-352	Return Line Filter
K	1	033-353	Replacement Element for Return Line Filter
L	1	033-367	Suction Strainer (not shown)

12.1 HYDRAULIC SCHEMATIC

This diagram illustrates the Powerpack hydraulic circuits.

SUPPLY VOLTAGE: 460/3/60
 CONTROL VOLTAGE 24VAC
 INTERMITTENT POWERPACK

LOGIC TABLE AS PER SCHEMATIC

ACTION	SV1	SV2	MOTOR
RUN/UNLOAD			
TILT UP	X		X
TILT DOWN		X	X

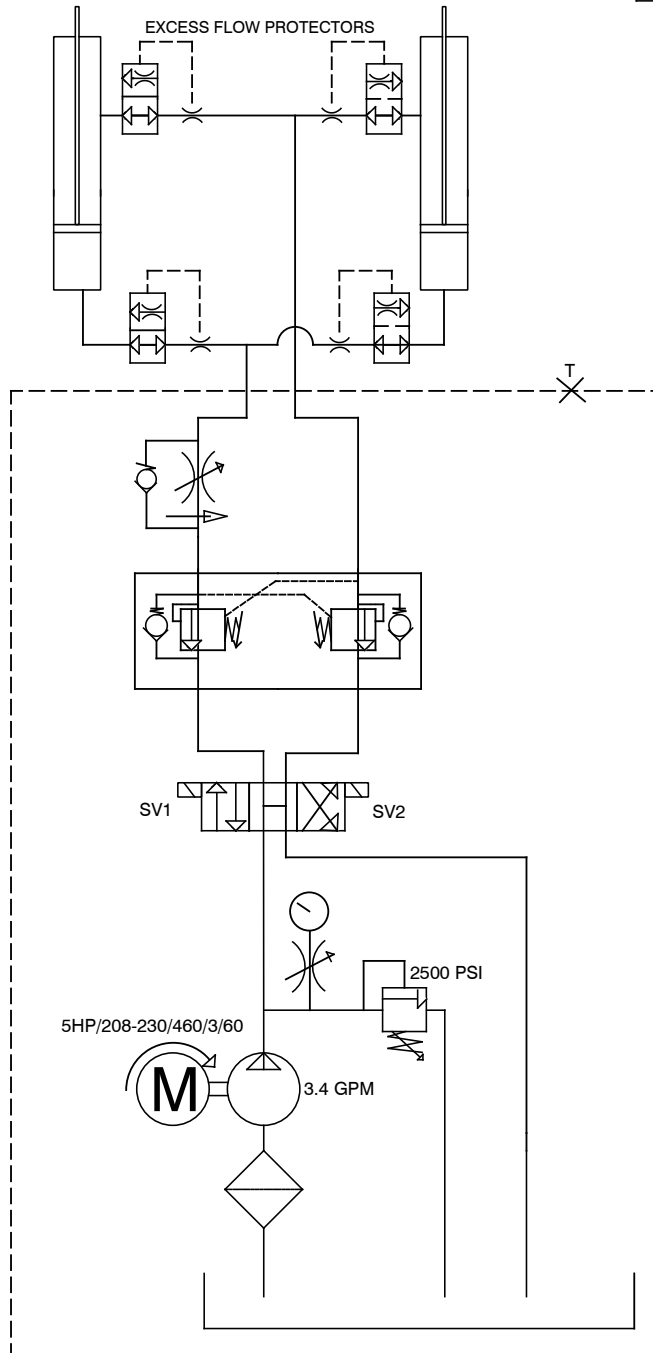

BLUE GIANT®

TITLE: 033-892
 UPENDER HYDRAULIC SCHEMATIC

MODEL:
 1K2D37K1(3C3)2530CVGSLP-2500V

CUSTOMER:

ORDER:

13.0 TROUBLESHOOTING

Use this section to help diagnose issues if the In-plant Tilt Table is not operating as specified.

 DANGER

- Failure to properly secure the tilt deck prior to working underneath it may result in bodily injury, or death.
- Engage the Maintenance Pins and Service Stand before working. If the Pins and Service Stand cannot be successfully engaged, contact your Blue Giant Dealer.

 WARNING

- Do not attempt to install, make repairs, or adjustments. Only a trained and authorized service technician should perform the installation process, make repairs, or make adjustments. Contact your Blue Giant Dealer for assistance.
- Do not service this equipment until you have read and understood all of the safety information and instructions contained herein. Failure to adhere to recommended safety practices in this manual and on the tilt equipment warning labels could result in death or serious injury.
- Do not conduct maintenance or repairs until adequate barriers have been placed to keep personnel, warehouse, and vehicle traffic away from the work area.
- Before doing any electrical work, verify that the power is disconnected and properly tagged or locked out, in accordance with OSHA regulations and approved electrical codes.
- When conducting maintenance, use only Blue Giant approved lubricants. Improper lubrication or adjustments may cause operational problems.

The following description of operating principles is intended as a guide when trouble shooting and making adjustments or repairs. If no fault can be found and equipment fails to operate properly, contact your Blue Giant Dealer.

- Pressing the **UP** foot pedal energizes the pump which supplies fluid under pressure to cylinder for tilt deck. A check valve (inside pump) prevents any back flow of oil through pump when it is shut off.
- Pressing the **DOWN** foot pedal opens the solenoid lowering valve which allows fluid from cylinder to return to reservoir. Optional: the lowering speed controlled by a load lowering valve. Otherwise, the lowering speed is factory set for safe lowering and normally requires no further adjustment.
- A limit switch is used to control upward travel, it is electrically connected in series with the **UP** foot pedal switch on a single switch station.

PROBLEM	PROBLEM CAUSED
Tilt table will not raise.	<p>Foreign material lodged between side of tilt table and other components. Remove and discard foreign material as required.</p> <p>Equipment or goods parked on tilt deck. Remove and test operate the tilter. Verify tilter capacity before resuming.</p> <p>Low hydraulic oil fluid in power unit. Damaged hose or other oil leak, repair and refill with approved hydraulic oil as required.</p> <p>Incorrect motor rotation: three phase power supply only. Contact qualified personnel to correct.</p> <p>Fuse and / or overload blown. Check fuse and / or overload reset.</p> <p>Filter may have blockages. Clean or replace suction filter.</p> <p>Valve may have blockages. Replace / repair if necessary.</p> <p>Pump not running at correct system pressure. Replace / repair if necessary.</p> <p>UP foot pedal/open circuit. Check for open circuit in UP limit set improperly contact block or broken wire in harness.</p> <p>Wrong voltage. Check line voltage to nameplate voltage.</p> <p>Motor connected to high voltage connection on lower voltage feed. Check motor connection to nameplate.</p> <p>Control fuse blown. Replace.</p> <p>Interlock devices. Check all switches.</p> <p>Shipping bolts not removed. Remove.</p> <p>Hydraulic hose pinched. Check hose.</p>
Tilt table does not maintain steady height.	<p>Oil leak may be present. Repair leak.</p> <p>Motor check valve is defective. Replace, if necessary.</p> <p>Down solenoid valve is defective. Replace, if necessary.</p>
Tilt table locked in "UP" position. When DOWN foot pedal is pushed, a click can be heard.	<p>Velocity fuse locked. Contact your Blue Giant Dealer.</p> <p>If equipped, lowering speed valve closed. Open to set proper lowering speed.</p>
Tilt table will not lower. No clicking sound heard when a button is pressed.	<p>DOWN foot pedal broken / open circuit. Check for open circuit in contact block, broken wire in harness, safety trip bar circuit (if equipped). Scissor leg bushings seized.</p> <p>Lowering valve defective. Replace.</p>
Tilt table raises slowly.	<p>Pressure relief bypassing. Foreign material lodged between ball and seat. Contact your Blue Giant Dealer.</p> <p>Faulty Power Pack. Replace Power Pack.</p> <p>Weight overload. Remove weight to until load matches nameplate weight capacity rating.</p>

IN-PLANT TILT UPENDER TABLE — OWNER'S MANUAL

PROBLEM	PROBLEM CAUSED
Tilt table will not begin to raise immediately when motor begins to run. Usually occurs only after the deck cylinder hose has been replaced with a new hose that was not pre-filled with oil.	Air is trapped in the tilting cylinder(s). Bleed off the air.
Tilt table will not raise when UP foot pedal is operated. Motor does not attempt to run, no sound is heard from motor/Powerpack/control box	No power supply to control box. Trace electrical feed. Thermal overload tripped open. Reset. Faulty control box component (e.g. fuse, foot pedal, contactor, transformer). Repair/Replace.
Tilt table will not raise when foot pedal is operated. Motor attempts to run, but power supply breaker switch trips to off position	Power supply circuit is overloaded by other equipment or components being used on a branch circuit controlled by the same breaker switch. The power supply line circuit must be upgraded to meet the requirements of the power unit. Wrong size feed supplied to Powerpack.
Tilt table lowering speed is too slow or too fast.	Deck speed not set correctly. Lowering speed adjustment required, if equipped.
Tilt table raises partially and stops. Motor continues to run and power unit makes more noise than normal	Oil level in reservoir is low. Fill oil reservoir with approved hydraulic oil.
Tilt table raises more slowly than normal and level in reservoir is normal	Pilot operated to close Check Valve will not close. Replace. Faulty Powerpack. Replace.
Tilt table will not lower from fully raised position.	The fail-safe velocity fuse located at the bottom of the deck cylinder is in the locked or closed position. Replace.
Tilt table does not extend fully. Oil level in reservoir is not low.	Tilt plate bent causing hinge to bind. Replace. Foreign material lodged in the tilter hinge area. Clean out material safely.
Tilt table lowers slowly in normal temperatures and very slowly in extremely cold weather. Deck lowering speed is correct.	Consider the optional Oil Heater or using Arctic Oil. Opening the needle valve will cause the tilter to lower too quickly, which will in turn cause the fail-safe velocity fuse to lock. The tilter lowers by gravity and must pivot freely on its full length hinge. Speed control set too low. Adjust as needed.

14.0 OPTIONAL EQUIPMENT

Components may be available as additional options for the Tilt Upender Table. Refer to site drawings for specifics.

14.1 SAFETY FEATURES

These features may be provided for greater personnel protection and operating awareness. Refer to site drawings for specifics.

- Keyed lock and E-Stop push button options on push button controls. Keyed lock provides greater security and access control. E-Stop provides protection for personnel and material.
- Factory set up travel limit switch limits the maximum vertical elevation of the tilter.
- Accordion safety skirting acts as a barrier to keep under the tilter clean and provide personnel awareness.
- Electric trip bars that stops the tilter if any obstructions are sensed during lowering.

BLUE GIANT[®]
BLUE GIANT EQUIPMENT CORPORATION

Corporate 410 Admiral Blvd
Mississauga, ON, Canada L5T 2N6
t 905.457.3900 f 905.457.2313

USA 6350 Burnt Poplar Road
Greensboro, NC 27409
www.bluegiant.com