

OPERATOR'S MANUAL

EPJ-40 ELECTRIC PALLET TRUCK



WARNING

Do not operate or service this product unless you have read and fully understand the entire contents of this manual. Failure to do so may result in property damage, bodily injury or death.

BLUE GIANT[®]

ISSUE DATE: MAY 5, 2020 REV.0 (PART # 038-928EO)



WARNING

DO NOT OPERATE THIS TRUCK UNLESS YOU HAVE BEEN TRAINED AND AUTHORIZED TO DO SO, AND HAVE READ ALL WARNINGS AND INSTRUCTIONS IN OPERATORS MANUAL AND ON THIS TRUCK.

DO NOT OPERATE THIS TRUCK UNTIL YOU HAVE CHECKED ITS CONDITION. GIVE SPECIAL ATTENTION TO TIRES, HORN, BATTERY, CONTROLLER, LIFT SYSTEM, BRAKES, STEERING MECHANISM, GUARDS AND SAFETY DEVICES.

OPERATE TRUCK ONLY FROM DESIGNATED OPERATING POSITION. WEAR FOOT PROTECTION. DO NOT CARRY PASSENGERS.

OBSERVE APPLICABLE TRAFFIC REGULATIONS. YIELD RIGHT OF WAY TO PEDESTRIANS. SLOW DOWN AND SOUND HORN AT CROSS AISLES AND WHEREVER VISION IS OBSTRUCTED.

START, STOP, TRAVEL, STEER AND BRAKE SMOOTHLY. SLOW DOWN FOR TURNS AND ON UNEVEN OR SLIPPERY SURFACES THAT COULD CAUSE TRUCK TO SLIDE OR OVERTURN. USE SPECIAL CARE WHEN TRAVELING WITHOUT LOAD AS THE RISK OF OVERTURN MAY BE GREATER. ALWAYS LOOK IN DIRECTION OF TRAVEL. KEEP A CLEAR VIEW, AND WHEN LOAD INTERFERES WITH VISIBILITY TRAVEL WITH LOAD OR LIFTING MECHANISM TRAILING.

USE SPECIAL CARE WHEN OPERATING ON RAMPS - TRAVEL SLOWLY, AND DO NOT ANGLE OR TURN. TRAVEL WITH LIFTING MECHANISM DOWNHILL.

DO NOT OVERLOAD TRUCK. CHECK CAPACITY PLATE FOR LOAD WEIGHT AND LOAD CENTER INFORMATION.

DO NOT HANDLE LOADS WHICH ARE HIGHER THAN THE LOAD BACKREST OR LOAD BACKREST EXTENSION UNLESS LOAD IS SECURED SO THAT NO PART OF IT COULD FALL BACKWARD. BEFORE LIFTING, BE SURE LOAD IS CENTERED, FORKS ARE COMPLETELY UNDER LOAD, AND LOAD IS AS FAR BACK AS POSSIBLE AGAINST LOAD BACKREST.

WHEN LEAVING TRUCK, NEUTRALIZE TRAVEL CONTROL. FULLY LOWER LIFTING MECHANISM AND SET BRAKE. WHEN LEAVING TRUCK UNATTENDED, ALSO SHUT OFF POWER.

FOREWORD

As a lift truck operator, you are responsible for a machine that is useful, powerful, and can be hazardous if not operated as described. Your Blue Giant truck may weigh more than some cars, depending on the model. Observing and practicing the safety warnings in this manual cannot be overemphasized. Just knowing the warnings, however, is no substitute for **common sense**. Using your common sense will, in almost all cases, prevent accidents. Think of the truck as your own. In this way you will learn its capabilities and limitations.

This manual is intended to remain with the truck at all times as a handy

reference guide to operation. Detailed maintenance procedures are found in the parts and service manual for the specific truck model, and are to be performed only by a qualified technician. For further information on obtaining a complete parts and service manual, see [page 21](#) of this manual.

The operator who knows his truck will learn to spot problems as they develop. This is accomplished by performing the Daily Checks and reporting any problems to the designated authority.

TABLE OF CONTENTS

SAFETY SYMBOLS	2
GENERAL DESCRIPTION	2
NAME PLATE AND WARNING DECAL	2
LOAD CAPACITY	4
BEFORE OPERATION	5
Optional Features	8
INSTRUMENTS AND CONTROLS	7
Optional Features	8
OPERATION	9
Forward and Reverse Travel and Speed Control	9
Steering	9
Stopping	10
Parking	10
Battery Charging	11
Load Handling	11
Moving a Disabled Truck	11
NOTICE - OBTAINING A PARTS AND SERVICE MANUAL	21

SAFETY SYMBOLS

WARNING and **CAUTIONS** are both signal words intended to alert the viewer to the existence and relative degree of a hazard. They are both preceded by a safety alert symbol consisting of an exclamation mark enclosed by a triangle.



A **Warning** indicates a hazard which could result in injury or death if proper precautions are not taken.

A **Caution** indicates a reminder of routine safety practices.

A prohibition slash (circle with diagonal slash through it) indicates a procedure or action that should **not** be performed under any circumstances, as both personal injury and/or damage to equipment will result.



GENERAL DESCRIPTION

Blue Giant Pallet trucks lift and transport loads on rigid forks.

Control for steering, braking, forward and reverse travel, horn, lift, lower and speed control are all located on the control handle.

Trucks in this series may vary in load capacity, battery arrangement, and instrumentation, depending on model and options.

NAME PLATE AND WARNING DECAL

Name plate and warning decal locations may vary between models, but they are always near the steering arm within sight of the operator.

If the name plate or warning decal are lost or damaged they should be replaced immediately. Have your supervisor or the designated authority contact Blue Giant Authorized Dealer for replacement.

The name plate shows the model number; serial number; truck type; battery type, voltage and minimum weight. It also contains information on the load capacity and load center. The warning decal contains warnings which also appear, with illustrations, in the Operating Precautions section of this manual.

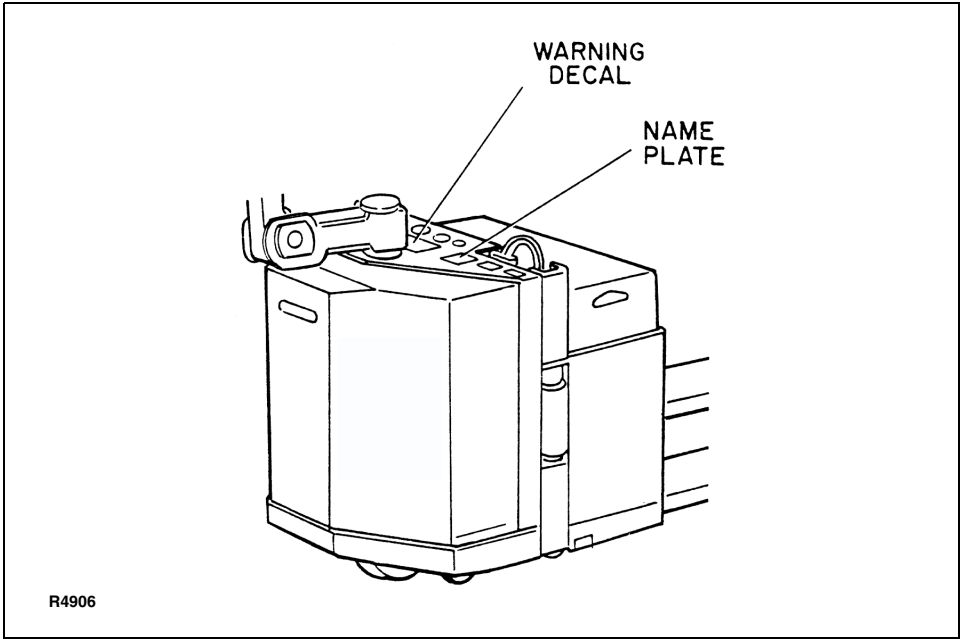

Name Plate and Warning Decal Locations - Typical



WARNING:

This truck is equipped with a battery. Read and heed the warning decal located near the battery. An example is shown here:

<p>BATTERY HAZARD</p>	<p>! DANGER</p> <p>EXPLOSIVE/POISON/CAUSTIC NO SPARKS, FLAMES, SMOKING BATTERY ACID can cause blindness and severe burns</p> <p>SHIELD EYES, AVOID SKIN CONTACT</p> <p>IF SPLASHED flush immediately with water, get medical help fast.</p> <p>Do not service battery while on charge. Do not connect or disconnect battery from charger while charger is on.</p> <p>Only qualified and experienced personnel should perform maintenance and repair on batteries. Use caution while servicing or removing battery. (Refer to Battery Safety Sheet).</p>
------------------------------	--

LOAD CAPACITY

Do not overload truck. Check capacity plate for load weight and load center information.

The load capacity depends on the load center. The load maximum capacity listed on the capacity plate assumes a uniform load whose center is at 1/2 the length of the fork and centered between the forks. The maximum load capacity is reduced when

the load center exceeds 1/2 the length of the forks or is not centered between the forks. The fork length and wheel-base must be adequate for the skid or bin to be handled.

Note that a truck undergoing speed changes is less stable than a standing truck. If you are not sure that the truck can lift a certain load, consult your supervisor or the designated authority.

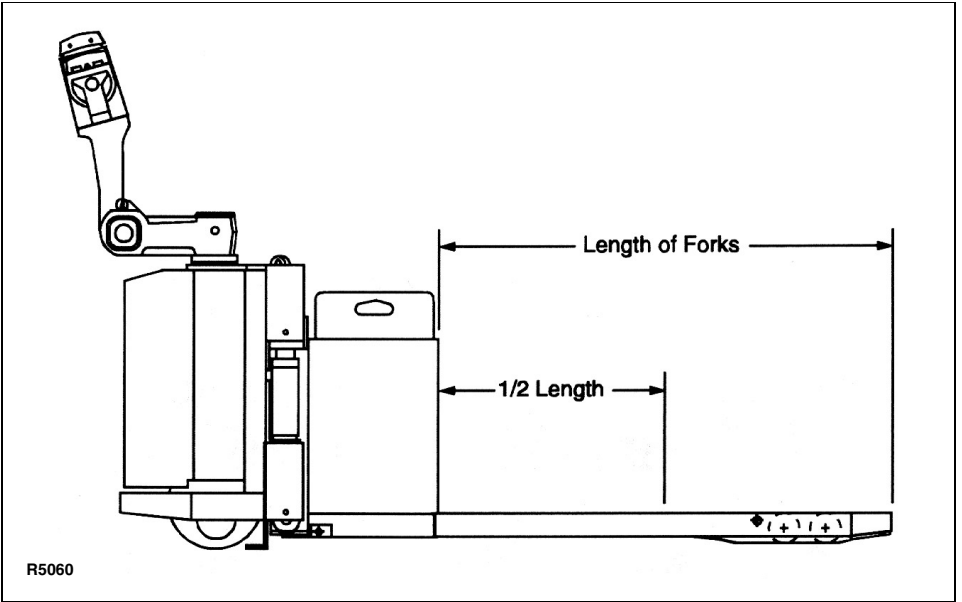

Load Center

BEFORE OPERATION

The table on [page 6](#) covers important inspection points on trucks which should be checked prior to operation. Depending on use, some trucks may require additional checks.

The illustration below shows a sample format for a Operator Checklist, which can be modified as necessary to fit your operation.



WARNING:

Periodic maintenance of this truck by a QUALIFIED TECHNICIAN is required.



WARNING:

A QUALIFIED SERVICE TECHNICIAN should check the

truck monthly for proper lubrication, proper fluid levels, brake maintenance, motor maintenance and other areas specified in the parts and service manual maintenance section.



WARNING:

If the truck is found to be unsafe and in need of repair, or contributes to an unsafe condition, report it immediately to the designated authority. Do not operate it until it has been restored to a safe operating condition. Do not make any unauthorized repairs or adjustments. All service must be performed by a qualified maintenance technician.

Electric Truck
Daily Operator Check-Off List

Date _____ Operator _____
 Truck No. _____ Model No. _____
 Dept. _____ Shift _____
 Hour Meter Reading—Drive _____ Hoist _____

Check	O.K. (✓)	Need Maintenance
Tires		
Load Wheels		
Horn		
Lift—Lower Control		
Attachment Operation		
Forward & Reverse Controls		
Steering		
Electrical Brakes		
Hydraulic Leaks, Cylinders, Valves, Hoses, Etc.		

R6235

Sample of Operator Check List

Operator Checks

ITEM	PROCEDURE
Transmission and hydraulic systems	Check for signs of fluid leakage.
Forks	Check for cracks and damage.
Guards and load backrest	Check that safety guards are properly secured and not damaged.
Safety signs	Check that warning labels, nameplate, etc., are in good condition and legible.
Horn	Check that horn sounds when operated.
Steering	Check for binding or looseness in steering arm when steering.
Travel controls	Check that speed controls on control handle operate in all speed ranges in forward and reverse and that belly button switch functions.
Wheels	Check drive wheel for cracks or damage. Move truck to check load wheels for freedom of rotation.
Hydraulic controls	Check operation of lift and lower, and tilt to their maximum positions.
Brakes	Check that brakes actuate when steering arm is raised to upright position, and when lowered to horizontal position.
Deadman/Parking brake	Check that steering arm raises to upright position when released and brake applies.
Battery disconnect	Check that battery can be disconnected and reconnected. Check for connector damage.
High speed limit switch	Allow for enough space to operate truck in high speed. Disengage third speed using the high speed cut-out switch, then test drive truck to check if high speed is cut out.

INSTRUMENTS AND CONTROLS

The steering arm and control handle provide controls for steering, forward and reverse speed control, braking, raising and lowering the forks, and horn. Control handles on some models have the high speed cut-out switch. Control handles on all models have the high speed cut-out switch. Control handles on all models have a “belly-button” reversing switch which reverses the direction of the truck upon contact with the operator.

Detailed operating instructions are in the Operation section of this manual.

A battery disconnect is mounted near the steering arm. Pulling the disconnect removes all power from truck circuits in the event of an emergency.

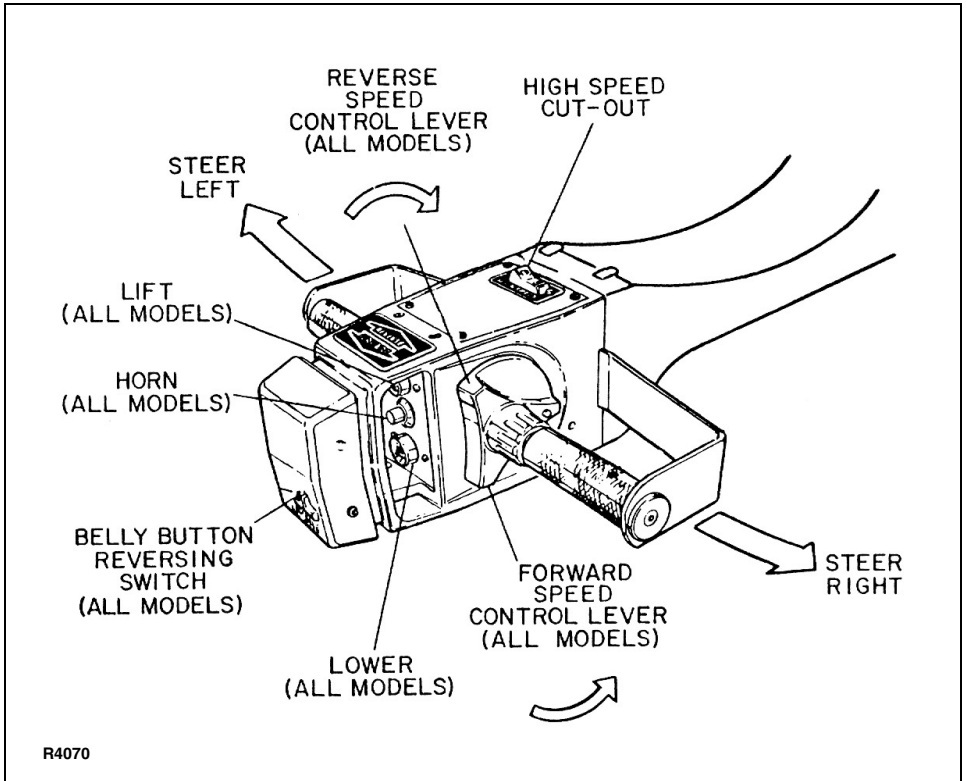

Control Handle

Walkie/Rider Pallet Trucks have a grab handle which also contains lift, lower and horn controls.

Optional Features

The optional battery capacity indicator, hour meter and keyswitch mount on the panel near the control handle. The battery capacity indicator moni-

tors the battery discharge rate to indicate the remaining battery capacity. The hour meter records the accumulated hours that electrical energy is being drawn from the battery to run the pump and drive motors. The keyswitch provides added security to the truck, preventing unauthorized personnel from operating the machine.

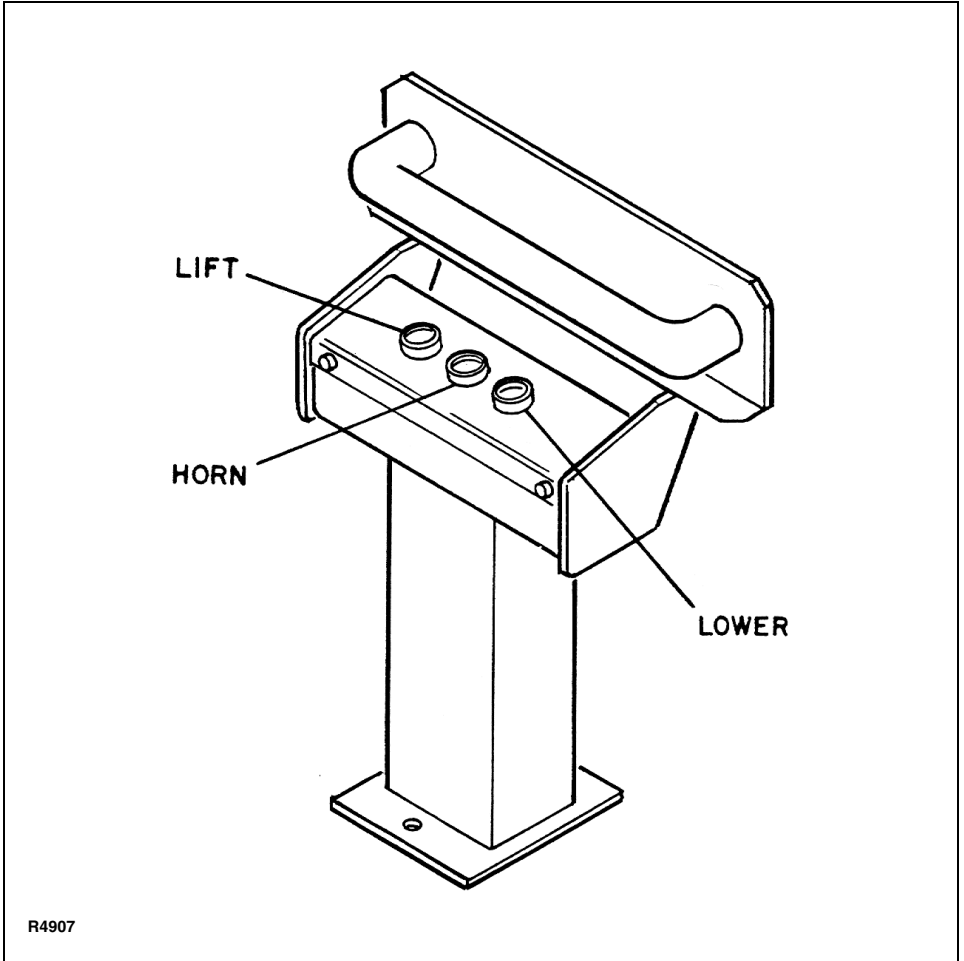

Grab Handle

OPERATION

Forward and Reverse Travel and Speed Control

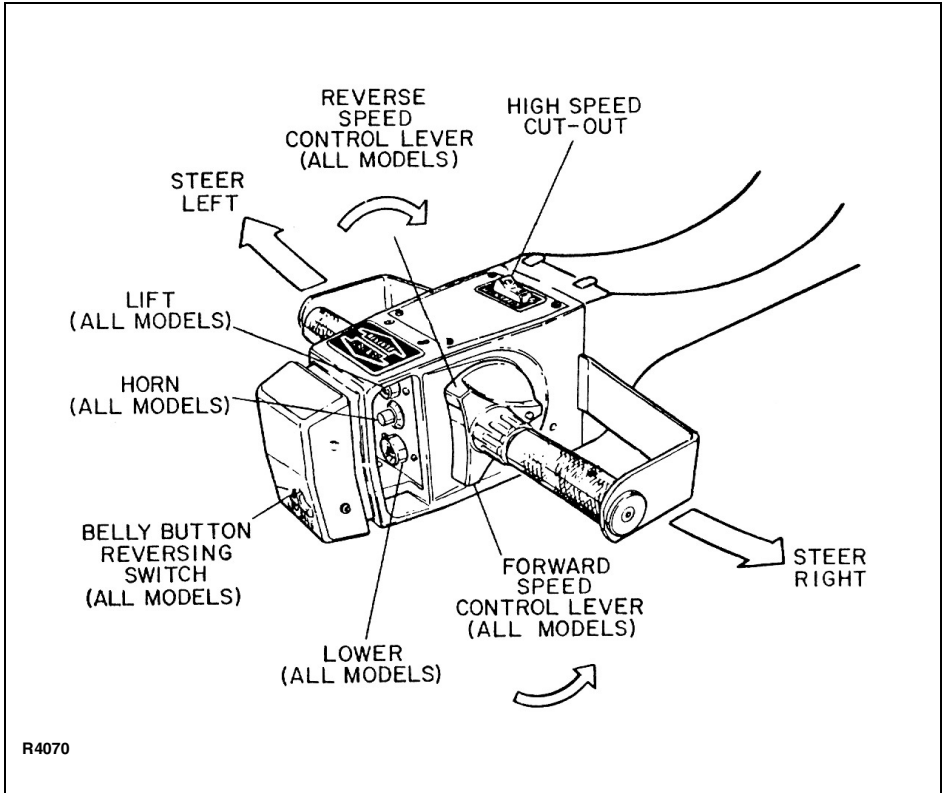

Control Handle

All directional and speed controls are located on the control handle.

Forward and reverse are controlled by rotating the speed control lever as shown. The lever is spring loaded to return to neutral when released. Further rotation in either direction will progress the truck from slow to maximum travel speed.

To change directions or to stop the truck, rotate the speed control lever in the opposite direction. The truck will

come to a stop and then, unless the controls are returned to the center neutral position, accelerate in the opposite direction.

Steering

Moving the control handle (which connects to the steering arm) right or left will turn the truck right or left. When maneuvering around corners, make square turns and be sure there is adequate clearance.

Stopping

Stop the truck as gradually as possible. Unnecessary rapid stopping could be hazardous. Load could become unstable.

There are four possible ways to stop the truck:

1. **Plugging:** This electrical braking function consists of rotating the speed control lever in the opposite direction of travel and then releasing it when the truck stops. Plugging is a convenient way to stop the truck during normal operation. If the control is not released, the truck will accelerate in the opposite direction.
2. **Steering arm in horizontal position:** Lowering the steering arm to the horizontal position applies brake pad pressure to the brake disc. Lowering the steering arm below the horizontal position

increases the braking force and de-energizes the controls.

3. **Steering arm in vertical position:** Raising the steering arm to near vertical position applies brake pad pressure to the brake disc. Further vertical positioning increases the braking force and de-energizes the controls. This position services as a parking brake. As a safety precaution, the steering arm is spring loaded to return to the vertical position in the event the driver releases the control handle during operation. This is known as deadman braking.

Parking

When parking the truck, do not obstruct traffic lanes or aisles.

1. Park the truck in its designated parking area.

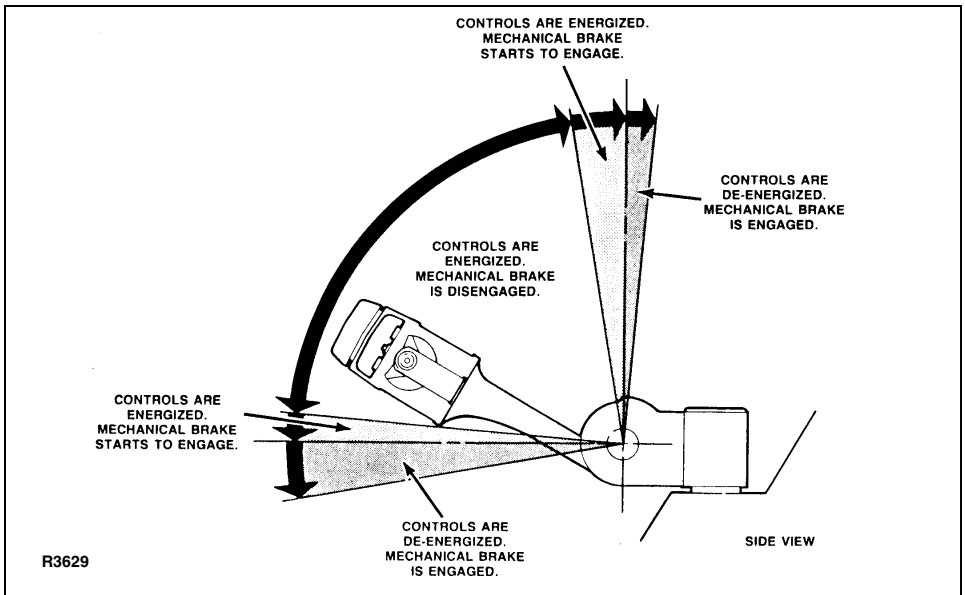

Steering Arm Braking Positions

2. Raise the steering arm until vertical to apply the parking brake.
3. Fully lower forks.
4. Turn keyswitch (if so equipped) to off position. Remove key for added security.
5. Pull out battery disconnect.

Battery Charging

Refer to DOC 245 for battery safety and maintenance.

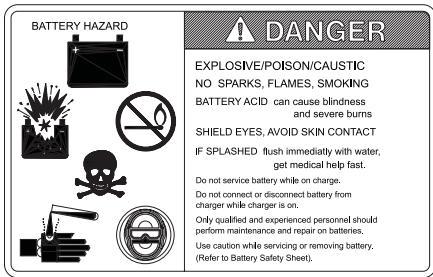

NOTE: Battery charging instructions are contained in the service manual.

Load Handling



WARNING:

Handle only loads arranged for stability and always use caution. Raise and lower the load smoothly to prevent the load from falling.



WARNING:

Always be sure the load and load center are within the capacity of the truck. If in doubt check the nameplate.

1. Approach the load slowly.

2. Move the truck slowly into position so that the forks are centered about the load.
3. Make sure the load is against the backrest and then raise the forks until the pallet clears the rack.
4. Lead the truck by the control handle with the load trailing except when in confined areas. Ramps should be traveled with operator uphill of truck when empty, or operator downhill of truck with load on forks.
5. Always look in the direction of travel. Move slowly and check clearances when approaching obstructions.
6. Do not make sudden starts and stops. Operate truck smoothly and gradually.
7. Travel slowly and squarely around corners. Remember that the trailing load wheels do not follow the turn path of the drive wheel. Instead they tend to cut the corner.
8. Line up the truck with the unloading area.
9. Stop the truck and check the load alignment with surrounding objects.
10. Be careful not to damage or move adjacent loads and objects.
11. Lower the forks until the load is resting on its own.
12. Move the truck back until the forks are clear of the pallet.

Moving a Disabled Truck

Do not attempt to move a disabled truck; notify your supervisor or proper authority.

The following operating instructions appear on the truck warning decal, which is located near the steering arm.

Do not operate this truck unless you have been trained and authorized to do so, and have read and understand all warnings and instructions contained in this operator's manual and on this truck.

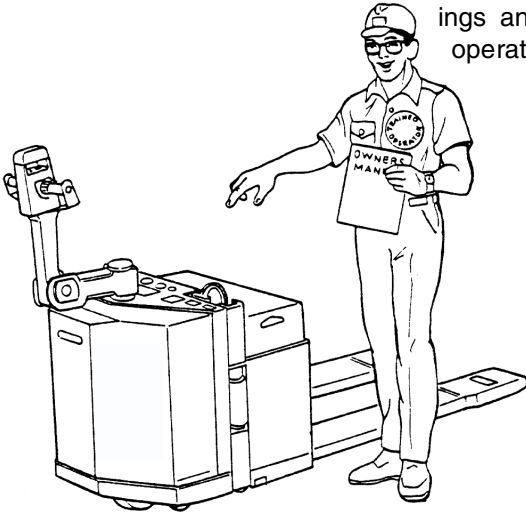

R4071

Do not operate this truck until you have checked its condition. Give special attention to tires, horn, battery, controller, lift systems, brakes, steering mechanism, guards and safety devices. If you have any questions, notify your supervisor or proper authority.

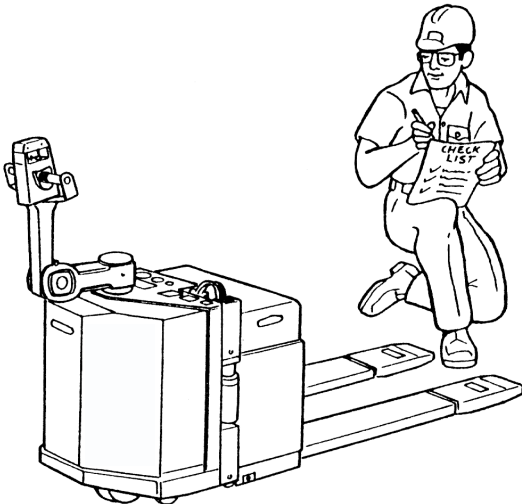

R4072

Walkie Pallet Trucks: Operate truck only from walking position.

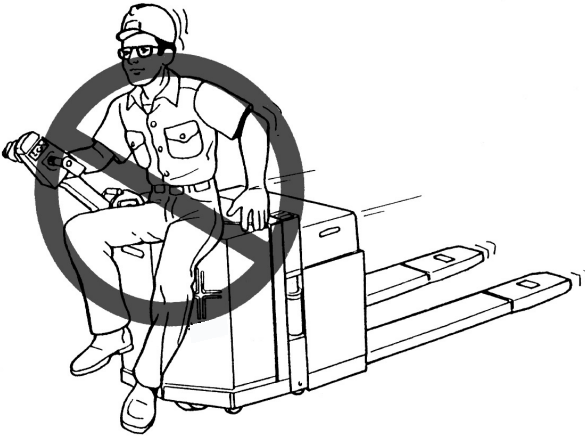

R4073

Walkie/Rider Pallet Trucks: Keep feet within limits of truck.

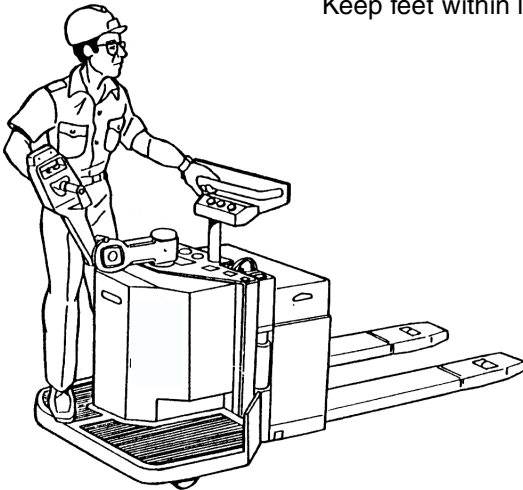

R4905

Wear foot protection and keep feet clear of truck.

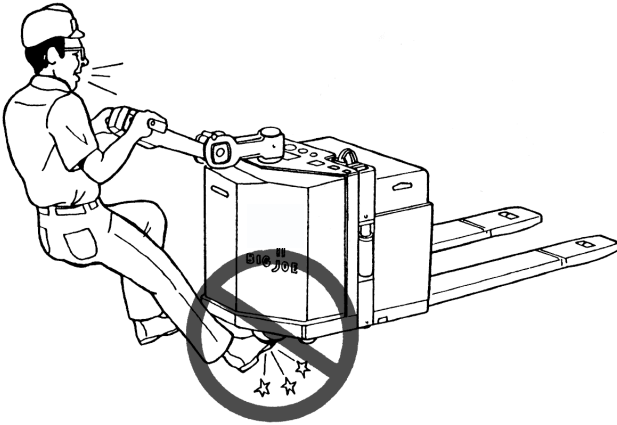

R4074

Do not carry passengers.



R4075

Observe applicable traffic regulations. Yield right-of-way to pedestrians. Slow down and sound horn at cross aisles and wherever vision is obstructed.

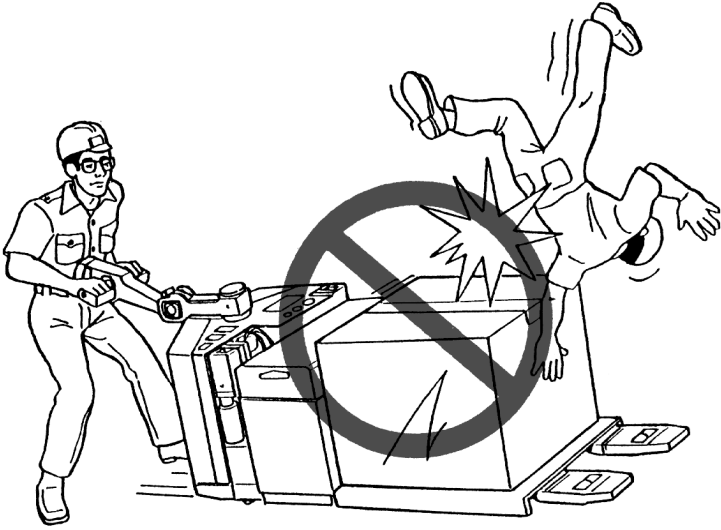

R4076

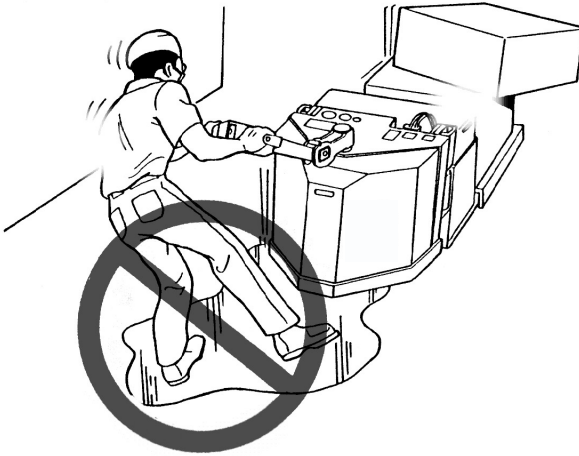

Start, stop, travel, steer and brake smoothly. Slow down for turns and on uneven or slippery surfaces that could cause truck to slide or overturn. Use special care when traveling without load as the risk of overturn may be greater.

R4077

Always look in direction of travel. Keep a clear view, and when load interferes with visibility, travel with load or lifting mechanism trailing (except when climbing ramps).

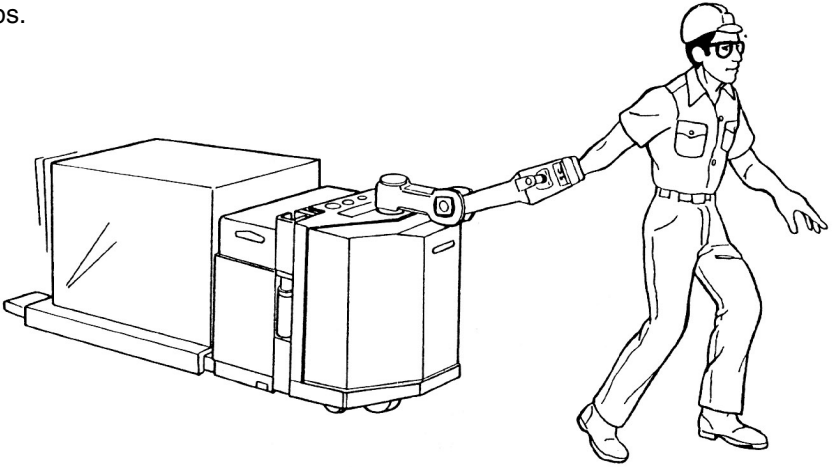

R4078

Use special care when operating on ramps; travel slowly, and do not angle or turn. Travel unloaded with lifting mechanism downhill, and travel loaded with load uphill.

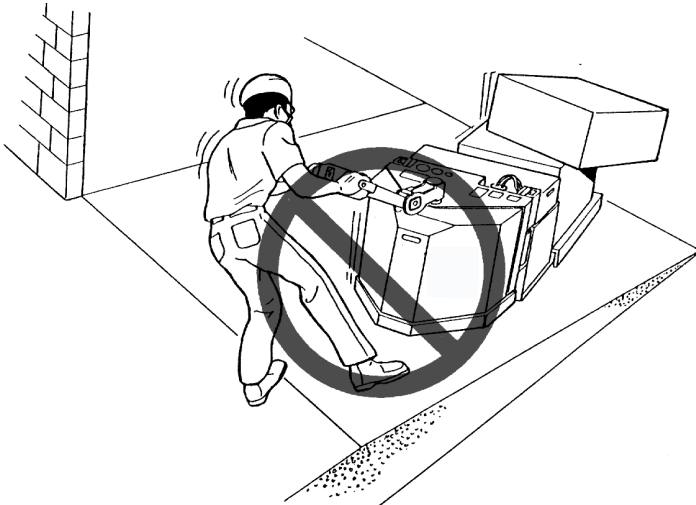

R4079

Do not handle loads which are higher than load backrest or load backrest extension unless load is secured so that no part of it could fall backward.

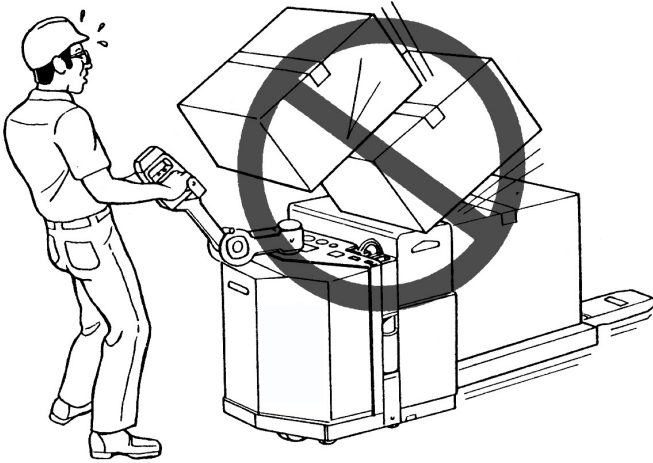

R4081

Before lifting, be sure load is centered, forks are completely under load, and load is as far back as possible against load backrest.

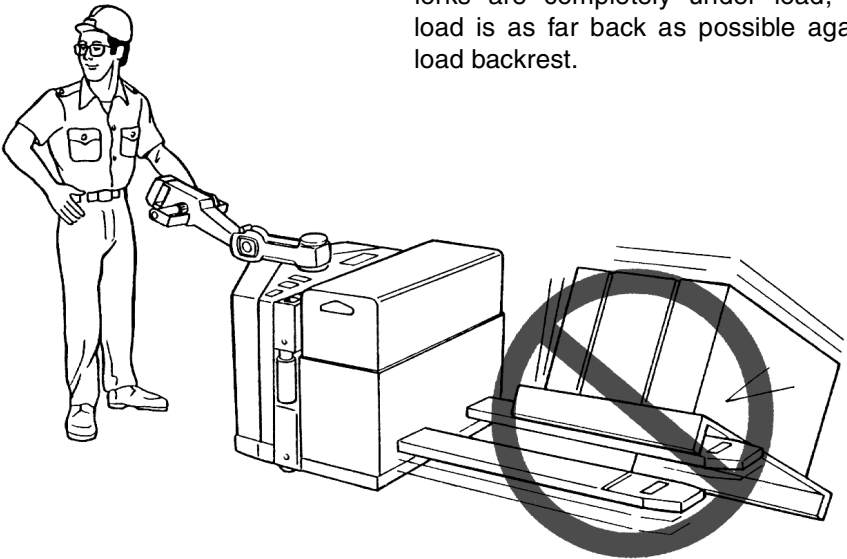

R4082

Keep hands out of lifting mechanism.



R4904

When leaving truck neutralize travel control. Fully lower lifting mechanism and set brake. When leaving truck unattended also shut off power.

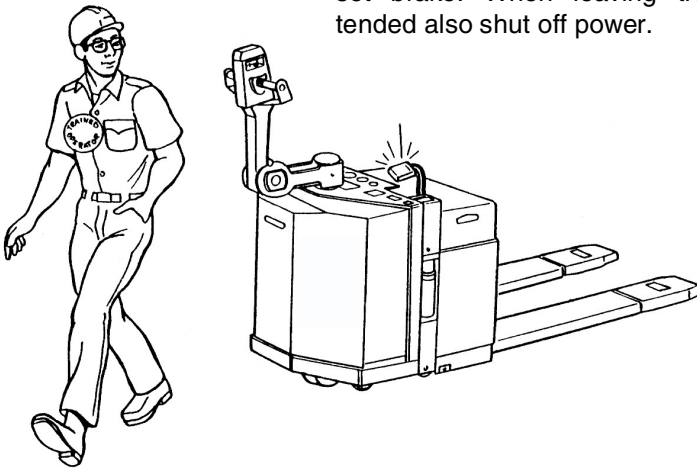

R4083

NOTICE - OBTAINING A PARTS AND SERVICE MANUAL

A complete parts and service manual covering this truck is available from Blue Giant Manufacturing Company. To order, obtain the serial number of your truck and contact your Blue Giant Authorized Dealer.

NOTES

NOTES

BLUE GIANT[®]
BLUE GIANT EQUIPMENT CORPORATION

Corporate 410 Admiral Blvd
Mississauga, ON, Canada L5T 2N6
t 905.457.3900 f 905.457.2313

USA 6350 Burnt Poplar Road
Greensboro, NC 27409
www.bluegiant.com