

OWNER'S MANUAL

BGL-22 WALKIE COUNTERBALANCED STACKER



WARNING

Do not operate or service this product unless you have read and fully understand the entire contents of this manual. Failure to do so may result in property damage, bodily injury or death.

BLUE GIANT[®]

ISSUE DATE: MAY 5, 2020 REV.0 (PART # 038-926E)

WARNING

Do not operate this truck unless you have been authorized and trained to do so, and have read all warnings and instructions in Operator's Manual and on this truck.

Do not operate this truck until you have checked its condition. Give special attention to tires, horn, battery, controller, lift system (including forks or attachments, chains, cables and limit switches), brakes, steering mechanism, guards and safety devices.

Operate truck only from designated operating position. Never place any part of your body into the mast structure or between the mast and the truck. Do not carry passengers. Keep feet clear of truck and wear foot protection.

Observe applicable traffic regulations. Yield right of way to pedestrians. Slow down and sound horn at cross aisles and wherever vision is obstructed.

Start, stop, travel, steer and brake smoothly. Slow down for turns and on uneven or slippery surfaces that could cause truck to slide or overturn. Use special care when traveling without load as the risk of overturn may be greater.

Travel with lifting mechanism as low as possible. Always look in direction of travel. Keep a clear view, and when load interferes with visibility, travel with load trailing.

Use special care when operating on ramps travel slowly, and do not angle or turn. Travel with load downhill.

Do not overload truck. Check nameplate for capacity and load center information.

When using forks, space forks as far apart as load will permit. Before lifting, be sure load is centered, forks are completely under load, and load is as far back as possible against load backrest.

Do not handle unstable or loosely stacked loads. Use special care when handling long, high or wide loads, to avoid losing the load, striking bystanders, or tipping the truck.

Do not handle loads which are higher than the load backrest or load backrest extension unless load is secured so that no part of it could fall backward.

Elevate forks or other lifting mechanism only to pick up or stack a load. Watch out for obstructions, especially overhead.

Do not lift personnel except on a securely attached specially designed work platform. **USE EXTREME CARE WHEN LIFTING PERSONNEL.** Make sure mast is vertical, place truck controls in neutral and apply brakes. Lift and lower smoothly. Remain in operating position or immediate vicinity as long as personnel are on the work platform. Never transport personnel on forks or work platform.

Do not allow anyone to stand or pass under load or lifting mechanism.

When leaving truck, neutralize travel control, fully lower lifting mechanism and set brake. When leaving truck unattended, also shut off power.

TABLE OF CONTENTS

Section	Page	Section	Page
1 DESCRIPTION	1-1	5-3. COMPARTMENT COVERS.....	5-6
1-1. INTRODUCTION.....	1-1	5-3.1. REMOVAL.....	5-6
1-2. GENERAL DESCRIPTION.....	1-1	5-3.2. INSTALLATION.....	5-6
1-3. SAFETY FEATURES.....	1-1		
2 OPERATION	2-1	6 BRAKE SERVICING	6-1
2-1. GENERAL.....	2-1	6-1. BRAKES.....	6-1
2-2. OPERATING PRECAUTIONS.....	2-1	6-1.1. BRAKE ASSEMBLY REPLACEMENT	6-1
2-3. BEFORE OPERATION.....	2-2		
2-4. GENERAL CONTROL OPERATION.....	2-4	7 TRANSMISSION, DRIVE WHEEL, LOAD WHEEL	7-1
2-5. DRIVING AND STOPPING PROCEDURES.....	2-4	7-1. DRIVE WHEEL.....	7-1
2-5.1. STOPPING.....	2-4	7-2. TRANSMISSION.....	7-1
2-6. BELLY-BUTTON SWITCH.....	2-5	7-3. LOAD WHEEL.....	7-1
2-7. STEERING ARM GAS SPRING.....	2-5	7-3.1. REMOVAL.....	7-1
2-8. LIFT AND LOWER CONTROLS.....	2-5	7-3.2. LOAD WHEEL INSTALLATION.....	7-1
2-9. TILT CONTROLS.....	2-5		
2-10. LOADING AND UNLOADING.....	2-5	8 ELEVATION SYSTEM SERVICING	8-1
2-11. PARKING.....	2-5	8-1. GENERAL.....	8-1
3 PLANNED MAINTENANCE	3-1	8-2. LIFT CHAIN LENGTH ADJUSTMENT.....	8-1
3-1. GENERAL.....	3-1	8-2.1. TELESCOPIC.....	8-1
3-2. MONTHLY AND QUARTERLY CHECKS.....	3-1	8-2.2. TRIMAST FREE LIFT CHAIN.....	8-3
3-3. BATTERY CARE.....	3-1	8-2.3. TRIMAST SECONDARY LIFT CHAIN.....	8-3
3-3.1. GENERAL.....	3-1	8-3. LIFT CHAIN WEAR INSPECTION.....	8-3
3-3.2. SAFETY RULES.....	3-2	8-4. LIFT CHAIN REPLACEMENT.....	8-5
3-3.3. BATTERY CARE AND CHARGING.....	3-2	8-4.1. TELESCOPIC.....	8-5
3-3.4. BATTERY CLEANING.....	3-2	8-4.2. TRIMAST FREE LIFT CHAIN.....	8-5
3-3.5. MAINTENANCE FREE BATTERIES.....	3-3	8-4.3. TRIMAST SECONDARY LIFT CHAIN.....	8-5
3-4. CHARGING BATTERIES.....	3-3	8-5. LIFT CYLINDERS.....	8-5
3-5. LUBRICATION.....	3-4		
3-6. LIFT CHAIN MAINTENANCE.....	3-4	9 HYDRAULIC SYSTEM SERVICING.....	9-1
4 TROUBLESHOOTING	4-1	9-1. LINES AND FITTINGS.....	9-1
4-1. GENERAL.....	4-1	9-2. HYDRAULIC PUMP, AND MOTOR ASSY	9-1
4-2. CONTROLLER TROUBLESHOOTING.....	4-4	9-2.1. REMOVAL.....	9-1
4-2.1. ZAPI HANDSET.....	4-4	9-2.2. DISASSEMBLY AND REASSEMBLY	9-1
4-2.2. FAULT DETECTION.....	4-4	9-2.3. INSTALLATION.....	9-3
4-2.3. TESTING TRUCK OPERATION.....	4-4	9-3. LIFT CYLINDER (TELESCOPIC).....	9-5
4-2.4. SETTINGS AND ADJUSTMENTS.....	4-5	9-3.1. REMOVAL.....	9-5
		9-3.2. REPAIR.....	9-5
		9-3.3. INSTALLATION.....	9-5
		9-4. LIFT CYLINDER (TRIMAST FREE LIFT)	9-8
		9-4.1. REMOVAL.....	9-8
		9-4.2. REPAIR.....	9-8
		9-4.3. INSTALLATION.....	9-8
		9-5. LIFT CYLINDER (TRIMAST SECONDARY) ..	9-11
		9-5.1. REMOVAL.....	9-11
		9-5.2. REPAIR.....	9-11
		9-5.3. INSTALLATION.....	9-11
		9-5.4. TILT CYLINDERS.....	9-13
5 STEERING ARM, CONTROL HEAD AND COMPARTMENT	5-1	10 ELECTRICAL COMPONENTS	10-1
5-1. CONTROL HEAD.....	5-1	10-1. ELECTRICAL CONTROL PANEL	10-1
5-1.1. CAP ASSEMBLY REMOVAL.....	5-1	10-1.1. MAINTENANCE.....	10-1
5-1.2. CAP ASSEMBLY INSTALLATION.....	5-2	10-1.2. CLEANING.....	10-1
5-1.3. CONTROL HEAD REMOVAL.....	5-3	10-1.3. PANEL REMOVAL.....	10-1
5-1.4. CONTROL HEAD INSTALLATION.....	5-3	10-1.4. PANEL DISASSEMBLY.....	10-1
5-1.5. SPEED POTENTIOMETER REPLACEMENT.....	5-3	10-1.5. PANEL INSTALLATION.....	10-1
5-1.6. BELLY-BUTTON SWITCH REPLACEMENT.....	5-3	10-2. HORN REPLACEMENT.....	10-1
5-1.7. HORN SWITCH REPLACEMENT.....	5-3		
5-1.8. LIFT AND LOWER SWITCH REPLACEMENT.....	5-4	10-3. PUMP MOTOR.....	10-4
5-1.9. TILT SWITCH REPLACEMENT.....	5-6		
5-2. STEERING ARM.....	5-6		
5-2.1. RETURN SPRING REPLACEMENT.....	5-6		
5-2.2. STEERING ARM REMOVAL.....	5-6		
5-2.3. STEERING ARM INSTALLATION.....	5-6		

TABLE OF CONTENTS - Continued

10-4. DRIVE MOTOR..... 10-4	11 OPTIONAL EQUIPMENT 11-1
10-4.1.MOTOR REMOVAL..... 10-4	
10-4.2.MOTOR INSTALLATION..... 10-4	12 ILLUSTRATED PARTS BREAKDOWN 12-1
10-5. DEADMAN SWITCH..... 10-4	
10-5.1.REPLACEMENT..... 10-4	

LIST OF ILLUSTRATIONS

Figure	Page	Figure	Page		
1-1	NAME PLATE.....	1-1	9-8	SECONDARY LIFT CYLINDER (TRIMAST)	9-12
1-2	BGL-22 LIFT TRUCK.....	1-2	9-9	TILT CYLINDER MOUNTING.....	9-13
2-1	LOAD CENTER.....	2-1	9-10	TILT CYLINDER.....	9-15
2-2	SAMPLE OF OPERATOR CHECK LIST.....	2-3	10-1	ELECTRICAL SYSTEM.....	10-2
2-3	FORWARD/REVERSE CONTROL.....	2-4	10-2	ELECTRICAL PANEL.....	10-3
2-4	PUSHBUTTON SWITCHES.....	2-4	10-3	TRANSMISSION, MOTOR, BRAKE ASSEMBLY	10-5
2-5	BRAKE ACTUATION.....	2-5	12-1	STEERING SYSTEM.....	12-2
2-6	BELLY-BUTTON SWITCH.....	2-5	12-2	CONTROL HEAD.....	12-4
3-1	LUBRICATION DIAGRAM.....	3-5	12-3	CAP ASSEMBLY.....	12-6
4-1	ZAPI CONTROLLER.....	4-4	12-4	EMERGENCY REVERSE SWITCH ASSY.....	12-8
4-2	ZAPI HANDSET.....	4-5	12-5	TRANSMISSION, MOTOR, BRAKE ASSY.....	12-10
4-3	ZAPI HANDSET.....	4-9	12-6	COMPARTMENT.....	12-12
4-4	THROTTLE REGULATION.....	4-10	12-7	FRAME.....	12-14
4-5	ZAPI HANDSET.....	4-11	12-8	LOAD WHEELS.....	12-16
4-6	ZAPI CONTROLLER CONNECTIONS.....	4-13	12-9	ELEVATION SYSTEM (TELESCOPIC).....	12-18
5-1	CONTROL HEAD.....	5-1	12-10	ELEVATION SYSTEM (TRIMAST).....	12-20
5-2	STEERING ARM.....	5-2	12-11	LIFT CARRIAGE.....	12-22
5-3	EMERGENCY REVERSE SWITCH ASSEMBLY..	5-4	12-12	CHAIN ASSEMBLY.....	12-24
5-4	CAP ASSEMBLY.....	5-5	12-13	HYDRAULIC SYSTEM.....	12-26
6-1	TRANSMISSION, MOTOR, BRAKE ASSEMBLY.	6-2	12-14	PUMP & MOTOR.....	12-28
7-1	TRANSMISSION, MOTOR, BRAKE ASSEMBLY.	7-2	12-15	HYDRAULIC SYSTEM (TELESCOPIC).....	12-30
7-2	LOAD WHEELS.....	7-3	12-16	HYDRAULIC SYSTEM (TRIMAST).....	12-32
8-1	CHAIN ASSEMBLY.....	8-1	12-17	TILT CYLINDER MOUNTING.....	12-34
8-2	ELEVATION SYSTEM (TELESCOPIC).....	8-2	12-18	LIFT CYLINDER (TELESCOPIC).....	12-36
8-3	MAST (TRIMAST).....	8-4	12-19	FREE LIFT CYLINDER (TRIMAST).....	12-38
9-1	HYDRAULIC SYSTEM.....	9-2	12-20	SECONDARY LIFT CYLINDER (TRIMAST).....	12-40
9-2	HYDRAULIC SYSTEM (TELESCOPIC).....	9-3	12-21	TILT CYLINDER.....	12-42
9-3	HYDRAULIC SYSTEM (TRIMAST).....	9-4	12-22	ELECTRICAL SYSTEM.....	12-44
9-4	ELEVATION SYSTEM (TELESCOPIC).....	9-6	12-23	ELECTRICAL PANEL.....	12-46
9-5	LIFT CYLINDER (TELESCOPIC).....	9-7	12-24	DRIVE MOTOR.....	12-48
9-6	ELEVATION SYSTEM (TRIMAST).....	9-9	12-25	WIRING HARNESS.....	12-50
9-7	FREE LIFT CYLINDER (TRIMAST).....	9-10	12-26	WIRING CABLES.....	12-51

LIST OF TABLES

Table	Page	Table	Page		
2-1	OPERATOR CHECKS.....	2-2	4-2	SET OPTIONS.....	4-5
3-1	MONTHLY AND QUARTERLY INSPECTION AND SERVICE CHART.....	3-1	4-3	ADJUSTMENTS.....	4-9
3-2	RECOMMENDED LUBRICANTS.....	3-4	4-4	PARAMETER ADJUSTMENTS.....	4-11
3-3	LUBRICATION CHART.....	3-5	4-5	ZAPI CONTROLLER CONNECTOR PINS.....	4-13
4-1	TROUBLESHOOTING CHART.....	4-1			

SECTION 1 DESCRIPTION

1-1. INTRODUCTION.

This publication describes the 24 volt transistor BGL-22 lift truck distributed by Blue Giant. Included are operating instructions, planned maintenance instructions, lubrication procedures, corrective maintenance procedures and a complete parts list with part location illustrations.

Users shall comply with all requirements indicated in applicable OSHA standards and current edition of A.N.S.I. B56.1 Part II. By following these requirements and the recommendations contained in this manual, you will receive many years of dependable service from your BGL-22 lift truck.

1-2. GENERAL DESCRIPTION.

The self-propelled BGL-22 truck, [Figure 1-2](#), lifts and transports payloads up to 2200 pounds on adjustable forks.

The forward and reverse motion is controlled by either of two controller levers mounted on the control head. Stopping and turning is controlled by the steering arm. Lift, Lower and Tilt are controlled by pushbuttons on the control head. The battery powered lift truck is quiet and without exhaust fumes.

The reversible AC motor propels the lift truck in forward or reverse direction throughout the available speed range. The BGL-22 lift truck can be driven with forks raised or lowered; however, the speed is restricted when the platform is raised above a preset limit.

The model number will be found on the name plate ([Figure 1-1](#)) along with the serial number, lifting capacity, and load center. [Figure 1-2](#) shows the locations of the truck's main components and controls.

1-3. SAFETY FEATURES.

The BGL-22 is designed and engineered to provide maximum safety for operator and payload. Some of the safety features incorporated into the design are:

- Dead-man brake to apply the brake and cut off drive power when the steering arm is released.

- Belly-button switch to reverse truck should the operator accidentally pin himself against a wall or obstruction when backing up in slow speed.

MODEL NO. SERIAL NO.

MAX CAP LB/ KG LOAD CTR IN/ MM LIFT HGT IN/ MM

ALT CAP LB/ KG LOAD CTR IN/ MM LIFT HGT IN/ MM

TRUCK WT LESS BATTERY LB/ KG BATTERY MIN WT LB/ KG

TRUCK WT WITH BATTERY LB/ KG BATTERY MAX WT LB/ KG

TRUCK TYPE BATTERY TYPE CERTIFIED VOLTAGE

COMPLIES WITH THE APPLICABLE REQUIREMENTS OF ANSI B56.1 AND OSHA STANDARDS

R6209

Figure 1-1 Name Plate

- High speed limit switch to restrict speed when lift carriage is raised above the preset limit.
- All control functions automatically return to "OFF" when released.
- Externally accessible quick-disconnect battery plug within operator's reach.
- Separately fused control circuits and power circuits.
- Readily accessible horn button.
- Lift carriage backrest to help stabilize the load.
- Handle to provide a firm hand hold for operator.
- Flow control valve regulates maximum lowering speed within prescribed limits.
- Relief valve maintains hydraulic pressure within prescribed limits.
- High visibility color scheme of truck provides visual alert of truck's presence.
- Battery Indicator.

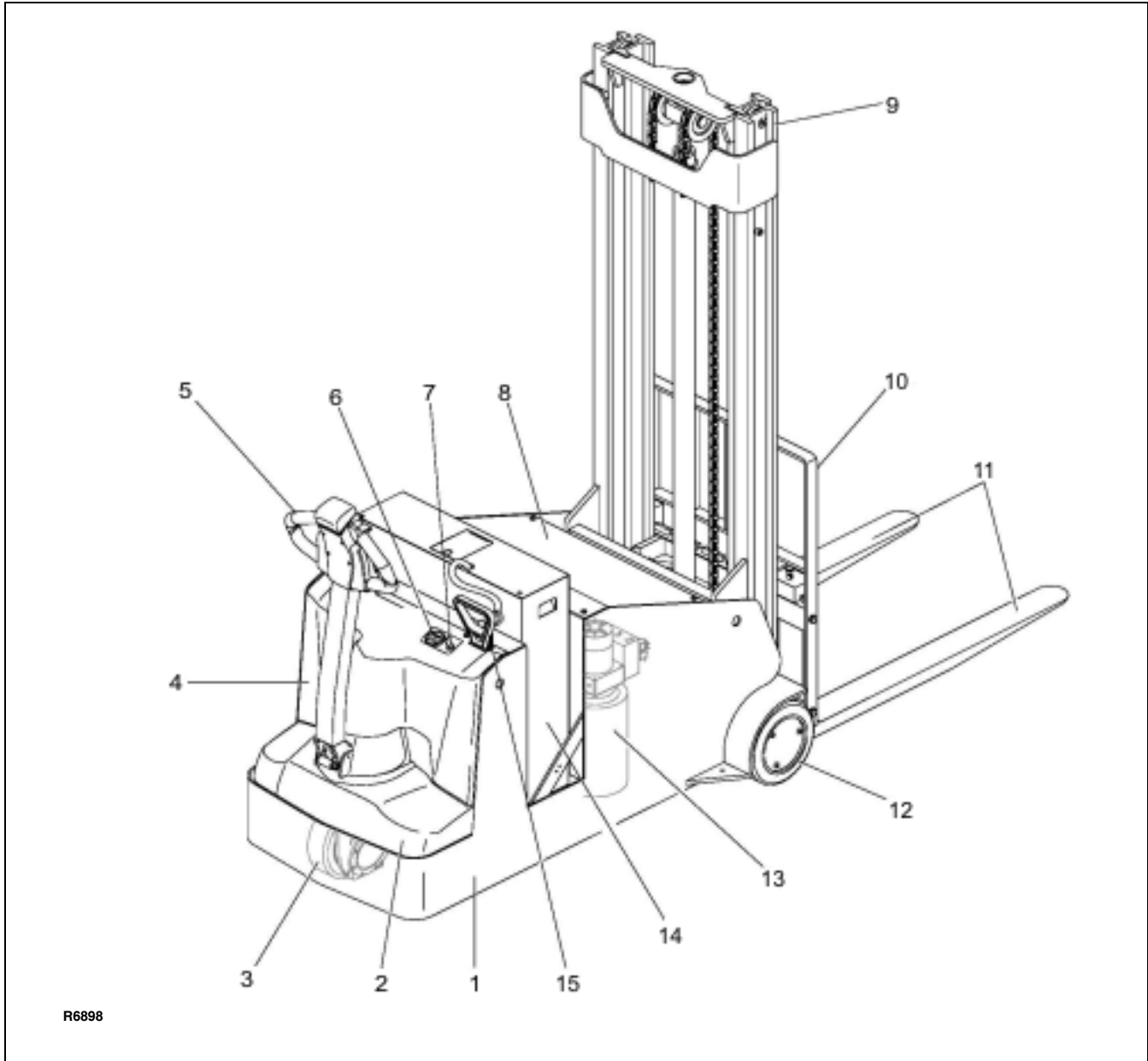

R6898

Figure 1-2. BGL-22 Lift Truck

ITEM	COMPONENT
1	Chassis
2	Cover
3	Drive wheel
4	Cover
5	Control Handle
6	Battery Indicator
7	Key Switch
8	Front cover

ITEM	COMPONENT
9	Mast
10	Back Rest
11	Forks
12	Load Wheel
13	Hydraulic pump
14	Battery
15	Battery Disconnect

SECTION 2 OPERATION

2-1. GENERAL.

This section gives detailed operating instructions for the BGL-22 lift truck. The instructions are divided into the various phases of operations, such as operating lift, driving, and stopping. Routine precautions are included for safe operation.

2-2. OPERATING PRECAUTIONS.

WARNING: Improper operation of the lift truck may result in operator injury, or load and/or lift truck damage. Observe the following precautions when operating the BGL-22 lift truck.

The following safety precautions must be adhered to at all times.

- Do not operate this truck unless you have been trained and authorized to do so.
- All warnings and instructions must be read and understood before using the equipment.
- Equipment must not be altered in any way.
- Equipment must be inspected by a qualified person on a regular basis.
- Do not exceed the rated capacity. Overloading may result in damage to the hydraulic system and structural components.
- Be certain that the lifting machine is operating smoothly throughout its entire height, both empty and loaded.
- Be sure that mast is vertical - do not operate on a side slope.
- Be sure the truck has a firm and level footing.
- Avoid overhead wires and obstructions.
- Check for obstructions when raising or lowering the lift carriage.
- Do not handle unstable or loosely stacked loads. Use special care when handling long, high, or wide loads to avoid tipping, loss of load, or striking bystanders.
- Center and carry the load as far back as possible toward the lift carriage back rest. The center-of-gravity of the load must not exceed the load center listed on the nameplate. See [Figure 2-1](#) for load center limitations.
- Pick up loads on both forks. Do not pick up on only one fork.
- When traveling, always lower the load as far as possible.

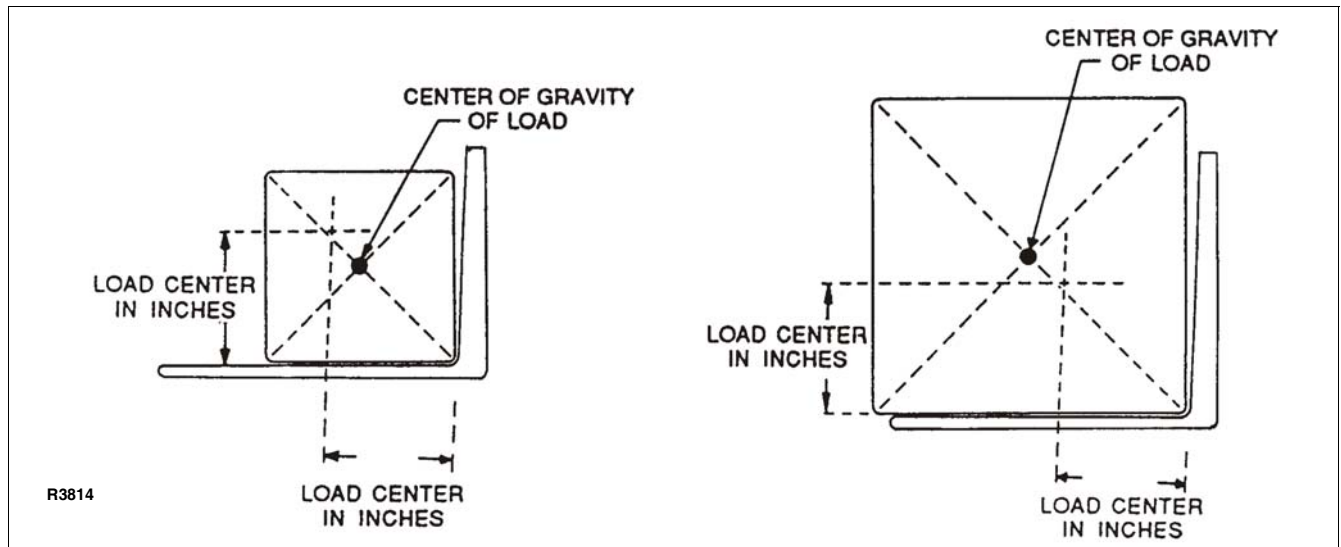

Figure 2-1 Load Center

- When stacking pallets in racks and it is necessary to move the load in a raised position, use caution. Operate truck smoothly.
- Observe applicable traffic regulations. Yield right of way to pedestrians. Slow down and sound horn at cross aisles and wherever vision is obstructed.
- Operate truck only from designated operation position. Never place any part of your body between the mast uprights. Do not carry passengers.
- Do not allow anyone to stand or pass under load or lifting mechanism.
- When leaving truck, neutralize travel control. Fully lower lifting mechanism and set brake. When leaving truck unattended, turn off key switch, remove key and disconnect battery.

2-3. BEFORE OPERATION

Table 2-1 covers important inspection points on the BGL-22 lift truck which should be checked prior to operation. Depending on use, some trucks may require additional checks.

Table 2-1 Operator Checks

ITEM	PROCEDURE
Transmission and hydraulic systems.	Check for signs of fluid leakage.
Forks	Check for cracks and damage; and, that they are properly secured.
Chains, cables and hoses	Check that they are in place, secured correctly, functioning properly and free of binding or damage.
Guards and load backrest	Check that safety guards are in place, properly secured and not damaged.
Safety signs	Check that warning labels, nameplate, etc., are in good condition and legible.
Horn	Check that horn sounds when operated.
Steering	Check for binding or looseness in steering arm when steering.
Travel controls	Check that speed controls on control head operate in all speed ranges in forward and reverse and that belly button switch functions.

Figure 2-2 shows a sample format for an Operator Checklist, which can be modified as necessary to fit your operation.

WARNING: Periodic maintenance of this truck by a QUALIFIED TECHNICIAN is required.

CAUTION: A QUALIFIED SERVICE TECHNICIAN should check the truck monthly for proper lubrication, proper fluid levels, brake maintenance, motor maintenance and other areas specified in the SECTION 3.

WARNING: If the truck is found to be unsafe and in need of repair, or contributes to an unsafe condition, report it immediately to the designated authority. Do not operate it until it has been restored to a safe operating condition. Do not make any unauthorized repairs or adjustments. All service must be performed by a qualified maintenance technician.

ITEM	PROCEDURE
Wheels	Check drive wheel for cracks or damage. Move truck to check load for freedom of rotation.
Hydraulic controls	Check operation of lift, lower and tilt to their maximum positions.
Brakes	Check that brakes actuate when steering arm is raised to upright position, and when lowered to horizontal position.
Deadman/ Parking brake	Check that steering arm raises to upright position when released and brake applies.
Battery disconnect	Check that battery can be disconnected and reconnected. Check for connector damage.
Battery charge	Check the battery indicator.
High speed limit switch	Allow for enough space to operate truck in high speed. Elevate forks approximately two feet, then test drive truck to check if high speed is cut out.

Electric Truck Daily Operator Check-Off List

Date _____ Operator _____

Truck No. _____ Model No. _____

Dept. _____ Shift _____

Hour Meter
Reading—Drive _____ Hoist _____

Check	O.K. (✓)	Need Maintenance
Tires		
Load Wheels		
Horn		
Lift—Lower Control		
Attachment Operation		
Forward & Reverse Controls		
Steering		
Brakes		
Hydraulic Leaks, Cylinders, Valves, Hoses, Etc.		

R6479

Figure 2-2 Sample of Operator Check List

2-4. GENERAL CONTROL OPERATION.

The speed control (See [Figure 2-3](#)) located on each side of the control head provides fingertip control for driving the truck. Rotate the control in the direction you want to travel. The farther you rotate the control from the neutral position, the faster the truck will travel.

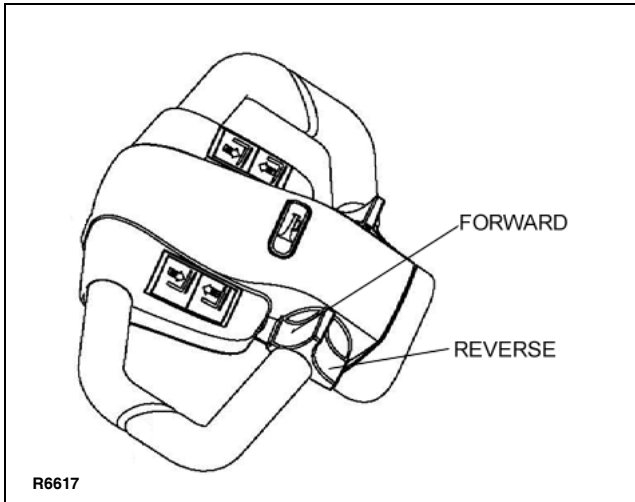

Figure 2-3. Forward/Reverse Control

The pushbutton switches (See [Figure 2-4](#)), located on the front of the control head activate the lift, lower, tilt and horn.

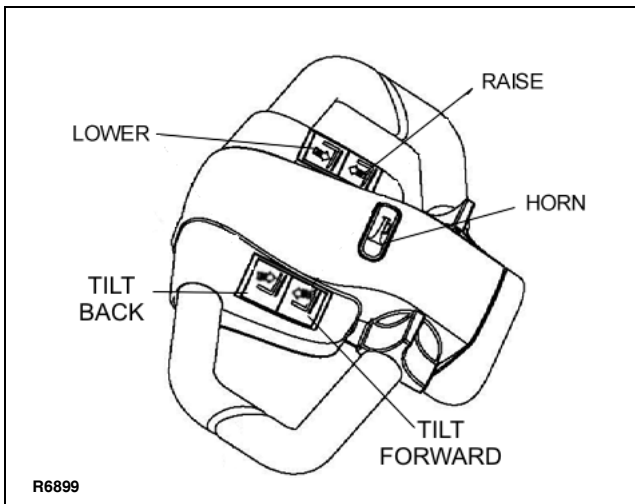

Figure 2-4. Pushbutton Switches

2-5. DRIVING AND STOPPING PROCEDURES.

1. Connect the batteries and turn on the key switch. Grasp the grips of the steering head so that the speed control can be comfortably operated by either thumb.

2. Lower the steering arm to a comfortable position above horizontal to disengage the brake and to energize the electrical circuits. If the truck is not moved, the electrical circuits will time out and will deenergize. See [Figure 2-5](#).
3. To move forward (with load in front), slowly press the speed control forward. See [Figure 2-3](#). Press the forward speed control farther to increase speed.
4. To slow down or stop, release the speed control and lower or raise the steering arm to the horizontal or vertical position. See [Figure 2-5](#). In those positions, the brake engages, slowing or stopping the truck.
5. Procedures for movement in reverse are the same as in the forward direction except slowly press the speed control backward. See [Figure 2-3](#).

2-5.1. Stopping

The brake pattern of the truck depends on the ground conditions. The driver must take this into account when operating the truck.

The driver must be looking ahead when traveling. If there is no hazard, brake moderately to avoid moving the load.

There are four different ways to stop the truck:

1. **Plugging:** This electrical braking function consists of rotating the speed control lever in the opposite direction of travel and then releasing it when the truck stops. Plugging is a convenient way to stop the truck during normal operation. If the control is not released, the truck will accelerate in the opposite direction.
2. **Steering arm (See [Figure 2-5](#)):** The brake is fully applied by lowering or raising the steering arm. (See [Figure 2-5](#)) All traction control power is shut off when the brake is engaged. When the steering arm is in the upright position, the brake acts as a parking brake. Deadman braking occurs when the handle is released and spring action raises steering arm to the upright position.
3. **Emergency braking:** Press the emergency brake switch, all electrical functions are cut out and the truck automatically brakes.
4. **Regenerative braking:** If the speed control lever is released, the truck automatically brakes regeneratively. When the speed is below .5 MPH, the brake applies

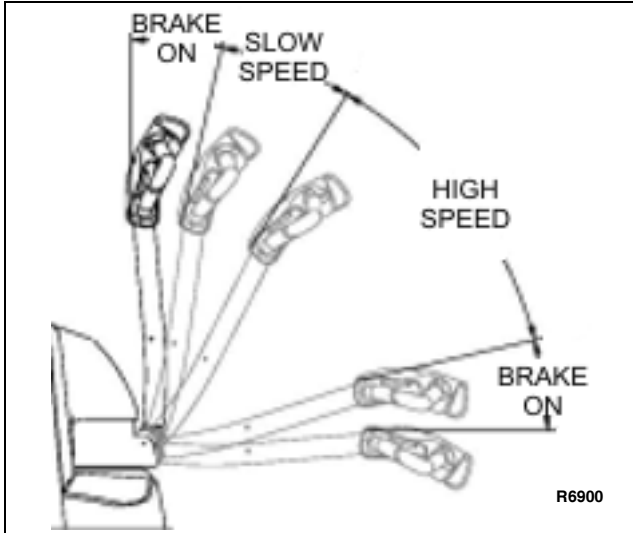

Figure 2-5. Brake Actuation

2-6. .BELLY-BUTTON SWITCH.

The belly-button switch (Figure 2-6) minimizes the possibility of the driver being pinned by the steering arm while driving the lift truck in slow speed. If the switch presses against the operator while the lift truck is being driven toward the operator, the switch changes the direction of the lift truck.

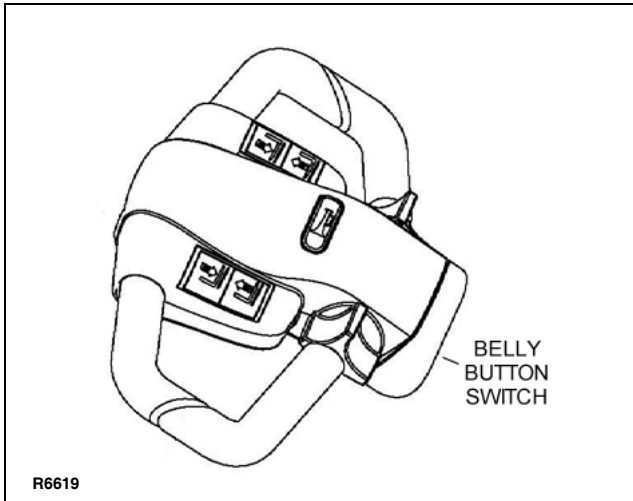

Figure 2-6. Belly-Button Switch

2-7. STEERING ARM GAS SPRING.

The steering arm gas spring automatically raises the steering arm to the upright position when the steering arm is released. If the steering arm does not return fully, the steering arm gas spring requires replacement. Return truck to maintenance for repair.

2-8. LIFT AND LOWER CONTROLS.

Lift/Lower Control buttons are located on the steering control head. (Figure 2-4)

To lift forks, push in the LIFT button and hold until forks reach desired height. To lower forks, push in the LOWER button and hold until forks descend to desired height.

2-9. TILT CONTROLS.

Tilt Control buttons are located on the steering control head. (Figure 2-4)

To tilt forks back, push in the TILT BACK button and hold until forks reach desired angle. To tilt the forks forward, push in the TILT FORWARD button and hold until forks descend to desired angle.

2-10.LOADING AND UNLOADING.

1. Move truck to location where load is to be picked up.
2. Move the truck into position so forks are within pallet or skid, and the load is centered over the forks and as far back as possible.
3. Raise forks to lift load.
4. Tilt the forks to level the load.
5. Drive to area where load is to be placed.
6. Move truck to align load with its new position.
7. Lower the load and tilt until it rests squarely in place and the forks are free.
8. Slowly move the truck out from under the load.

2-11.PARKING.

When finished with moving loads, return the truck to its maintenance or storage area. Turn off the key switch and disconnect the batteries. Charge batteries as necessary. Refer to battery care instructions, SECTION 3.

NOTES

SECTION 3 PLANNED MAINTENANCE

3-1. GENERAL.

Planned maintenance consists of periodic visual and operational checks, parts inspection, lubrication, and scheduled maintenance designed to prevent or discover malfunctions and defective parts. The operator performs the checks in [SECTION 2](#), and refers any required servicing to a qualified maintenance technician who performs the scheduled maintenance and any required servicing.

3-2. MONTHLY AND QUARTERLY CHECKS.

[Table 3-1](#) is a monthly and quarterly inspection and service chart based on normal usage of equipment eight hours per day, five days per week. If the lift truck is used in excess of forty hours per week, the frequency of inspection and service should be increased accordingly. These procedures must be performed by a qualified service technician or your Blue Giant Service Representative.

3-3. BATTERY CARE.

3-3.1. General

The BGL-22 may be equipped with maintenance free or industrial wet cell batteries.

The care and maintenance of the battery is very important to obtain efficient truck operation and maximum battery life.

CAUTION: Gases produced by a battery can be explosive. Do not smoke, use an open flame, create an arc or sparks in the vicinity of the battery. Ventilate an enclosed area well when charging.

CAUTION: Batteries contain sulfuric acid which may cause severe burns. Avoid contact with eyes, skin or clothing. In case of contact, flush immediately and thoroughly with clean water. Obtain medical attention when eyes are affected. A baking soda solution (one pound to one gallon of water) applied to spilled acid until bubbling stops, neutralizes the acid for safe handling and disposal.

Leakage voltage from battery terminals to battery case can cause misleading trouble symptoms with the truck electrical system. Since components of the truck electrical system are insulated from truck frame, leakage voltage will not normally affect truck operation unless a short circuit or breakdown of circuit wire insulation to truck frame occurs.

A voltage check from battery connector terminal to battery case should indicate near zero volts. Typically, however, the sum of the voltages at both terminals will equal battery volts. This leakage voltage will discharge the battery. As battery cleanliness deteriorates, the usable charge of the battery decreases due to this self discharge.

Table 3-1 Monthly and Quarterly Inspection and Service Chart

VISUAL CHECKS	
INTERVAL	INSPECTION OR SERVICE
Monthly	Check electrical brake for proper operation.
Monthly	Check load wheels for wear. A poly load wheel must be replaced if worn to within 1/16 inch of hub. Check for separation from hub.
Monthly	Check drive wheel for wear. A poly drive wheel must be replaced if worn to within 3/4 inch of hub. Check for separation from hub.
Monthly	Inspect wiring for loose connections and damaged insulation.
Monthly	Inspect contactors for proper operation.
Monthly	Check deadman brake switch for proper operation.
Monthly	Check lift chain tension, lubrication & operation (see paragraph 3-6.)
Quarterly	Check lift and tilt cylinders for leakage.
Quarterly	Check for excessive jerking of steering arm when stopping or starting.
Semi-annually	Inspect for chain wear (See SECTION 8)

Although a leakage voltage reading of zero volts may not be possible, a cleaner battery will have more usable charge for truck operation and not affect operation of electronic devices on the unit.

3-3.2. Safety Rules

- Wear protective clothing, such as rubber apron, gloves, boots and goggles when performing any maintenance on batteries. Do not allow electrolyte to come in contact with eyes, skin, clothing or floor. If electrolyte comes in contact with eyes, flush immediately and thoroughly with clean water. Obtain medical attention immediately. Should electrolyte be spilled on skin, rinse promptly with clean water and wash with soap. A baking soda solution (one pound to one gallon of water) will neutralize acid spilled on clothing, floor or any other surface. Apply solution until bubbling stops and rinse with clean water.
- If truck is equipped with wet cell batteries, keep vent plugs firmly in place at all times except when adding water or taking hydrometer readings. Do not allow dirt, cleaning solution or other foreign material to enter cells. Impurities in electrolyte has a neutralizing effect reducing available charge.
- Do not bring any type of flame, spark, etc., near the battery. Gas formed while the battery is charging, is highly explosive. This gas remains in the cells long after charging has stopped.
- Do not lay metallic or conductive objects on battery. Arcing will result.
- Do not touch non-insulated parts of DC output connector or battery terminals to avoid possible electrical shock.
- De-energize all AC and DC power connections before servicing battery.
- Do not charge a frozen battery.
- Do not use charger if it has been dropped or otherwise damaged.

3-3.3. Battery Care and Charging

CAUTION: Never smoke or bring open flame near the battery. Gas formed during charging is highly explosive and can cause serious injury.

1. Charge the battery only in areas designated for that use.
2. Make certain the charger being used matches the voltage and amperage of the truck battery.
3. Before disconnecting or connecting batteries to a charger, make sure the charger is "OFF". If an attempt is made to do this while the charger is "ON", serious injury to you, the battery and the charger could result.
4. Before connecting the battery cable to the trucks receptacle, make sure the key switch is off. The battery cable must be fully connected before the truck is used. If the plug is not making good contact, heat will weld the two parts of the battery connector together, making it difficult to remove and necessary to replace.
5. Battery terminals should be checked and cleaned of corrosion regularly. Good battery terminal contact is essential not only for operation, but also for proper charging of the battery.
6. The charging requirements will vary depending on the use of the truck. The battery should be given as equalizing charge on a weekly basis. This charge should normally be an additional three hours at the finish rate.
7. Make certain battery used meets weight and size requirements of truck. NEVER operate truck with an undersized battery.

3-3.4. Battery Cleaning

Always keep vent plugs tightly in place when cleaning battery. When properly watered and charged, the battery will remain clean and dry. All that is necessary is to brush or blow off any dust or dirt that may accumulate on them. However, if electrolyte is spilled or overflows from a cell, it should be neutralized with a solution of baking soda and water, brushing the soda solution beneath the connectors and removing grime from the covers. Then rinse the battery with cool water from a low pressure supply to remove the soda and loosen dirt. If batteries stay wet consistently, they may be either overcharged or over filled. This condition should be investigated and corrected.

3-3.5. MAINTENANCE FREE BATTERIES

Some trucks may be equipped with maintenance free batteries. These batteries are completely sealed, will not require any watering and have a full 80% discharge available.

Sealed Maintenance Free batteries contain a pressure release valve and under normal operating conditions do not require any special ventilation.

CAUTION: Do not try to open this battery or remove the pressure release valve.

Only under severe overcharging, such as connected to an improperly sized charger, will any significant amount of gasses be released from the battery. Also, being a valve regulated battery, it never requires watering.

3-4. CHARGING BATTERIES

Charging requirements will vary depending on depth of discharge and temperature. Follow safety rules when placing a battery on charge.

Proceed as follows:

1. Park truck at charging station with carriage lowered and turn the key switch off.
2. Check the condition of the AC cord, the battery connector and battery cables. If there are any cuts in the cable, any exposed wires, loose plugs or connectors, **DO NOT** attempt to charge the batteries. Contact appropriate personnel for repairs to be made.
3. Disconnect the batteries from the truck and connect the batteries to the charger. Make sure connectors are mated properly.
4. Connect the charger to the appropriate power supply.
5. Follow the instructions for the charger being used.

<p>BATTERY HAZARD</p> 	<p>! DANGER</p> <p>EXPLOSIVE/POISON/CAUSTIC NO SPARKS, FLAMES, SMOKING BATTERY ACID can cause blindness and severe burns SHIELD EYES, AVOID SKIN CONTACT IF SPLASHED flush immediately with water, get medical help fast.</p> <p>Do not service battery while on charge. Do not connect or disconnect battery from charger while charger is on. Only qualified and experienced personnel should perform maintenance and repair on batteries. Use caution while servicing or removing battery. (Refer to Battery Safety Sheet).</p>
---	--

3-5. LUBRICATION.

Refer to [Table 3-2](#) for the recommended types of grease and oil. [Table 3-3](#) in conjunction with [Figure 3-1](#) identifies the items requiring lubrication.

3-6. LIFT CHAIN MAINTENANCE.

Fully raise and lower lift carriage while observing chains as they move over chain sheaves. Ensure chain is aligned and tracking properly and all links are pivoting freely. With lift carriage fully lowered, spray or brush on a film of SAE 30 or 40 engine oil.

**Table 3-2 Recommended Lubricants
(See [Table 3-3](#) for Application)**

No. 1	Transmission oil—EP SAE 80W-90 Transmission oil—EP SAE 10W-30 (Note)
No. 2	Grease—Lithium base, general purpose.
No. 3	Hydraulic oil-Heavy duty with a viscosity of 150 SUS foam suppressing agent and rust and oxidation inhibitors Hydraulic oil-Heavy duty with a viscosity of 100 SUS foam suppressing agent and rust and oxidation inhibitors (Note)
No. 4	SAE 30 or 40 Engine lubricating oil

NOTE: USED ON COLD CONDITIONED TRUCKS

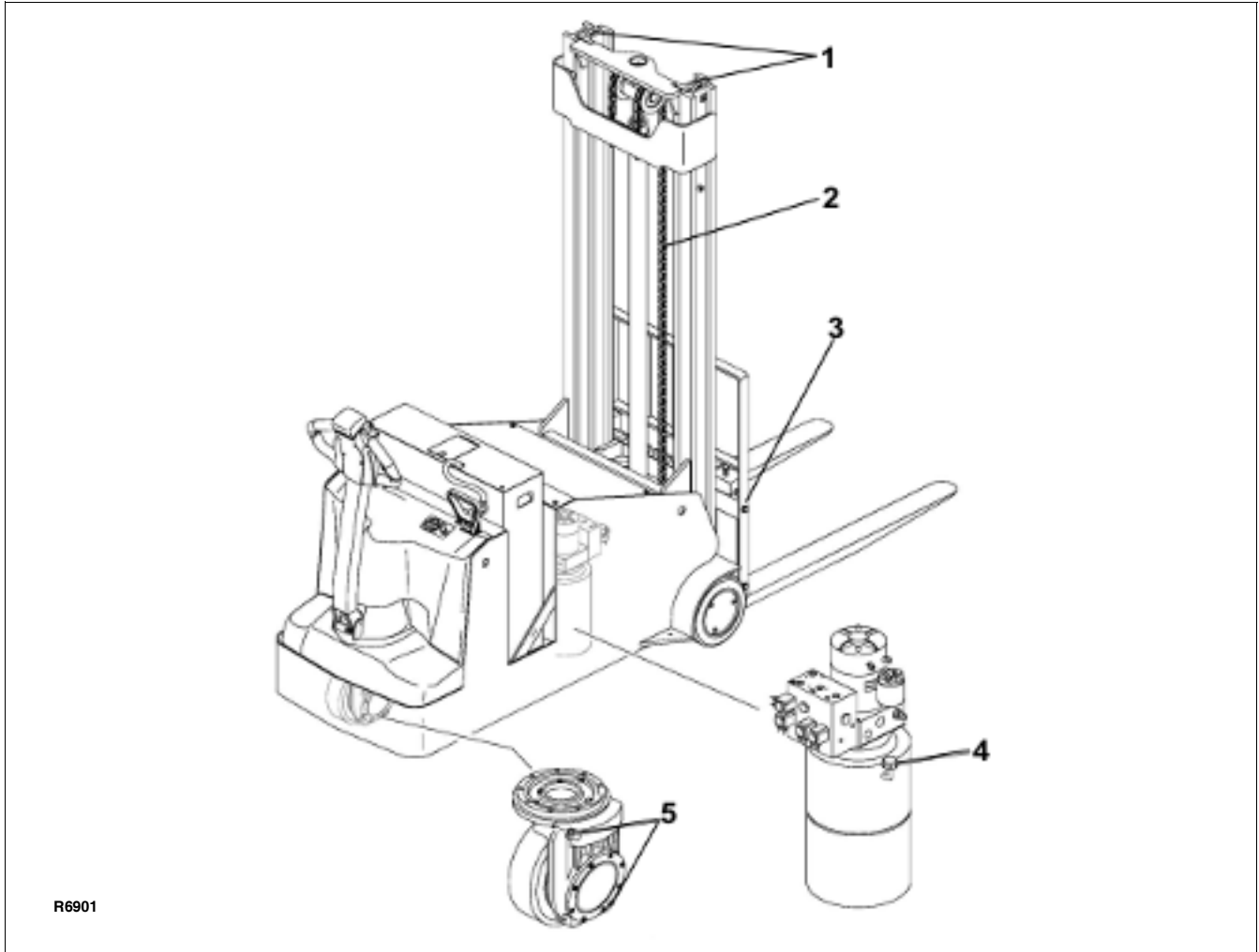

R6901

Figure 3-1 Lubrication Diagram

Table 3-3 Lubrication Chart

FIG 3-1 INDEX NO.	LOCATION	METHOD OF APPLICATION	TYPE (Table 3-3)	APPLICATION OF LUBRICANT
1	Inner & Outer Mast	Brush	No. 2	Full length of channel where rollers operate.
2	Lift Chain	Brush or Spray	No. 4	See Paragraph 3-6.
3	Lift Carriage	Brush	No. 2	Light coating where forks slide
4	Hydraulic Reservoir Capacity-1 quarts	Can	No. 3	With lift carriage fully lowered, fill reservoir with hydraulic oil to 1 inch below opening
5	Transmission Capacity 2 pints	Can	No. 1	Fill to level plug opening

NOTES

SECTION 4 TROUBLESHOOTING

4-1. GENERAL

Use [Table 4-1](#) as a guide to determine possible causes of trouble. The table is divided into five main categories: Truck and Hydraulic System Will Not

Operate: Truck Does Not Operate Forward or Reverse: Trouble With Braking: Trouble With Lifting Or Lowering, and Miscellaneous malfunctions.

Table 4-1 Troubleshooting Chart

MALFUNCTION	PROBABLE CAUSE	CORRECTIVE ACTION
<p>TRUCK AND HYDRAULIC SYSTEM WILL NOT OPERATE</p> <p>Truck will not travel nor will lift system operate.</p>	<p>a. Fuse (16, Figure 12-23) blown.</p> <p>b. Battery dead or disconnected.</p> <p>c. Keyswitch (6, Figure 12-22) defective.</p> <p>d. Defective wiring.</p>	<p>Check fuse and replace if necessary.</p> <p>Check battery quick-disconnect plug and check battery voltage.</p> <p>Bypass keyswitch to determine if it is malfunctioning.</p> <p>Check for open circuit. Repair as required.</p>
<p>TRUCK DOES NOT OPERATE FORWARD OR REVERSE</p> <p>Truck does not travel forward or reverse. All other functions operate normally.</p> <p>Truck travels forward but not in reverse.</p> <p>Truck travels reverse but not in forward.</p> <p>Truck travels forward and in reverse at lower speeds; will not travel at high speed.</p>	<p>a. Check all wiring. A loose connection may be the cause of malfunction.</p> <p>b. Defective deadman switch (29, Figure 12-1).</p> <p>c. Defective main contactor (10, Figure 12-23).</p> <p>d. Defective potentiometer (15, Figure 12-2).</p> <p>Defective potentiometer (15, Figure 12-2) in control head.</p> <p>Defective potentiometer (15, Figure 12-2) in control head.</p> <p>Defective potentiometer (15, Figure 12-2) in control head.</p>	<p>Tighten all loose connections before further troubleshooting.</p> <p>Check and replace switch if defective.</p> <p>Check for proper operation and replace if necessary.</p> <p>Check and replace potentiometer if defective.</p> <p>Check and replace potentiometer if defective.</p> <p>Check and replace potentiometer if defective.</p>
<p>TROUBLE WITH BRAKING</p> <p>Truck does not slow with brake, or brake does not engage.</p>	<p>a. Defective deadman switch (29, Figure 12-1).</p> <p>b. Defective electric brake (1, Figure 12-5).</p>	<p>Check deadman switch for continuity. If none found when the control arm is in the brake position, replace switch.</p> <p>Replace brake.</p>

Table 4-1 Troubleshooting Chart - Continued

MALFUNCTION	PROBABLE CAUSE	CORRECTIVE ACTION
<p>TROUBLE WITH BRAKING - Continued</p> <p>Brake will not release.</p> <p>Brake drags.</p> <p>Brake grabs.</p> <p>Abnormal noise and chatter when brake is applied.</p>	<p>a. Defective electric brake (1, Figure 12-5).</p> <p>b. Brake temperature above 281° F (140° C).</p> <p>c. Open brake circuitry or wiring.</p> <p>Defective electric brake (1, Figure 12-5).</p> <p>Defective electric brake (1, Figure 12-5).</p> <p>Defective electric brake (1, Figure 12-5).</p>	<p>Replace brake.</p> <p>Allow to cool.</p> <p>Make voltage checks.</p> <p>Replace.</p> <p>Replace.</p> <p>Replace.</p>
<p>TROUBLE WITH LIFTING OR LOWERING</p> <p>Oil sprays or flows from the top of the lift cylinder.</p> <p>Squealing sounds when lifting forks.</p> <p>Forks do not lift to top.</p> <p>Weak, slow or uneven action of hydraulic system.</p> <p>Forks do not lift, pump motor does not run.</p> <p>Forks do not lift, motor runs.</p>	<p>Defective packing in lift cylinder</p> <p>a. Oil level too low.</p> <p>b. Dry channels in mast.</p> <p>c. Defective mast or carriage rollers</p> <p>a. Oil level too low.</p> <p>b. Load larger than capacity.</p> <p>a. Defective pump or relief valve.</p> <p>b. Worn lift cylinder.</p> <p>c. Load larger than capacity.</p> <p>d. Defective lift motor solenoid.</p> <p>e. Battery charge low.</p> <p>a. Battery is dead or disconnected.</p> <p>b. Defective wiring.</p> <p>c. Defect in electrical system for operating pump motor.</p> <p>Defect in hydraulic system.</p>	<p>Repair lift cylinder.</p> <p>Identify oil leak.</p> <p>Apply grease.</p> <p>Replace rollers</p> <p>Add oil to reservoir.</p> <p>Refer to I.D.plate for capacity.</p> <p>Check pressure. Adjust as necessary.</p> <p>Replace cylinder.</p> <p>Refer to I.D.plate for capacity.</p> <p>Replace coil (9, Figure 12-14).</p> <p>Charge battery.</p> <p>Check and recharge if required.</p> <p>Check and repair as required.</p> <p>Check lift switch in control head, as well as the coil (9, Figure 12-14).</p> <p>Check the oil level in the reservoir and the oil lines to the lift cylinder, and repair as required. If normal, check the hydraulic pump, and relief valve. Repair, or adjust.</p>

Table 4-1 Troubleshooting Chart - Continued

MALFUNCTION	PROBABLE CAUSE	CORRECTIVE ACTION
<p>TROUBLE WITH LIFTING OR LOWERING - Continued</p> <p>Forks lift, but will not go down.</p> <p>Load will not hold</p>	<p>Defect in hydraulic system</p> <p>a. Oil bypassing internally in control valve</p> <p>b. Worn lift cylinder.</p>	<p>Check lowering control switch in control head, lowering relays (15 & 16, Figure 12-22) & lowering solenoid (20, Figure 12-14). Replace as required.</p> <p>Replace or repair valve assembly (21, Figure 12-14).</p> <p>Replace cylinder.</p>
<p>Platform does not lift to top. Pump motor runs.</p> <p>Forks creep downward under load when in a raised position.</p>	<p>a. Oil level too low.</p> <p>b. Load larger than capacity.</p> <p>c. Batteries need charging.</p> <p>Leak in hydraulic system, lift cylinder or lowering valve.</p>	<p>Add oil to reservoir.</p> <p>Refer to nameplate on side of mast for maximum load capacity.</p> <p>Change batteries.</p> <p>Check for leaking fitting in hydraulic line and repair as required. Repack lift cylinder or replace or repair valve assembly (21, Figure 12-14).</p>
<p>MISCELLANEOUS</p> <p>Steering arm does not return to the upright position.</p> <p>Truck moves forward when arm is pulled down.</p> <p>Steering arm jerks excessively starting or stopping the truck.</p> <p>Drive motor is jerky.</p>	<p>a. Weak return spring.</p> <p>b. Binding.</p> <p>a. Belly-button switch defective.</p> <p>b. Short in control head.</p> <p>Drive wheel worn.</p> <p>Motor internally damaged or worn.</p>	<p>Replace spring.</p> <p>Check and free the binding item. Verify that the cable has not been damaged. Repair or replace as needed.</p> <p>Check for short, and repair or replace as necessary.</p> <p>Check wiring and repair as required.</p> <p>Replace drive wheel if worn to within 3/8 inch of hub.</p> <p>Replace motor.</p>

4-2. CONTROLLER TROUBLESHOOTING

4-2.1. Zapi Handset

A Zapi Handset is available that is designed specifically for use with the Zapi controller. It serves multiple functions of reading diagnostic data, testing truck operation, setting options, adjustments and parameter changes of the controller. The Zapi Handset is available through your Blue Giant dealer. If you require dealer location information, contact Blue Giant.

Remove the rubber plug from the CNC connector of the controller [Figure 4-1](#) and plug in the Zapi Handset connector.

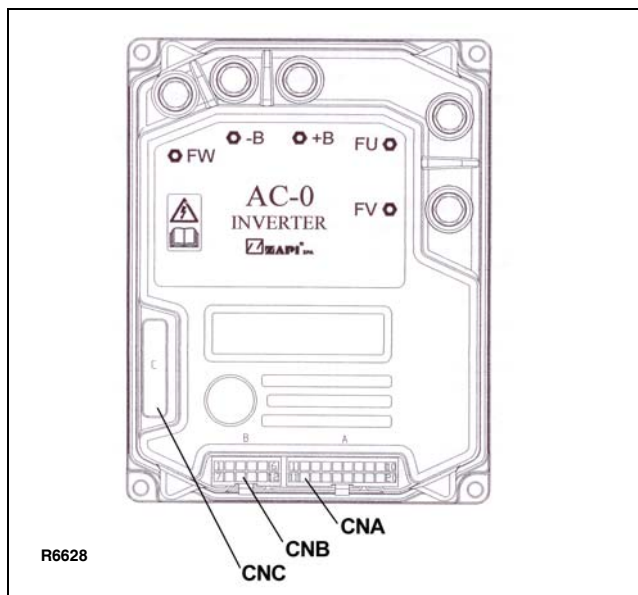

Figure 4-1. Zapi Controller

4-2.2. Fault Detection.

4-2.2.1. General

The controller provides diagnostics information to assist technicians in troubleshooting problems. When a fault is detected, an alarm is recorded in the logbook. It has a FIFO (First Input First Output) structure that means the oldest alarm is lost when the database is full and a new alarm occurs. The logbook is composed of alarms with the following information:

- The alarm code

- The times that each alarm occurs consecutively
- The Hour Meter value when the latest event of every alarm occurred
- The invert temperature when the latest event of every alarm occurred.

This function permits a deeper diagnosis of problems as the recent history can be revisited.

4-2.2.2. Logbook Access

To view the alarm logbook proceed as follows:

1. Connect the Zapi Handset, refer to paragraph [4-2.1](#).
2. Press the ROLL down button (1, [Figure 4-2](#)) and the ENTER button (3) at the same time to enter the MAIN MENU.
3. Press the ROLL down button (2) or the ROLL up button (1) to find the ALARMS display.
4. Press the ENTER button (3) to view the alarms.
5. Press the OUT button (6) to exit the alarms.

NOTE: Refer to bigjoesupport.com for the Zapi supplement containing detailed information on alarm codes. There are two versions shown. The BGL-22 uses the Standard version which lists the error by: Alarm Name, Repetitions, Temperature and Hour Meter reading.

4-2.3. Testing Truck Operation.

The Zapi Handset can be used to test certain truck operations as follows:

1. Connect the Zapi Handset, refer to paragraph [4-2.1](#).
2. Press the ROLL down button (1, [Figure 4-2](#)) and the ENTER button (3) at the same time to enter the MAIN MENU.
3. Press the ROLL down button (2) or the ROLL up button (1) to find the TESTER display.
4. Press the ENTER button (3) to view the tests.
5. To verify various switch functions, locate the switch on the display and then operate that function to verify operation
6. Press the OUT button (6) to exit the tests.

4-2.4. Settings and Adjustments

4-2.4.1. Set Options

To set options proceed as follows and refer to [Table 4-2](#):

1. Connect the Zapi Handset, refer to paragraph [4-2.1](#).
2. Press the ROLL up button (1, [Figure 4-2](#)) and the SET up button (5) at the same time to enter the CONFIG MENU.
3. Press the ROLL down button (1) or the ROLL up button (2) to find the SET OPTIONS display.
4. Press the ENTER button (3) to view the options.
5. Press the ROLL down (2) or the ROLL up button (1) to find the option to be changed.
6. Press the SET up button (5) or the SET down button (6) until the desired value setting is reached. The option is now set at the desired value.
7. Press the OUT button (4) to exit the options.

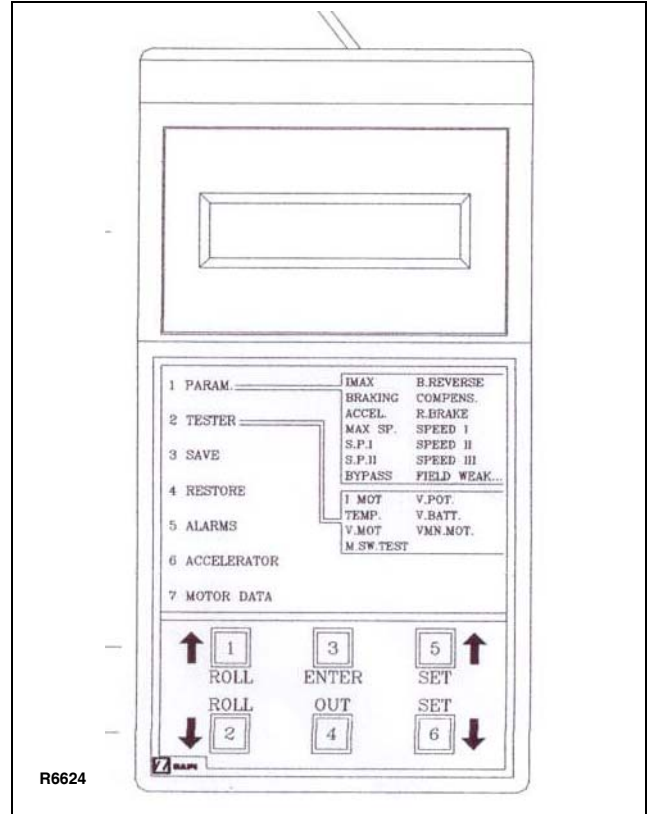

Figure 4-2. Zapi Handset

Table 4-2 Set Options

Parameter	Factory Setting	Description
TILLER switch	HANDLE	This option handles the input CNB#3 (Table 4-5). This input opens when the operator leaves the truck (released). It is connected to a Keyswitch controlled voltage when the operator is present.
SET INPUT #1	OPTION #1	<p>(Standard Version only). This option handles the digital input CNA#15. It can be can be set as:</p> <ul style="list-style-type: none"> • OPTION #1: CNA is managed as a cutback speed input (SR#1). • OPTION #2: CNA is managed as a digital handbrake input. • OPTION #3: CNA is managed as an inching backward. <p>The input CNA#15 (Table 4-5) can only be used as Aux Lowering request when the MDIPRC is PRESENT.</p> <p>This input must be connected to a Keyswitch controlled voltage. The SR#1 becomes active when CNA#15 (Table 4-5) is open. The inching backward becomes active when the CNA#15 (Table 4-5) is closed to a Keyswitch controlled voltage.</p>

Table 4-2 Set Options - Continued

Parameter	Factory Setting	Description
SET INPUT #2	PRESENT	<p>It can be can be set as:</p> <ul style="list-style-type: none"> • PRESENT: CNA#14 (Table 4-5) is managed as a cutback speed input (SR#2). • OPTION #1: CNA#14 (Table 4-5) is managed as an inching backward. <p>The input CNA#14 (Table 4-5) can only be used as Aux Lifting request when the MDIPRC is PRESENT.</p> <p>This input must be connected to a Keyswitch controlled voltage. The SR#2 becomes active when CNA#14 (Table 4-5) is open. The inching backward becomes active when the CNA#14 (Table 4-5) is closed to a Keyswitch controlled voltage.</p>
SET INPUT #4	OPTION #1	<p>This option handles the digital input CNB#7 (Table 4-5). It can be can be set as:</p> <ul style="list-style-type: none"> • BELLY CNB#7 (Table 4-5) is managed as a Belly Switch input. • BRAKE CNB#7 (Table 4-5) is managed as service brake input. This information can be used also to recognize when the operator is driving with a pressed pedal braking. • EX.HYDRO: CNB#7 (Table 4-5) is managed as Exclusive Hydro. This input must be connected to a Keyswitch controlled voltage. The Belly switch active level is specified on the QUICK INV LOGIC below. <p>The service brake of the exclusive hydro becomes active when CNB#7 is opened.</p>
HOUR COUNTER	RUNNING	<p>This option specifies the hour counter mode. It can be set as:</p> <ul style="list-style-type: none"> • RUNNING: The counter registers travel time only. • key on: The counter registers when the keyswitch is closed.
BATTERY CHECK	Level = 1	<p>This option specifies the handling of the low battery charge detection. It can be set as:</p> <ul style="list-style-type: none"> • Level 0: Nothing happens, the battery charge level is ignored. • Level 1: A BATTERY LOW alarm is raised when the battery level is calculated being less than 10% of the full charge. A BATTERY LOW alarm inhibits the Lifting function. • Level 2: A BATTERY LOW alarm is raised when the battery level is calculated being less than 10% of the full charge. A BATTERY LOW alarm reduces the maximum truck speed down to 24% of the full truck speed then, if the MDI-PRC is absent, inhibits the Lifting function. • Level 3 Equivalent to Level 1; a BATTERY LOW alarm is raised when the battery level is calculated being less than 10% of the full charge. A BATTERY LOW alarm inhibits the Lifting function.
HYDRO KEY ON	OFF	<p>ON/OFF: If this options is programmed ON the traction Inverter manages a hydraulic steering function when the keyswitch is switched ON (only if the AUX OUTPUT #1 option is programmed as HYDRO CONTACT or as WXCLUSIVE HYDRO).</p>
STOP ON RAMP	OFF	<p>Not used.</p>

Table 4-2 Set Options - Continued

Parameter	Factory Setting	Description
AUX OUTPUT #1	BRAKE	<p>This option handles output CNA#3 (Table 4-5). It can be used as:</p> <ul style="list-style-type: none"> • BRAKE: CNA#3 (Table 4-5) drives an electromechanical Brake. • HYDROCOMNT: CNA#3 (Table 4-5) drives the contractor for a hydraulic steering function when the direction input or brake pedal input are active or a movement of the truck is detected. • EX.HYDRO: CNA#3 (Table 4-5) drives the contractor for a hydraulic steering function when the exclusive hydro input is active. • FREE: CNA#3 (Table 4-5) is not used. <p>The current this output can sink is up to 3Adc.</p>
PEDAL BRAKING	NONE	<p>The analog input CNA#18 (Table 4-5) has one of two functions:</p> <ul style="list-style-type: none"> • Pedal Braking input. • Command input for lifting/lowering proportional valves in MDI-PRC version. <p>To turn from the first to the second function is just enough to set PEDAL BRAKING to HNONE.</p> <p>This option handles the analog input CNA#18 (Table 4-5) when used as pedal braking input:</p> <ul style="list-style-type: none"> • ANALOG: With this setting it is possible to modulate the strength of the braking when the accelerator is released. The strength of the braking is proportional to the brake pedal potentiometer connected to this input. When the pedal potentiometer voltage is equal/less than the SET POT BRK MIN, the minimum release braking strength is applied (following the RELEASE BRAKING setting). <p>When the pedal potentiometer voltage is equal/higher than the SET POT BRK MAX, the maximum release braking strength is applied (following the PEDAL BRAKING setting). In the intermediate position, the electrical braking strength is a linear function between the minimum (RELEASED BRAKING) and maximum (PEDAL BRAKING) intensity. When there is also a switch connected to the pedal braking (i.e. SET INPUT #4 to level BRAKE), it must be closed, otherwise the release braking is stuck to the minimum strength disregarding the pedal potentiometer position.</p> <ul style="list-style-type: none"> • DIGITAL: No pedal potentiometer is expected. Only when both the SET INPUT #4 is Level BRAKE and the brake switch connected to CNB#4 (Table 4-5) is closed, the release electrical braking follows the PEDAL BRAKING setting (maximum strength); in all of the other conditions the release electrical braking follows the RELEASE BRAKING setting (minimum strength). • NONE: The analog input CNA#18 (Table 4-5) is not used for the release braking modulation.
QUICK INVERSION	BELLY	<p>This option specifies the quick inversion mode when the SET INPUT #4 is set BELLY. It can be set as:</p> <ul style="list-style-type: none"> • NONE: The quick inversion function is not managed (no effect when CNB#7 (Table 4-5) switches over). • TIMED: The quick inversion function is timed. • BELLY: The quick inversion function is managed but not timed.

Table 4-2 Set Options - Continued

Parameter	Factory Setting	Description
AUX VOLTAGE #1	100%	This option specifies the percentage of the keyswitch controlled voltage to be applied to the loads on CNA#1 (Table 4-5) (main contactor coil) and CNA#3 (Table 4-5) (electromechanical brake). The voltage modulation is set with a PWM at 1 kHz frequency. After an initial delay of about 1 sec in which the entire keyswitch controlled voltage is applied to the loads, the PWM reduces the voltage at the loads down to the specified percentage.
PERFORMANCE	OPTION #1	This option can be set <ul style="list-style-type: none"> • OPTION#1 • OPTION#2
QUICK INV. LOGIC	OPTION #1	This option specifies the active level for the Belly switch input (CNB#7) <ul style="list-style-type: none"> • OPTION#1: The quick inversion is executed when CNB#7 (Table 4-5) is closed to a Keyswitch controlled voltage. • OPTION#2: The quick inversion is executed when CNB#7 (Table 4-5) is opened from a Keyswitch controlled voltage.
MDI-PRC	ABSENT	This option specifies: <ul style="list-style-type: none"> • PRESENT: The MDI-PRC is connected to the ACO via the CAN Bus: the handling of the Hydraulics is specified on the TRUCK TYPE setting. • ABSENT: The MDI-PRC is not connected to the ACO: the TRUCK TYPE disappears from the SET OPTIONS function list.
MOT SET-UP	OFF	Not used.

4-2.4.2. Adjustments

To change an adjustment proceed as follows and refer to [Table 4-3](#):

1. Connect the Zapi Handset, refer to paragraph 4-2.1.
2. Press the ROLL up button (1, [Figure 4-3](#)) and the SET up button (5) at the same time to enter the CONFIG MENU.
3. Press the ROLL down button (1) or the ROLL up button (2) to find the ADJUSTMENTS display.
4. Press the ENTER button (3) to view the adjustments.
5. Press the ROLL down button (2) or the ROLL up button (1) to find the adjustment to be changed.
6. Press the SET up button (5) or the SET down button (6) until the desired value setting is reached. The adjustment is now set at the desired value.
7. Press the OUT button (4) to exit the adjustments.

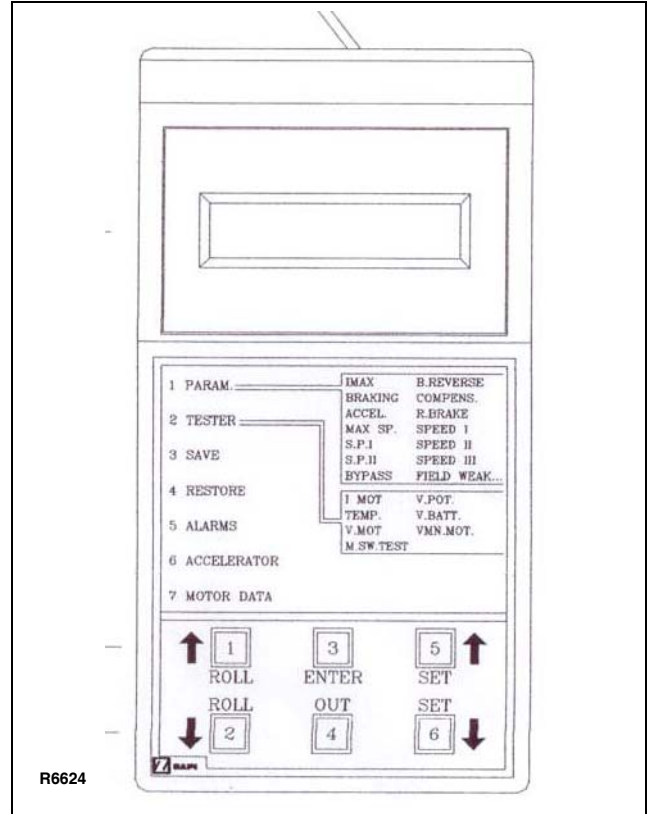

Figure 4-3 Zapi Handset

Table 4-3 Adjustments

Parameter	Factory Setting	Description
SET POT BRK MIN	0.5 V	This setting records the minimum value of braking pedal potentiometer when the braking pedal switch is closed; the procedure is similar to the PROGRAM VACC function. This procedure must be carried out only if the PEDAL BRAKING option is programmed as ANALOG. No adjustment is necessary when PEDAL BRAKING options is programmed as NONE.
SET POT BRK MAX	4.5 V	This setting records the maximum value of braking pedal potentiometer when the braking pedal is fully pressed; the procedure is similar to the PROGRAM VACC function. This procedure must be carried out only if the PEDAL BRAKING option is programmed as ANALOG. No adjustment is necessary when PEDAL BRAKING options is programmed as NONE.
SET BATTERY TYPE	24V	Selects the nominal battery voltage.
ADJUST BATTERY	XX V	Do not modify - Factory adjusted (Fine adjustment of the battery voltage measured by the controller.)
THROTTLE 0 ZONE	9%	Establishes a deadband in the accelerator input curve.

Table 4-3 Adjustments - Continued

Parameter	Factory Setting	Description
THROTTLE X POINT	45%	This parameter together with the THROTTLE Y POINT, changes the characteristic of the accelerator input curve: when the accelerator is de-pressed to X point percent, the corresponding truck speed is Y point percent of the Maximum truck speed. The relationship between the accelerator position and the truck speed is linear between the THROTTLE 0 ZONE and the X point and also between the X point and the maximum accelerator position but with two different slopes (Figure 4-4).
THROTTLE Y POINT	68%	This parameter together with the THROTTLE X POINT, changes the characteristic of the accelerator input curve: when the accelerator is de-pressed to X point percent, the corresponding truck speed is Y point percent of the Maximum truck speed. The relationship between the accelerator position and the truck speed is linear between the THROTTLE 0 ZONE and the X point and also between the X point and the maximum accelerator position but with two different slopes (Figure 4-4).
ADJUSTMENT #01	LEVEL = 5	Adjust the upper level of the battery charge table (Level 0 to 9).
ADJUSTMENT #02	LEVEL = 5	Adjust the lower level of the battery charge table (Level 0 to 9).
LOAD HM FROM MDI	OFF	When set On, the Hourmeter of the Controller is transferred and recorded on the Hourmeter of the Standard MDI (connected on the Serial Link).
CHECK UP DONE	OFF	Turn it On when asked Maintenance service has been executed to cancel the CHECK UP NEEDED warning.
CHECK UP TYPE	NONE	It specifies the handling of the CHECK UP NEEDED warning: <ul style="list-style-type: none"> • NONE: No CHECK UP NEEDED warning. • OPTION#1: CHECK UP NEEDED warning on the handset and MDIPRC after 300 hours. • OPTION#2: Equal to OPTION#1 but Speed reduction after 340 hours. • OPTION#3: Equal to OPTION#2 but the truck definitively stops after 380 hours.

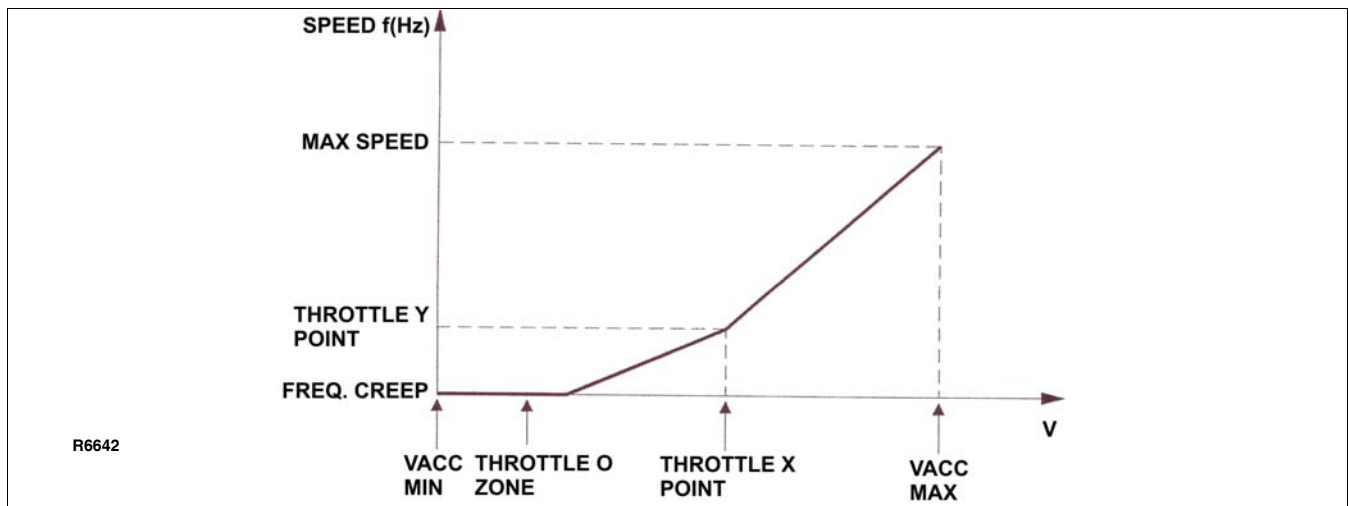

Figure 4-4 Throttle Regulation

4-2.4.3. Parameter Change

To change a parameter proceed as follows and refer to [Table 4-4](#):

1. Connect the Zapi Handset, refer to paragraph 4-2.1.
2. Press the ROLL down button (1, [Figure 4-5](#)) and the ENTER button (3) at the same time to enter the MAIN MENU.
3. Press the ROLL down button (1) or the ROLL up button (2) to find the PARAMETER CHANGE display.
4. Press the ENTER button (3) to view the parameters.
5. Press the ROLL down button (2) or the ROLL up button (1) to find the parameter to be changed.
6. Press the SET up button (5) or the SET down button (6) until the desired value setting is reached. The parameter is now set at the desired value.
7. Press the OUT button (4) to exit the parameters.

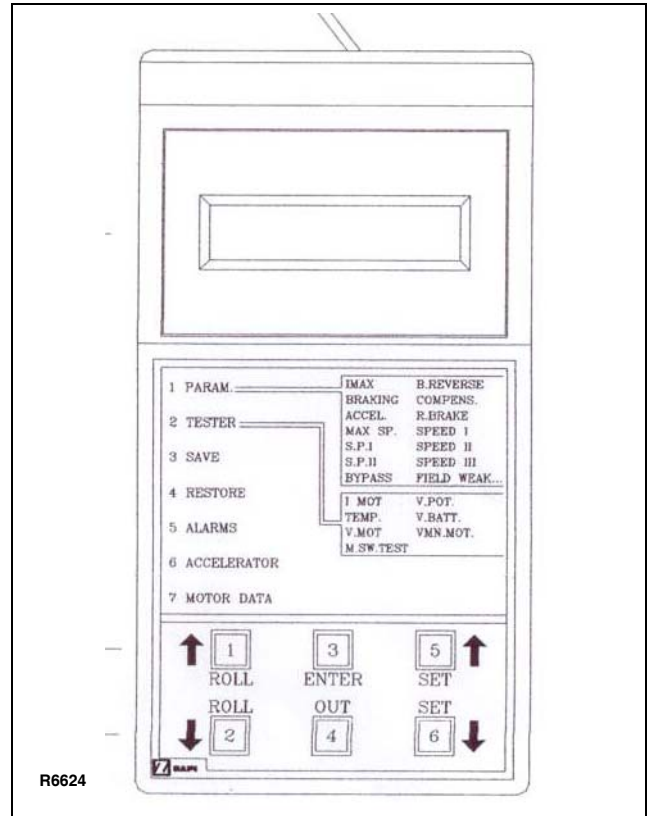

Figure 4-5 Zapi Handset

Table 4-4 Parameter Adjustments

Parameter	Factory Setting	Description
ACCELER. DELAY	LEVEL = 8	Level 0 to 9. It determines the acceleration ramp. At Level 9 the truck takes a long time to accelerate.
RELEASE BRAKING	LEVEL = 5	Level 0 to 9. It controls the deceleration ramp when the travel request is released. At Level 9 the truck brakes abruptly.
INVERS. BRAKING	LEVEL = 4	Level 0 to 9. It controls the deceleration ramp when the direction switch is inverted during travel. At Level 9 the truck brakes abruptly.
PEDAL BRAKING	LEVEL = 9	Level 0 to 9. It controls the deceleration ramp when the travel request is released and the brake pedal switch is pressed to its maximum. At Level 9 the truck brakes abruptly.
SPEED LIMIT BRK	LEVEL = 1	Level 0 to 9. It controls the deceleration ramp when the accelerator has turned down but not completely released. At Level 9 the truck decelerates abruptly.
BRAKE CUTBACK	LEVEL = 5	Level 0 to 9. It controls the deceleration ramp when the a speed reduction input becomes active and the motor slows down. At Level 9 the truck decelerates abruptly.
MAX SPEED FORW	100 Hz	Typically from 90 Hz to 160 Hz. It determines the maximum speed in forward direction.
MAX SPEED BACK	100 Hz	Typically from 90 Hz to 160 Hz. It determines the maximum speed in backward direction.

Table 4-4 Parameter Adjustments - Continued

Parameter	Factory Setting	Description
CUTBACK SPEED	100%	Typically from 10% to 100%. It determines the percentage of the max speed applied when the cutback switch 1 (SR#1 on CNA#15 (Table 4-5) is active. When set to 100% the speed reduction is ineffective.
CUTBACK SPEED 2	37%	Typically from 10% to 100%. It determines the percentage of the max speed applied when the cutback switch 2 (SR#2 on CNA#14 (Table 4-5) is active. When set to 100% the speed reduction is ineffective.
HS CUTBACK	100%	Typically from 10% to 100%. It determine the percentage of the max speed applied when the Hard & Soft function (H&S switch on CNB#4 (Table 4-5) is active. When set to 100% the speed reduction is ineffective.
FREQUENCY CREEP	5.00 Hz	Hz value. This is the minimum speed applied when the forward or reverse switch is closed, but the accelerator at its minimum. In the ACO sense Coils this setting is higher equal than 5 Hz.
RPM CREEP	100%	A Percentage value. Set to 100% and not Used.
MAXIMUM CURRENT	96%	It specifies the percentage of the absolute current (150A) at which the current will be limited. Normally MAXIMUM CURRENT is 100%. DO NOT CHANGE.
INCHING SPEED	0 Hz	Hz value. It determines the speed when the “Inching function” is active.
INCHING TIME	LEVEL = 0	Level 0 to 9. It determines the duration time when the “Inching function” is active.
AUXILIARY TIME	1	Time units value (seconds). For the encoder version, it determines the time duration (in seconds) in which the the frequency was arrived to zero.
ANTIROLLBACK	80%	A Percentage of the Maximum Current. This setting increases the phase current when low frequency during starting operation. It is used to push up, in feedforward way, the torque when it is not possible to control the flux, in feedback way, because of the low frequency.

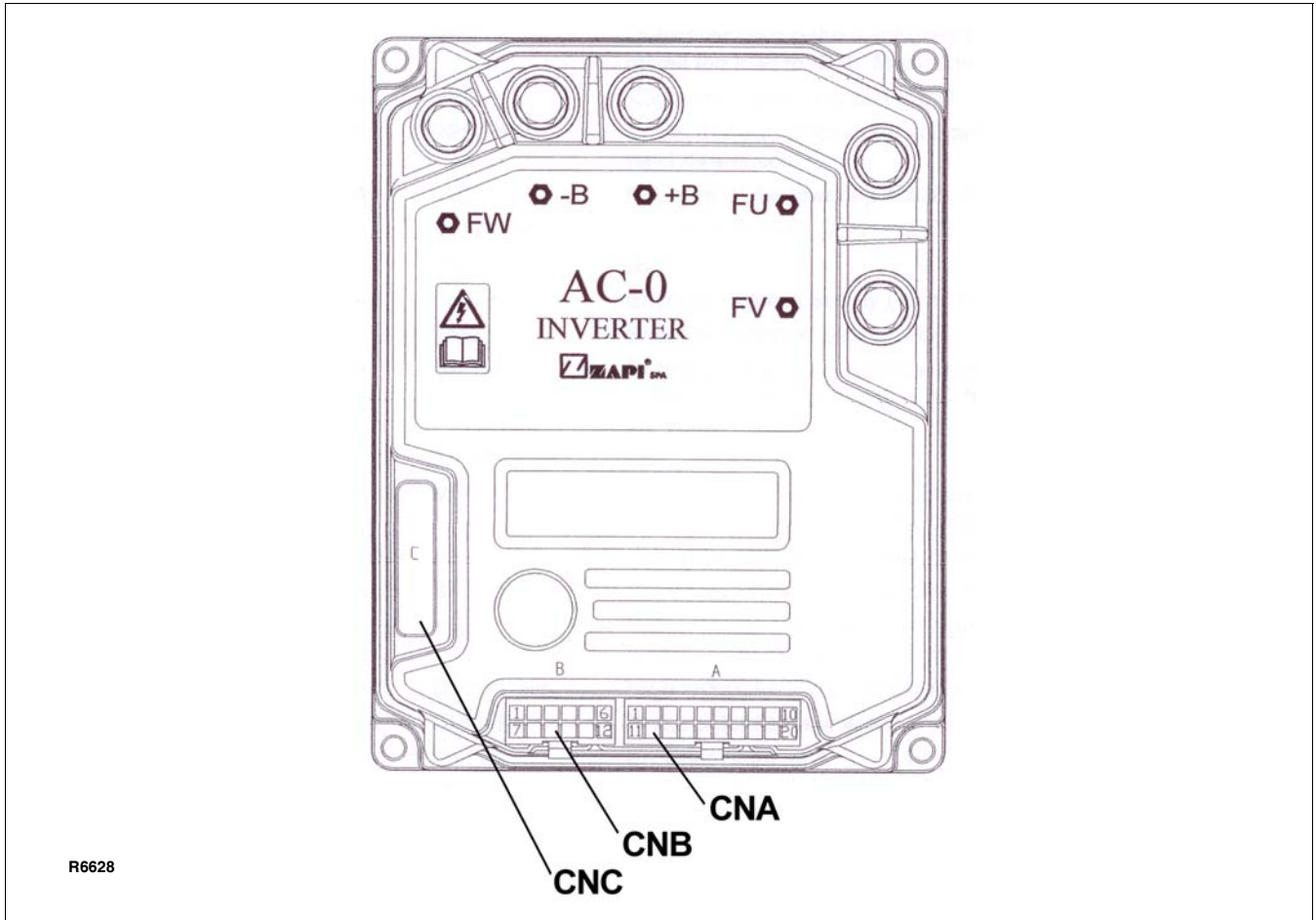

Figure 4-6 Zapi Controller Connections

Table 4-5 Zapi Controller Connector Pins

CNA Connector		
PIN	ABBREVIATION	DESCRIPTION
CNA#1	NMC	Negative of main contactor coil.
CNA#2	PMC	Positive of main contactor coil.
CNA#3	NEB	Output for driving the electromechanical brake coil; drives the load to -Batt. Maximum current: 3 A.
CNA#4	NPC	Negative of pump contactor soil.
CNA#5	PPC/PEV	Positive of pump contactor coil and lowering electrovalve coil.
CNA#6	NEV	Negative of the lowering electrovalve coil.
CNA#7	CAN LOW	Low level CAN-BUS voltage I/O.
CNA#8	-BAT	-Bat.
CNA#9	ENC+	Encoder Positive Supply (+5 or +12 Vdc)
CNA#10	ENC-	Encoder Negative Supply (GND to minus battery)
CNA#11	HM(+B)	Output for driving an hourmeter; when the hourmeter is active this output provides a +Batt signal; 3 maximum current.

Table 4-5 Zapi Controller Connector Pins - Continued

CNA Connector - Continued		
PIN	ABBREVIATION	DESCRIPTION
CNA#12	-BATT	-Batt.
CNA#13	MOT TH	Motor thermal sensor input. The internal pull-up is a fixed 2mA (Max 5V) source current.
CNA#14	SR2	Speed reduction 2 input. Active low (switch opened).
CNA#15	SR1	Speed reduction 1 input. Active low (switch opened).
CNA#16	+12V	This output provides a +12V signal for the MDI PRC, it present; mA maximum current.
CNA#17	CAN HIGH	High level CAN-BUS voltage I/O.
CNA#18	CPOTB	Brake potentiometer wiper.
CNA#19	ENC A	Encoder Channel A.
CNA#20	ENC B	Encoder Channel B.
CNB Connector		
CONNECTOR PIN	ABBREVIATION	DESCRIPTION
CNB#1	KEY SW	Connected to the power supply through a microswitch (KEY) with a 6.3-10 A fuse in series (this could be mounted on the AC-0 cover).
CNB#2	CM	Common for FW/BW/SR1/SR2/TILLER/H&S/BELLY/LIFTING/ LOWERING microswitches. This connection supplies a keyswitch voltage level.
CNB#3	TILLER SW	Tiller request input. Must be connected to the tiller microswitch, active high.
CNB#4	H&S SW	Hard & Soft request input. Must be connected to the Hard & Soft microswitch, active high.
CNB#5	BACKWARD SW	Backward direction request input. Must be connected to the backward direction microswitch, active high.
CNB#6	FORWARD SW	Forward direction request input. Must be connected to the forward direction microswitch, active high.
CNB#7	BELLY SW	Quick inversion function input; must be connected to the Belly microswitch; it is active high.
CNB#8	LOWERING SW	Lowering request input, active high.
CNB#9	LIFTING SW	Lifting request input, active high.
CNB#10	CPOT	Lifting request input, active high.
CNB#11	NPOT	Negative of accelerator unit, tested for wire disconnection diagnosis.
CNB#12	PPOT	Potentiometer positive: 10V output; keep load >1kΩ.

Table 4-5 Zapi Controller Connector Pins - Continued

CNC Connector

CONNECTOR PIN	ABBREVIATION	DESCRIPTION
CNC#1	PCLRxD	Positive serial reception.
CNC#2	NCLRxD	Negative serial reception.
CNC#3	PCLTxD	Positive serial transmission.
CNC#4	NCLTxD	Negative serial transmission.
CNC#5	GND	Negative console power supply.
CNC#6	+12V	Positive console power supply.
CNC#7	FLASH	Must be connected to C8 for the Flash memory programming (if used).
CNC#8	FLASH	Must be connected to C7 for the Flash memory programming (If used).

NOTES

SECTION 5 STEERING ARM, CONTROL HEAD AND COMPARTMENT

5-1. CONTROL HEAD

5-1.1. Cap Assembly Removal.

1. Turn off the key switch (6, [Figure 12-22](#)) and disconnect the batteries.
2. Remove four screws (17, [Figure 5-1](#)), lift up cap assembly (21) and disconnect harness (23) from harness (28, [Figure 5-2](#)).

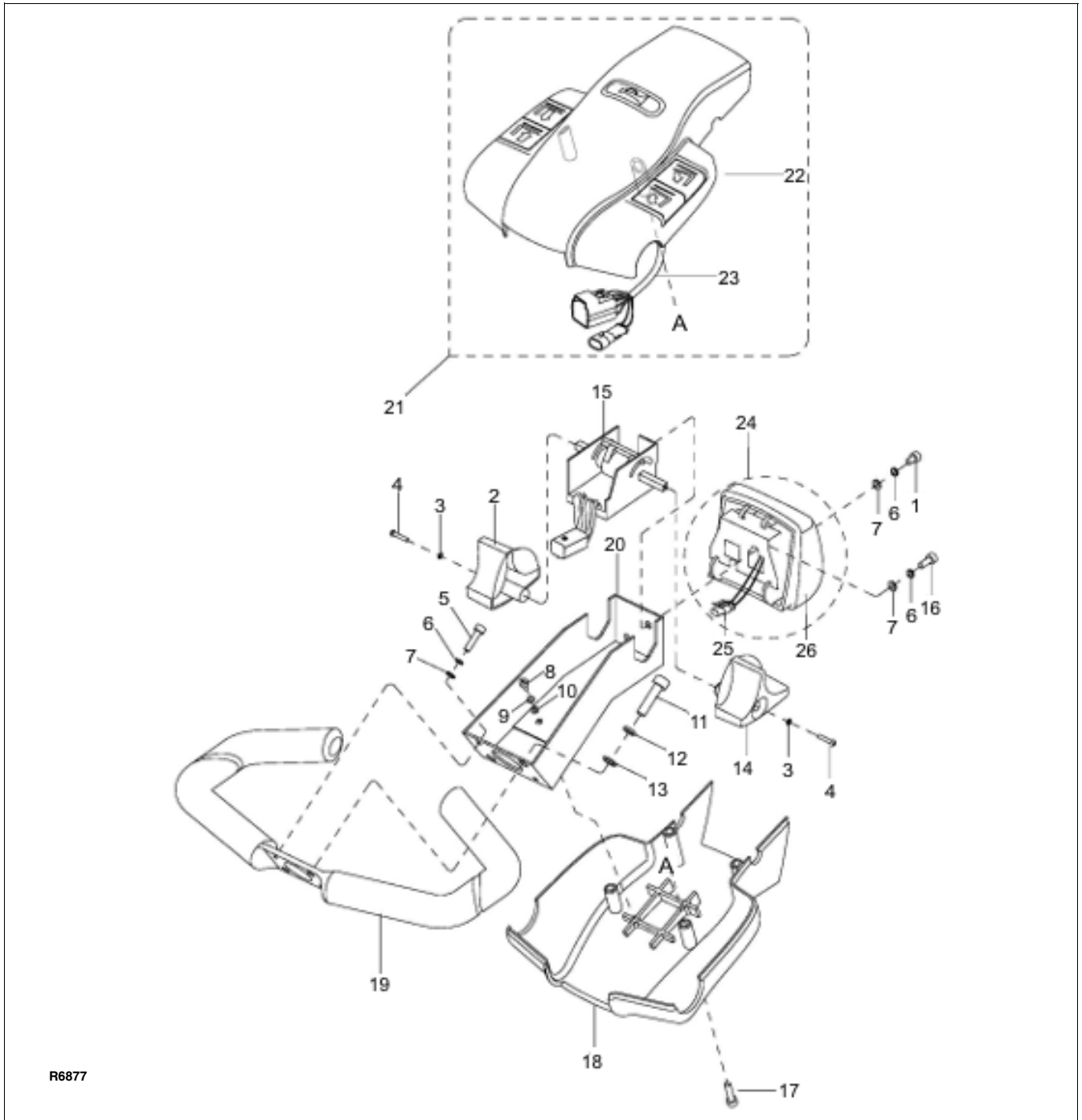

Figure 5-1 Control Head

R6877

5-1.2. Cap Assembly Installation.

1. Hold cap assembly (21, [Figure 5-1](#)) in place and connect harness (23) to harness (28, [Figure 5-2](#)).
2. Position cap assembly (21, [Figure 5-1](#)) on control head and secure with four screws (17).
3. Reconnect the batteries and turn on the key switch (6, [Figure 12-22](#)).

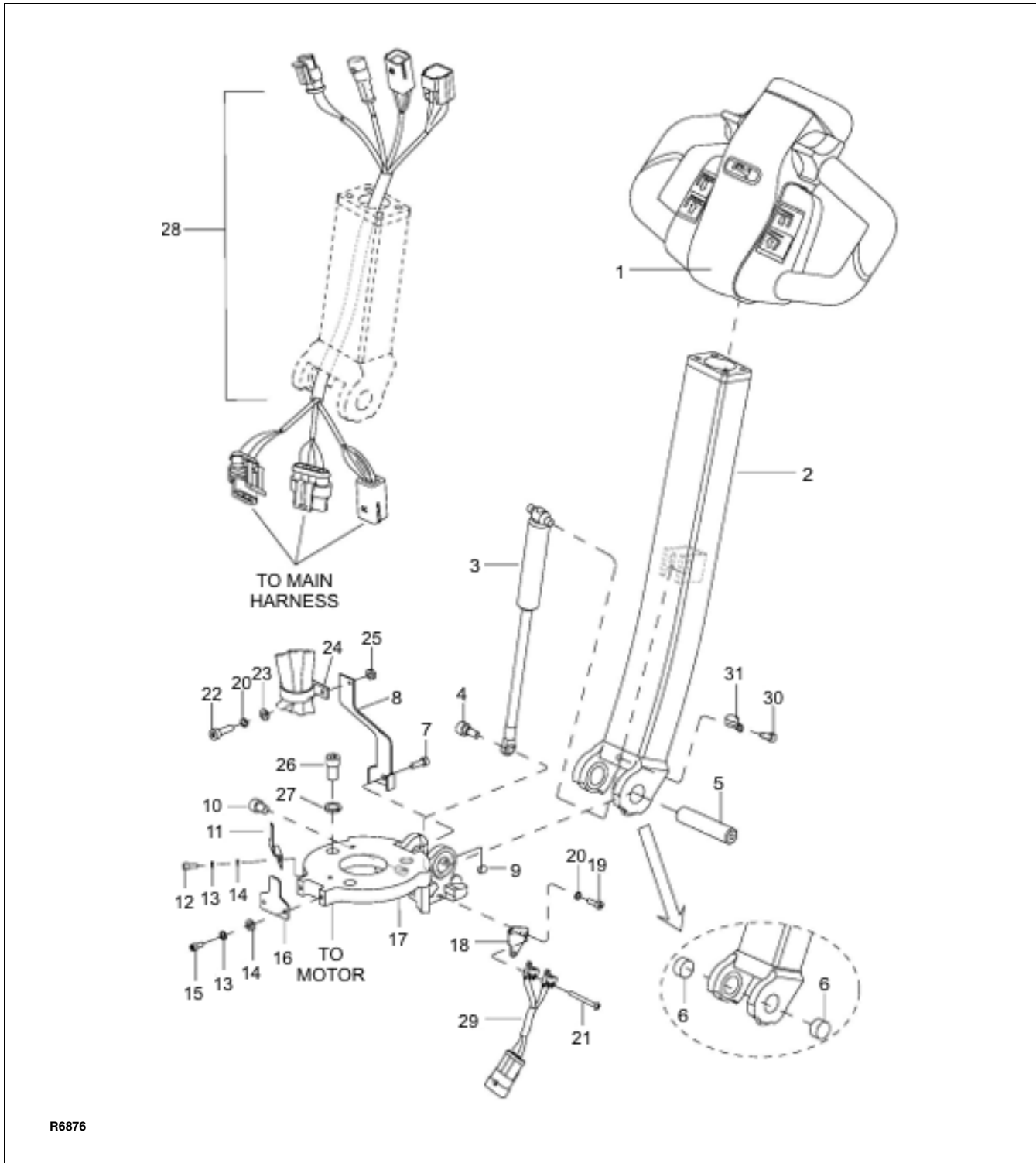

Figure 5-2 Steering Arm

5-1.3. Control Head Removal

1. Remove the cap assembly as described in paragraph 5-1.1.
2. Disconnect harness (28, [Figure 5-2](#)) from potentiometer (15, [Figure 5-1](#)) and reversing switch (24).
3. Remove two screws (11), two lock washers (12) and two flat washers (13).

WARNING: When removing the control head in the following steps, be sure to hold it in place until the control harness is disconnected.

4. Remove two screws (5), two washers (6) and two flat washers (7).
5. Remove the control head and handle (19).

5-1.4. Control Head Installation

1. Hold control head and handle (19, [Figure 5-1](#)) in place and install two screws (5), two washers (6) and two flat washers (7).
2. Install two screws (11), two lock washers (12) and two flat washers (13).
3. Reconnect harness (28, [Figure 5-2](#)) to potentiometer (15, [Figure 5-1](#)) and reversing switch (24).
4. Install the cap assembly as described in paragraph 5-1.2.

5-1.5. Speed Potentiometer Replacement.

1. Remove the cap assembly as described in paragraph 5-1.1.
2. Disconnect harness (28, [Figure 5-2](#)) from potentiometer (15, [Figure 5-1](#)).
3. Remove screw (4), washer (3) and control knob (2) from potentiometer (15).
4. Remove screw (4), washer (3) and control knob (14) from other side of potentiometer (15).
5. Remove screw (1), lock washer (6) and flat washer (7).
6. Remove screw (16), lock washer (6) and flat washer (7) and remove potentiometer (15) from bracket (20).
7. Position new potentiometer (15) in bracket (20) and secure with screw (16), lock washer (6) and flat washer (7).
8. Install screw (1), lock washer (6) and flat washer (7).

9. Install control knob (14) on potentiometer (15) and secure with screw (4), and washer (3).
10. Install control knob (2) on the other side of potentiometer (15) and secure with screw (4), and washer (3).
11. Connect harness (28, [Figure 5-2](#)) to potentiometer (15, [Figure 5-1](#)).
12. Install the cap assembly as described in paragraph 5-1.2.

5-1.6. Belly-Button Switch Replacement.

1. Remove the cap assembly as described in paragraph 5-1.1.
2. Disconnect harness (28, [Figure 5-2](#)) from reversing switch (25, [Figure 5-1](#)).
3. Remove screw (1), lock washer (6) and flat washer (7).
4. Remove screw (16), lock washer (6) and flat washer (7) and remove switch assembly (24) from bracket (20).
5. Remove pin (5, [Figure 5-3](#)), bracket (4), and spring (2) from button (1).
6. Remove two pins (3) and switch assembly (25, [Figure 5-1](#)) from bracket (4, [Figure 5-3](#)).
7. Position the new switch assembly (25, [Figure 5-1](#)) in bracket (4, [Figure 5-3](#)) and secure with two pins (3).
8. Position bracket (4) in button (1) and install pin (5).
9. Position switch assembly (24, [Figure 5-1](#)) on bracket (10) and secure with two screws (13).
10. Reconnect harness (28, [Figure 5-2](#)) to reversing switch (25, [Figure 5-1](#)).
11. Install the cap assembly as described in paragraph 5-1.2.

5-1.7. Horn Switch Replacement.

1. Remove the cap assembly as described in paragraph 5-1.1.
2. Remove three screws (11, [Figure 5-4](#)), bracket (14) and springs (13).
3. Remove two pins (12) and defective switch from bracket (14).
4. Unsolder harness from defective switch and connect it to the new switch.

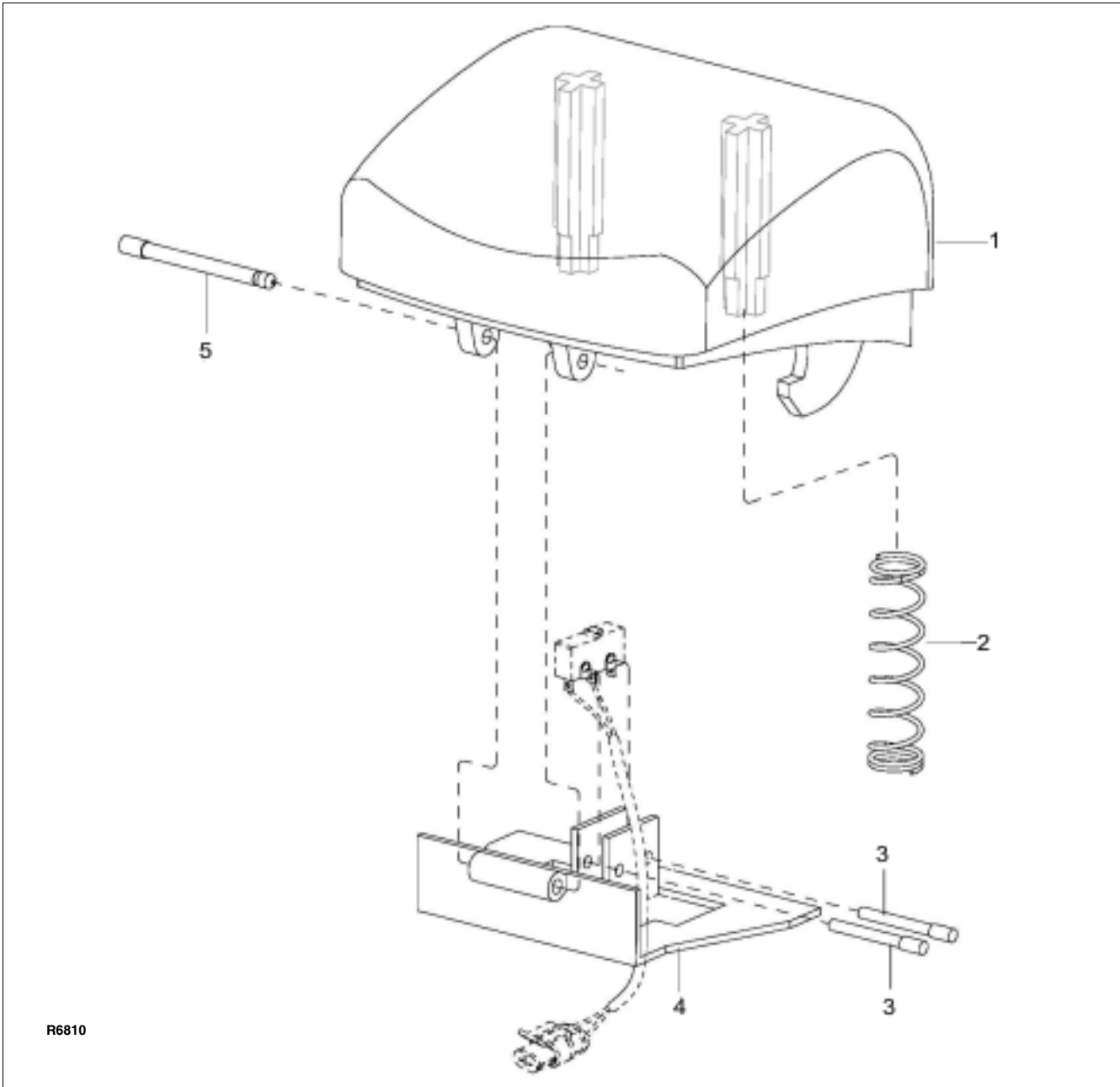
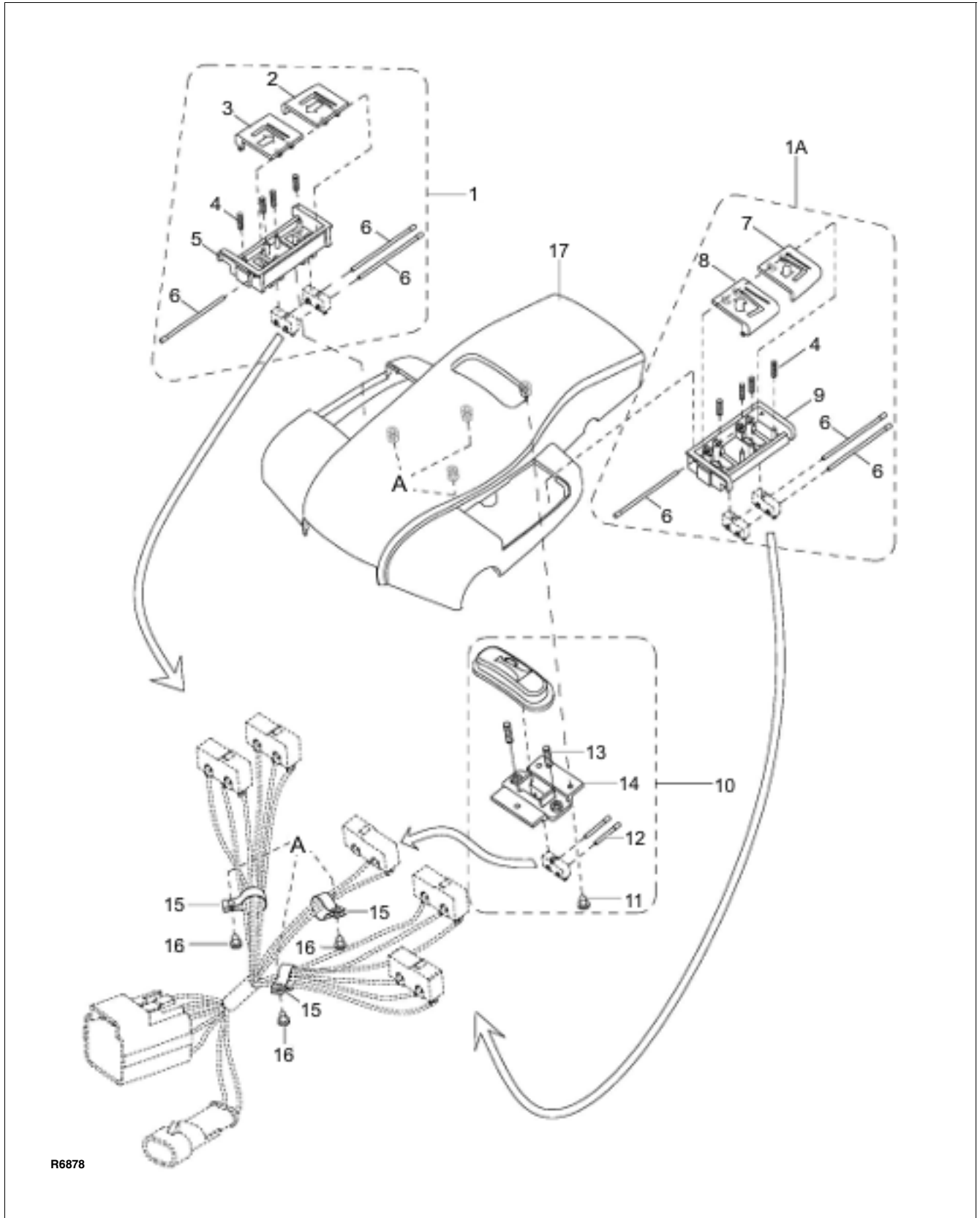

Figure 5-3 Emergency Reverse Switch Assembly

- | | |
|--|---|
| <ol style="list-style-type: none"> 5. Position the new switch in bracket (14) and secure with two pins (12). 6. Position bracket (14) in cover (17) and secure with three screws (11). 7. Install the cap assembly as described in paragraph 5-1.2. <p>5-1.8. Lift and Lower Switch Replacement.</p> <ol style="list-style-type: none"> 1. Remove the cap assembly as described in paragraph 5-1.1. | <ol style="list-style-type: none"> 2. Remove switch assembly (1, Figure 5-4) from cap (17). 3. Remove pin (6) securing bracket (5) and remove the bracket. 4. Remove two pins (6), two switches and four springs (4) from bracket (5). 5. Unsolder harness from defective switch. 6. Solder the harness to new switch. |
|--|---|



R6878

Figure 5-4 Cap Assembly

7. Position the new switches and four springs (4) in bracket (5) and secure with two pins (6).
8. Position switch assembly (1) in cover (17) and secure with pin (6).
9. Install the cap assembly as described in paragraph 5-1.2.

5-1.9. Tilt Switch Replacement.

1. Remove the cap assembly as described in paragraph 5-1.1.
2. Remove switch assembly (1A, Figure 5-4) from cap (17).
3. Remove pin (6) securing bracket (9) and remove the bracket.
4. Remove two pins (6), two switches and four springs (4) from bracket (9).
5. Unsolder harness from defective switch.
6. Solder the harness to new switch.
7. Position the new switches and four springs (4) in bracket (9) and secure with two pins (6).
8. Position switch assembly (1A) in cover (17) and secure with pin (6).
9. Install the cap assembly as described in paragraph 5-1.2.

5-2. STEERING ARM

5-2.1. Return Spring Replacement.

The steering arm gas return spring (3, Figure 5-2) is replaced while the steering arm (2) is in the upright position.

1. Turn off the key switch (6, Figure 12-22) and disconnect the batteries.
2. Remove two screws (4, Figure 12-6) and middle cover (5).
3. Secure the steering arm (2, Figure 5-2) in the upright position.
4. Remove screw (4) and free the gas return spring (6) from bracket (17).
5. Pull downward on the gas return spring (3) to free it from its seat inside steering arm (2).
6. Position the new gas return spring (3) inside the steering arm being sure it fully engages its seat.
7. Position the opposite end of the gas return spring (3) on bracket (17) and install screw (4).

8. Install middle cover (5, Figure 12-6) and secure with two screws (4).
9. Reconnect the batteries and turn on the key switch (6, Figure 12-22).

5-2.2. Steering Arm Removal.

1. Turn off the key switch (6, Figure 12-22) and disconnect the batteries.
2. Remove two screws (4, Figure 12-6) and middle cover (5).
3. Disconnect harness (28, Figure 5-2) from harness (1, Figure 12-25).
4. Attach a hoist to steering arm (2, Figure 5-2).
5. Remove screw (9), shaft (5) and the steering arm (2).

5-2.3. Steering Arm Installation.

1. Position steering arm (2, Figure 5-2) over the bracket (17) and secure with shaft (5) and screw (9).
2. Reconnect harness (28) from harness (1, Figure 12-25).
3. Install middle cover (5, Figure 12-6) and secure with two screws (4).
4. Reconnect the batteries and turn on the key switch (6, Figure 12-22).

5-3. COMPARTMENT COVERS

5-3.1. Removal.

1. Turn off the key switch (6, Figure 12-22) and disconnect the batteries.
2. Remove two screws (4, Figure 12-6) and middle cover (5).
3. Remove two screws (1), washers (2) and upper cover (3).
4. Remove lower cover (6).

5-3.2. Installation.

1. Install lower cover (6, Figure 12-6).
2. Install upper cover (3) and secure with two screws (1).
3. Install middle cover (5) and secure with two screws (4).
4. Reconnect the batteries and turn on the key switch (6, Figure 12-22).

SECTION 6 BRAKE SERVICING

6-1. BRAKES.

The brake system consists of a drive motor mounted brake. This brake is spring applied and electrically released.

6-1.1. Brake Assembly Replacement

1. Block load wheels.
2. Turn off the key switch (6, [Figure 12-22](#)) and disconnect the batteries.
3. Remove the rear compartment covers as described in paragraph [5-3](#).
4. Remove the steering arm as described in paragraph [5-2.2](#).
5. Disconnect electric brake (1, [Figure 6-1](#)) from the harness (1, [Figure 12-25](#)).
6. Remove three screws (2, [Figure 6-1](#)) and remove brake (1).
7. Place the new brake into position and secure with the three screws (2).
8. Reconnect electric brake (1) to the harness (1, [Figure 12-25](#)).
9. Install the steering arm as described in paragraph [5-2.3](#).
10. Install the rear compartment covers as described in paragraph [5-3](#).
11. Reconnect the batteries and turn on the keyswitch (6, [Figure 12-22](#)).

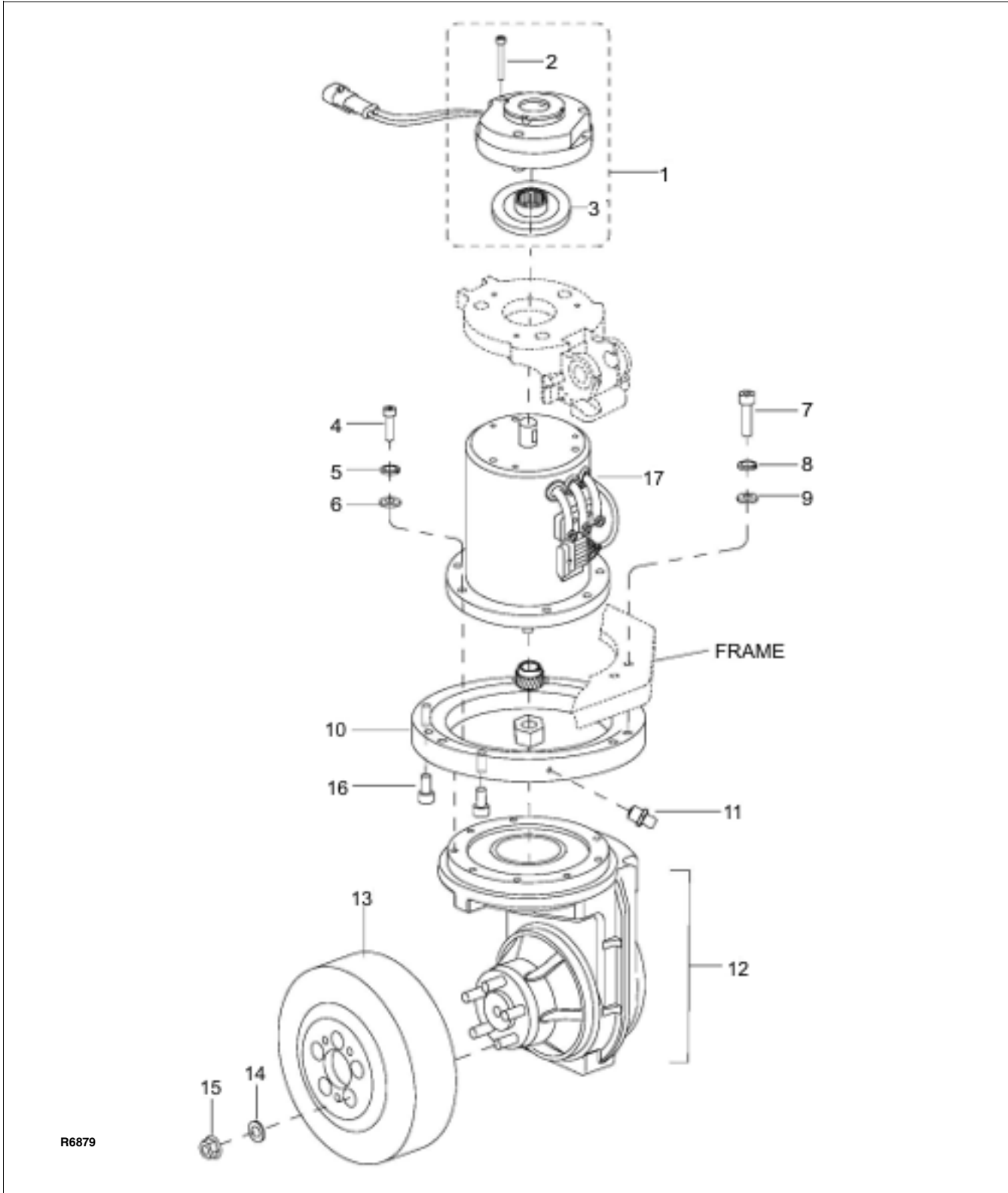

Figure 6-1 Transmission, Motor, Brake Assembly

SECTION 7

TRANSMISSION, DRIVE WHEEL, LOAD WHEEL

7-1. Drive Wheel.

1. Turn off the key switch (6, [Figure 12-22](#)) and disconnect the batteries.
2. Remove the compartment covers as described in paragraph [5-3](#).
3. Loosen but do not remove the five nuts (15, [Figure 7-1](#)).
4. Jack up the truck so the drive wheel is off the ground; then securely block the truck to prevent movement.
5. Remove the five nuts (15), five washers (14) and drive wheel (13) from the transmission (12).
6. Install new drive wheel in reverse order of removal.
7. Install the compartment covers as described in paragraph [5-3](#).
8. Reconnect the batteries and turn on the keyswitch (6, [Figure 12-22](#)).

7-2. Transmission.

1. Remove the drive wheel (13) as described in paragraph [7-1](#).
2. Remove the brake (1, [Figure 7-1](#)) as described in paragraph [6-1.1](#).
3. Remove the steering arm as described in paragraph [5-2.2](#).
4. Note routing of cables to ensure proper installation.
5. Tag the cables connected to the drive motor; then disconnect these cables from the drive motor.
6. Remove three screws (26, [Figure 12-1](#)) and three lock washers (27) to free brake plate (17) from motor (17, [Figure 7-1](#)).
7. Support the transmission (12, [Figure 7-1](#)) and remove the six screws (7), six lock washers (8) and six flat washers (9).
8. Slowly lower the transmission out the bottom of the frame.

9. Install new transmission by reversing the steps above.

7-3. Load Wheel.

7-3.1. Removal

1. Turn off the key switch (6, [Figure 12-22](#)) and disconnect the batteries.
2. Block the drive wheel to prevent the truck from rolling.
3. Jack up the truck to raise the load wheel off the floor. Securely block the truck in the raised position.
4. Remove three screws (1, [Figure 7-2](#)) and cover (2).
5. Remove two screws (3), two lock washers (4), two flat washers (5) and retainer (13).
6. Remove load wheel (6).
7. Remove bearings (7) from load wheel (6).

NOTE: Inspect the load wheel assembly. If the load wheel is worn within 1/8" of the metal sleeve, or is cracked or damaged, replace the entire load wheel and bearing assembly. Blue Giant recommends that both load wheel assemblies be replaced at the same time. This ensures level and safe operation of the lift truck.

7-3.2. Load Wheel Installation

1. Install bearings (7, [Figure 7-2](#)) in load wheel (6).
2. Position load wheel (6) on spindle.
3. Remove retainer (13) and secure with two screws (3), two lock washers (4) and two flat washers (5).
4. Install cover (2) and secure with three screws (1).
5. Remove blocking from under the truck and lower to the ground.
6. Reconnect the batteries and turn on the keyswitch (6, [Figure 12-22](#)).

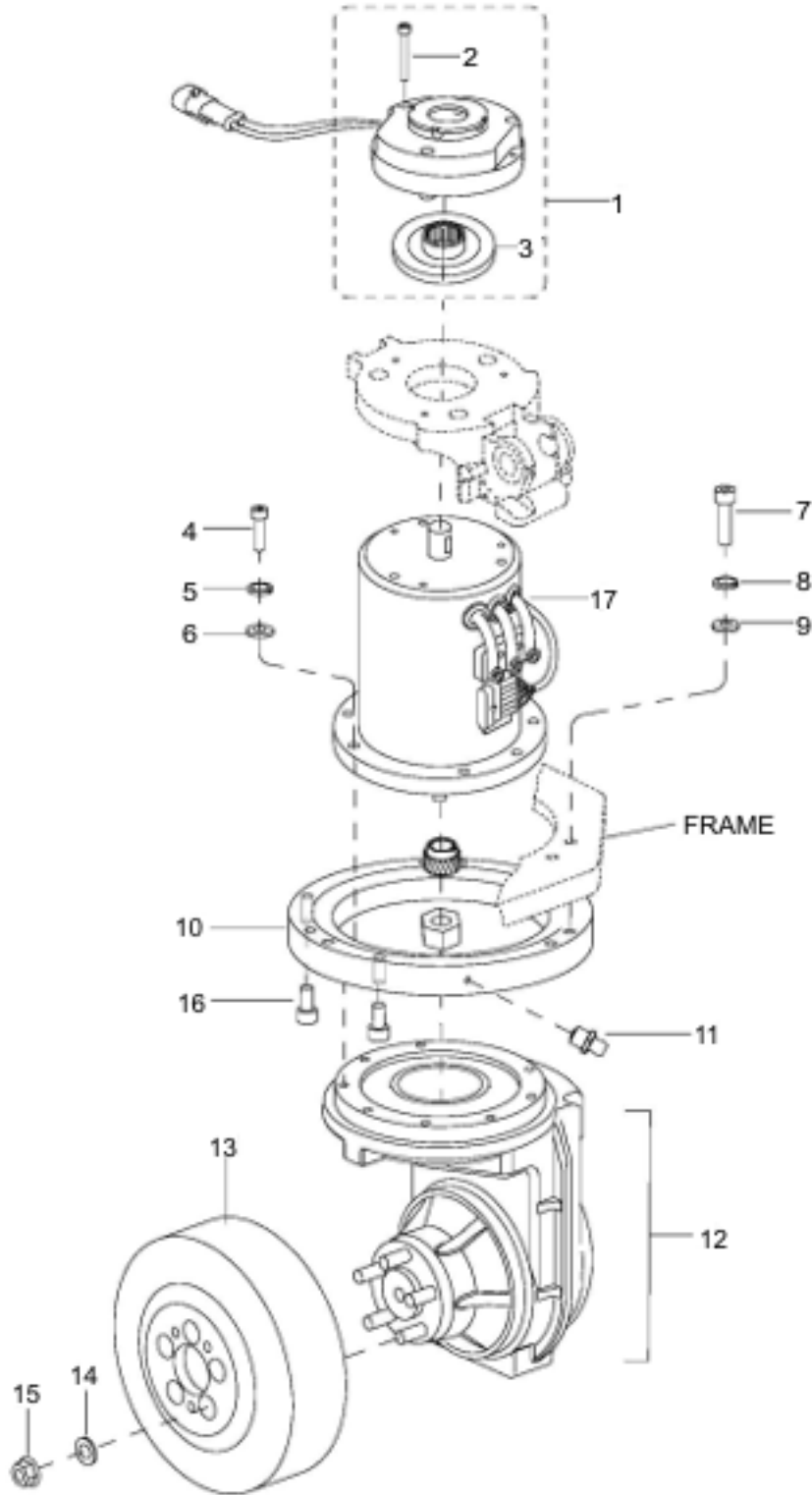

R6879

Figure 7-1 Transmission, Motor, Brake Assembly

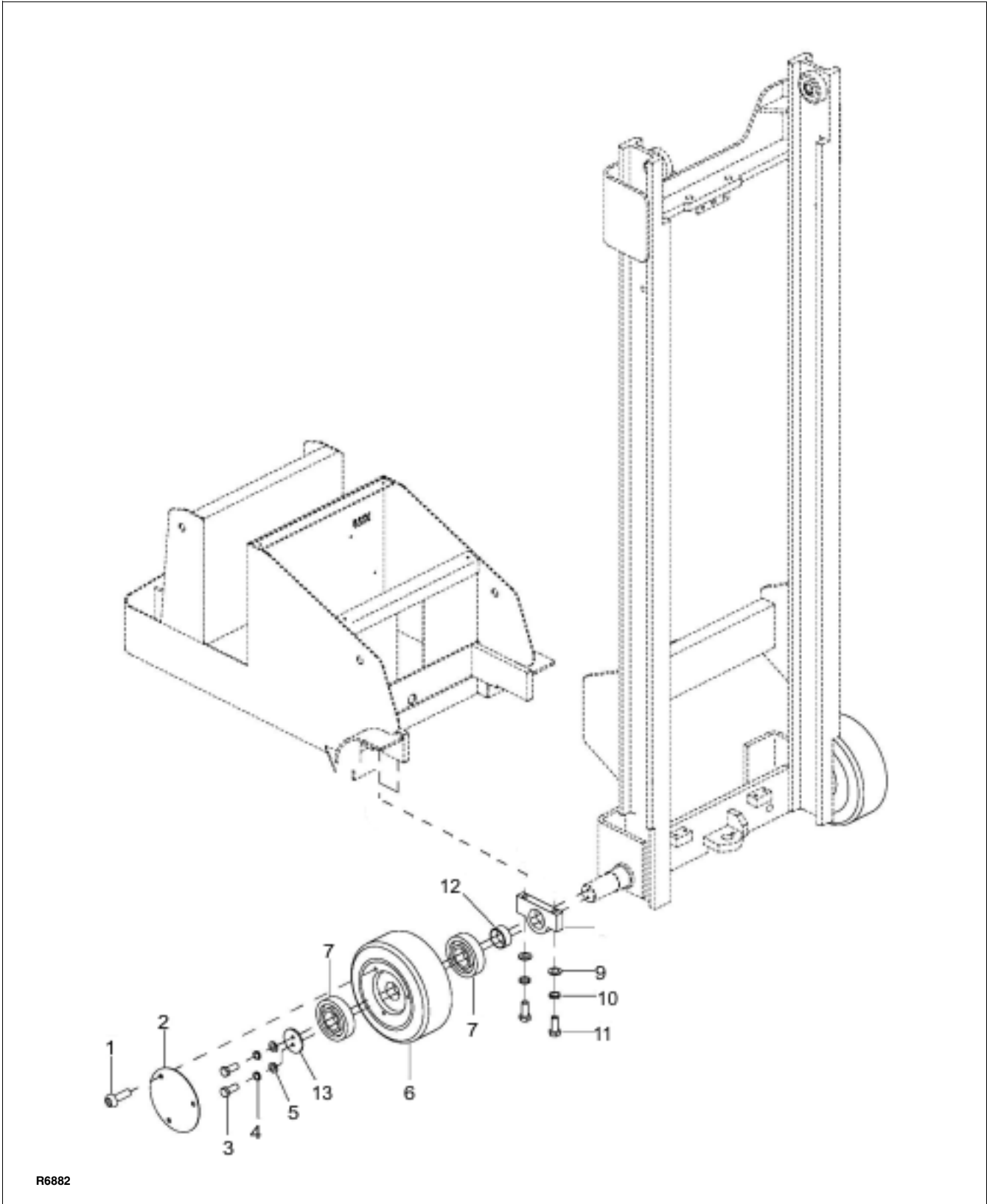

Figure 7-2 Load Wheels

NOTES

SECTION 8 ELEVATION SYSTEM SERVICING

8-1. GENERAL.

The elevation system includes the outer mast, inner mast, lift linkage, lift chains, lift cylinder and ram head.

8-2. LIFT CHAIN LENGTH ADJUSTMENT.

8-2.1. Telescopic

1. Fully lower the lift carriage.
2. Turn off the key switch (6, [Figure 12-22](#)) and disconnect the batteries.

WARNING: Before attempting any adjustment, make certain power is disconnected.

3. Loosen upper jam nuts (2, [Figure 8-1](#)), located above the mounts on outer mast (18, [Figure 8-2](#)), to allow for adjustment of middle jam nuts.
4. Break the lower jam nuts (2, [Figure 8-1](#)), located below the mounts on outer mast free from the middle jam nuts (2).
5. Take up slack in both lift chains with middle jam nut (2). Strive for equal tension on both chains.
6. Align adjusting bolts (1) so each clevis pin (4) is parallel to the mast.

CAUTION: At least 3 full threads must be present below lower nuts (2) after adjustment.

7. Tighten jam nuts securely while maintaining alignment of clevis pins (4).
8. Reconnect the batteries and turn on the keyswitch (6, [Figure 12-22](#)).
9. Test chain by operating carriage. If slack is still apparent, repeat above procedure.

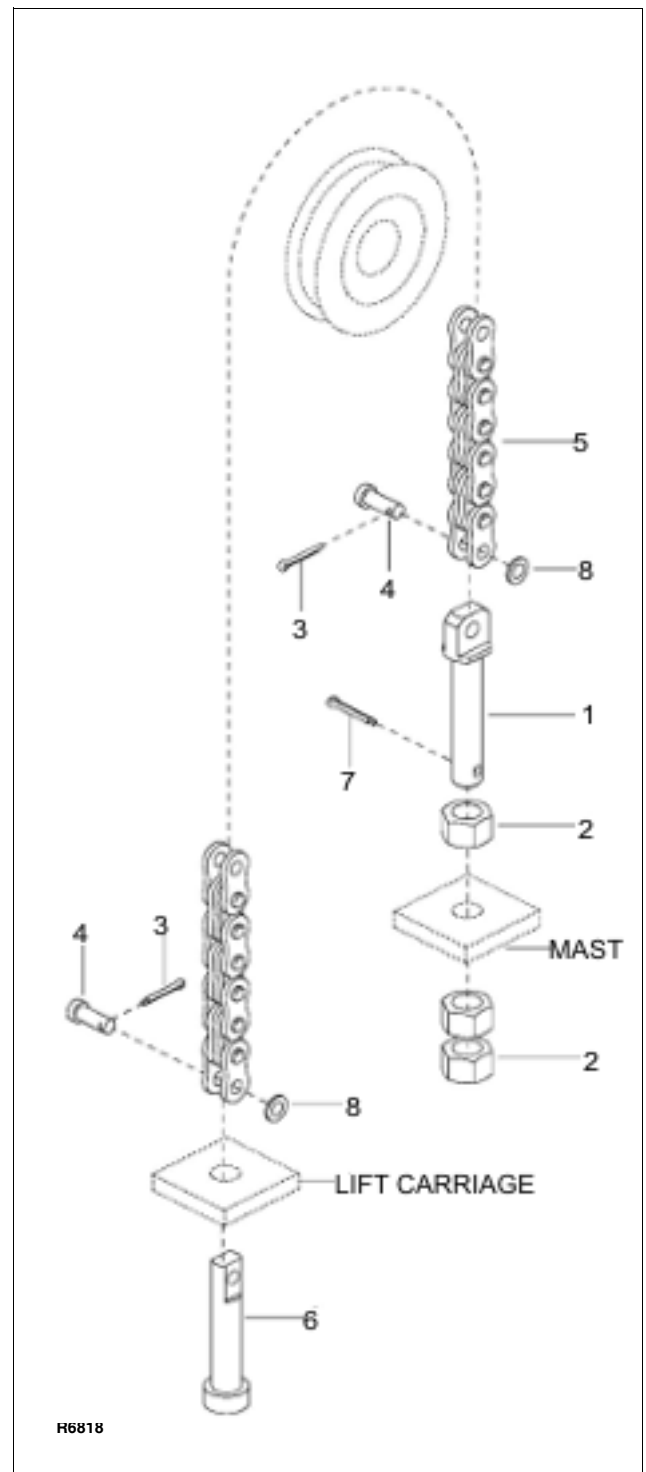
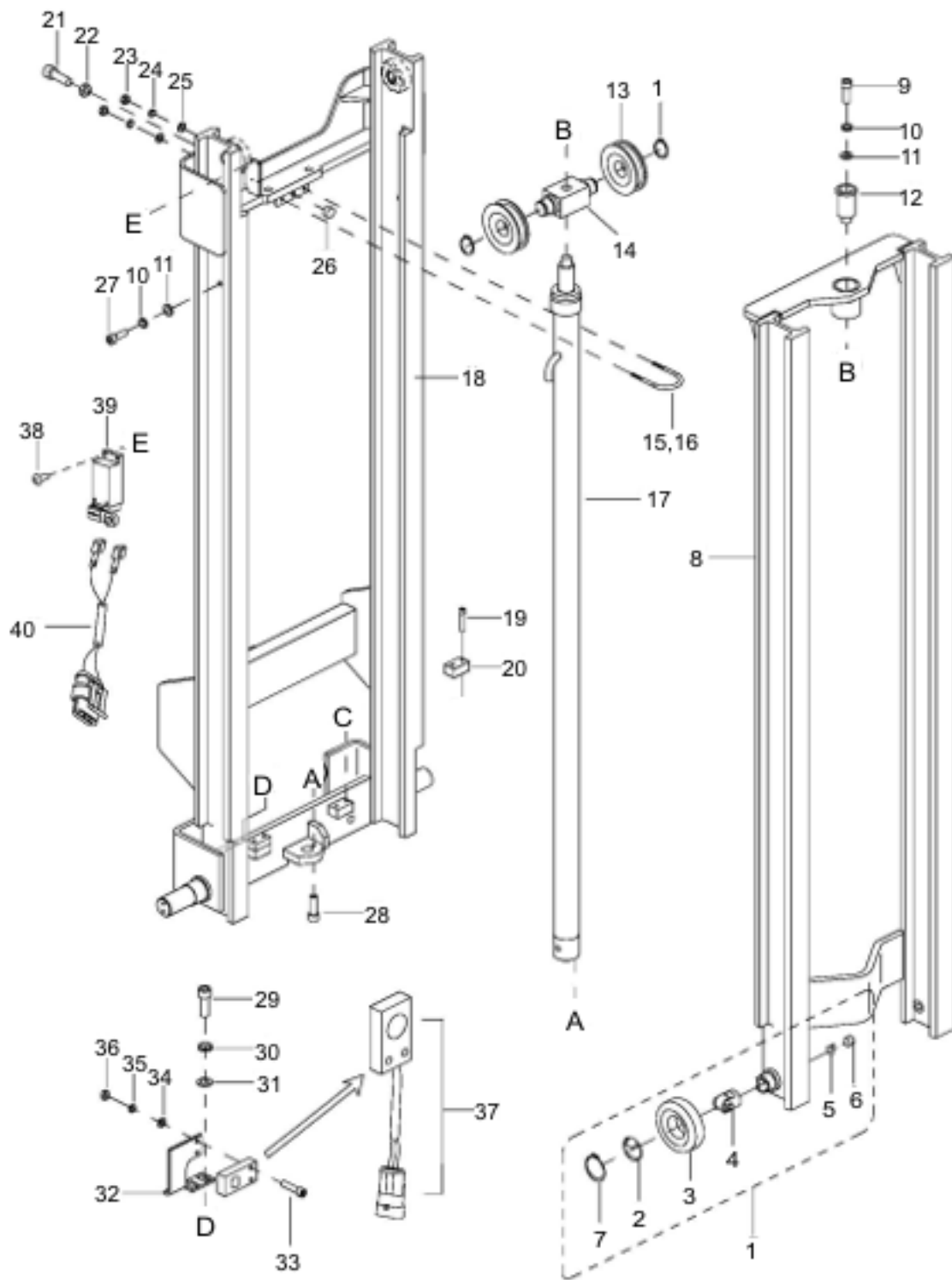

Figure 8-1 Chain Assembly



R6883

Figure 8-2 Elevation System (Telescopic)

8-2.2. TRIMAST Free Lift Chain

1. Fully lower the lift carriage.
2. Turn off the key switch (6, [Figure 12-22](#)) and disconnect the batteries.

WARNING: Before attempting any adjustment, make certain power is disconnected.

3. Loosen lower jam nuts (2, [Figure 8-1](#)), located above the mounts of cylinder (44, [Figure 8-3](#)), to allow for adjustment of middle jam nuts.
4. Break the lower jam nuts (2, [Figure 8-1](#)), located below the mounts of the cylinder, free from the middle jam nuts (2).
5. Take up slack in both lift chains with middle jam nut (2, [Figure 8-1](#)). Strive for equal tension on both chains.
6. Align anchors (1) so each clevis pin (4) is parallel to the mast.

CAUTION: At least 3 full threads must be present below lower nut (2, [Figure 8-1](#)) after adjustment.

7. Tighten jam nuts securely while maintaining alignment of clevis pins (4).
8. Reconnect the batteries and turn on the keyswitch (6, [Figure 12-22](#)).
9. Test chain by operating carriage. If slack is still apparent, repeat above procedure.

8-2.3. TRIMAST Secondary Lift Chain

1. Fully lower the lift carriage.
2. Turn off the key switch (6, [Figure 12-22](#)) and disconnect the batteries.

WARNING: Before attempting any adjustment, make certain power is disconnected.

3. Loosen jam nuts (2, [Figure 8-1](#)), the mount of outer mast (25, [Figure 8-3](#)), to allow for adjustment of middle jam nut.
4. Break the lower jam nuts (2, [Figure 8-1](#)), located below the mount of outer mast free from the middle jam nuts.
5. Take up slack in both lift chains with middle jam nut (2). Strive for equal tension on both chains.
6. Align anchors (1) so each clevis pin (4) is parallel to the outer mast (25, [Figure 8-3](#)).

CAUTION: At least 3 full threads must be present below lower nut (2, [Figure 8-1](#)) after adjustment.

7. Tighten jam nuts securely while maintaining alignment of clevis pins (4).
8. Reconnect the batteries and turn on the keyswitch (6, [Figure 12-22](#)).
9. Test chain by operating carriage. If slack is still apparent, repeat above procedure.

8-3. LIFT CHAIN WEAR INSPECTION.

Both lift chains should be replaced when either chain is worn enough to increase it's length by 3% or more. To make this determination proceed as follows.

Using a section of chain that sees the most frequent operation over the chain sheaves, isolate a vertical portion under tension from the weight of carriage and forks.

Measure the distance between pin centers on 20 vertical links. If the section measures 12.88" or more, the chain should be replaced.

New chain anchor pins should be installed when chains are replaced. Never replace a partial section of chain and never repair chain. Refer to paragraph 8-4. when installing new chain.

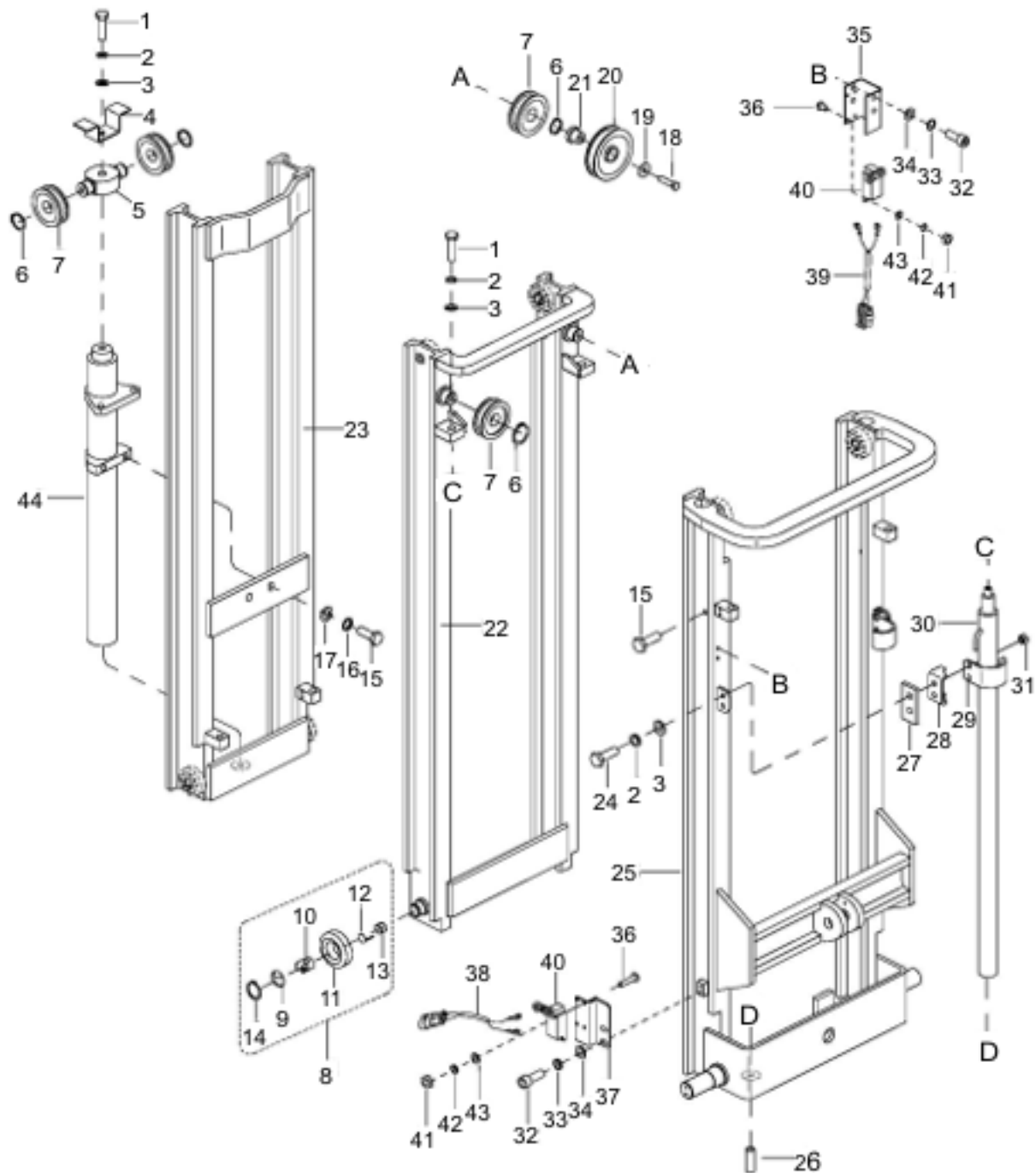

R6884

Figure 8-3 Mast (TRIMAST)

8-4. LIFT CHAIN REPLACEMENT.

8-4.1. Telescopic

1. With the lift truck wheels securely blocked, raise the forks approximately three feet from floor and position blocks or strong supports under inner mast (8, [Figure 8-2](#)).
2. Lower inner mast onto the support. Check that arrangement is secure before proceeding.
3. Turn off the key switch (6, [Figure 12-22](#)) and disconnect the batteries.

WARNING: Before attempting any replacement, make certain power is disconnected.

4. Remove cotter pin (3, [Figure 8-1](#)) and clevis pin (4) connecting chain (5) to chain anchor (6) at the lift carriage.
5. Remove cotter pin (3) and clevis pin (4) connecting chain (5) to chain anchor (1) at the outer mast (18, [Figure 8-2](#)).
6. Remove chain from sheave (13).
7. Position new chain on sheave (13).
8. Secure chain to chain anchor (1, [Figure 8-2](#)) at the outer mast with clevis pin (4) and cotter pin (3).
9. Connect the opposite end of chain to chain anchor (6) at the lift carriage with clevis pin (4) and cotter pin (3).
10. Adjust the chains according to paragraph [8-2](#).
11. Reconnect the batteries and turn on the keyswitch (6, [Figure 12-22](#)).

8-4.2. TRIMAST Free Lift Chain

1. With the lift truck wheels securely blocked, raise the forks approximately three feet from floor and position blocks or strong supports under the lift carriage.
2. Lower the lift carriage onto the support. Check that arrangement is secure before proceeding.
3. Turn off the key switch (6, [Figure 12-22](#)) and disconnect the batteries.

WARNING: Before attempting any replacement, make certain power is disconnected.

4. Remove cotter pin (3, [Figure 8-1](#)) and clevis pin (4) connecting chain (5) to chain anchor (6) at the lift carriage.

5. Remove cotter pin (3) and clevis pin (4) connecting chain (5) to chain anchor (1) at free lift cylinder (44, [Figure 8-3](#)).
6. Remove chain from sheave (7).
7. Position new chain on sheave (7).
8. Secure chain to chain anchor (1) at free lift cylinder (44) with clevis pin (4) and cotter pin (3).
9. Connect the opposite end of chain to chain anchor (6) at the lift carriage with clevis pin (4) and cotter pin (3).
10. Adjust the chains according to paragraph [8-2](#).
11. Reconnect the batteries and turn on the keyswitch (6, [Figure 12-22](#)).

8-4.3. TRIMAST Secondary Lift Chain

1. With the lift truck wheels securely blocked, raise the forks approximately five feet from floor and position blocks or strong supports under masts (22 and 25, [Figure 8-3](#)).
2. Lower the masts onto the support. Check that arrangement is secure before proceeding.
3. Turn off the key switch (6, [Figure 12-22](#)) and disconnect the batteries.

WARNING: Before attempting any replacement, make certain power is disconnected.

4. Remove cotter pin (3, [Figure 8-1](#)) and clevis pin (4) connecting chain (5) to chain anchor (6) at inner mast (23, [Figure 8-3](#)).
5. Remove cotter pin (3, [Figure 8-1](#)) and clevis pin (4) connecting chain (5) to chain anchor (1) at outer mast (25, [Figure 8-3](#)).
6. Remove chain from sheave (7).
7. Position new chain on sheave (7).
8. Secure chain to chain anchor (1) at outer mast (25, [Figure 8-3](#)) with clevis pin (4, [Figure 8-1](#)) and cotter pin (3).
9. Connect the opposite end of chain to chain anchor (6) at inner mast (23, [Figure 8-3](#)) with clevis pin (4, [Figure 8-1](#)) and cotter pin (3).
10. Adjust the chains according to paragraph [8-2](#).
11. Reconnect the batteries and turn on the keyswitch (6, [Figure 12-22](#)).

8-5. LIFT CYLINDERS.

NOTE: Removal and repair of lift cylinders are covered in [SECTION 9](#).

NOTES

SECTION 9 HYDRAULIC SYSTEM SERVICING

9-1. LINES AND FITTINGS

WARNING: When forks are raised, pressure exists in the hydraulic system lines and fittings. To ensure release of pressure, forks must be fully lowered and the batteries disconnected before performing any maintenance on the hydraulic system.

NOTE: Leaking hydraulic fittings may be remedied by simply tightening fittings. If this does not remedy the leak, the fittings or line must be replaced.

1. Lower forks fully.
2. Turn off the key switch (6, [Figure 12-22](#)) and disconnect the batteries.
3. Remove the front compartment covers as described in paragraph [5-3](#).

CAUTION: Hydraulic oil can damage parts. Wipe off any oil immediately. Provide a container under the line or fitting before disconnecting.

4. Refer to [Figure 9-1](#), [Figure 9-2](#) and [Figure 9-3](#) and remove leaking line or fitting and replace it with a new line or fitting.
5. Check level of hydraulic oil. If required, add hydraulic oil to bring to proper level. Use hydraulic oil listed in [Table 3-2](#).
6. Reconnect the batteries and turn on the keyswitch (6, [Figure 12-22](#)).
7. Operate the lift and lower buttons to refill the cylinder and lines with hydraulic oil.
8. Check level of hydraulic oil. If required, add hydraulic oil to bring to proper level. Use hydraulic oil listed in [Table 3-2](#).
9. Install the front compartment covers as described in paragraph [5-3](#).

9-2. HYDRAULIC PUMP, AND MOTOR ASSY

WARNING: When forks are raised, pressure exists in the hydraulic system lines and fittings. To ensure release of pressure, forks must be fully lowered and the batteries disconnected before performing any maintenance on the hydraulic system.

9-2.1. Removal

1. Lower forks fully.
2. Turn off the key switch (6, [Figure 12-22](#)) and disconnect the batteries.
3. Remove the front compartment covers as described in paragraph [5-3](#).
4. Tag and disconnect electrical leads from pump and motor (5, [Figure 9-1](#)).

NOTE: Place a container under the pump assembly to catch any hydraulic oil.

5. Tag and disconnect two hoses (13) from pump and motor (5).
6. **Telescopic Trucks:** Tag and disconnect hose (1, [Figure 9-2](#)) from pump and motor (5).

TRIMAST Trucks: Tag and disconnect hose (18, [Figure 9-3](#)) from pump and motor (5)

7. Remove two screws (1, [Figure 9-1](#)), two lock washers (2) four washers (4) and four washers (3).
8. Remove the pump and motor assembly (5) with reservoir (9).
9. Remove four bolts (8), four lock washers (7) and reservoir (9) from pump and motor assembly (5).

9-2.2. Disassembly and Reassembly

1. Remove the pump and motor assembly (5, [Figure 9-1](#)) as described in paragraph [9-2.1](#).
2. Refer to [Figure 12-14](#) for disassembly and reassembly of the pump and motor.
1. Install the pump and motor assembly (5, [Figure 9-1](#)) as described in paragraph [9-2.3](#).

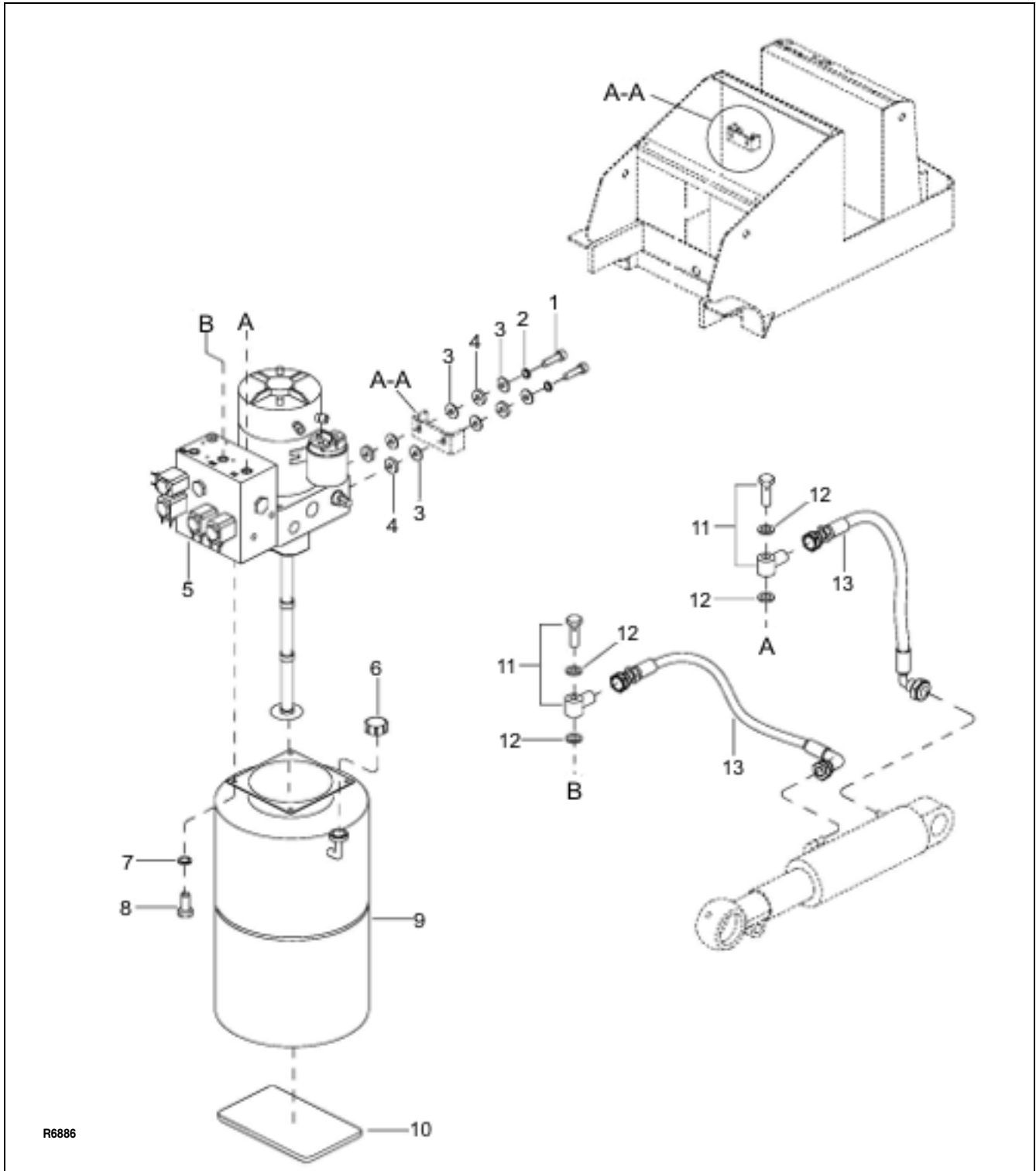

R6886

Figure 9-1 Hydraulic System

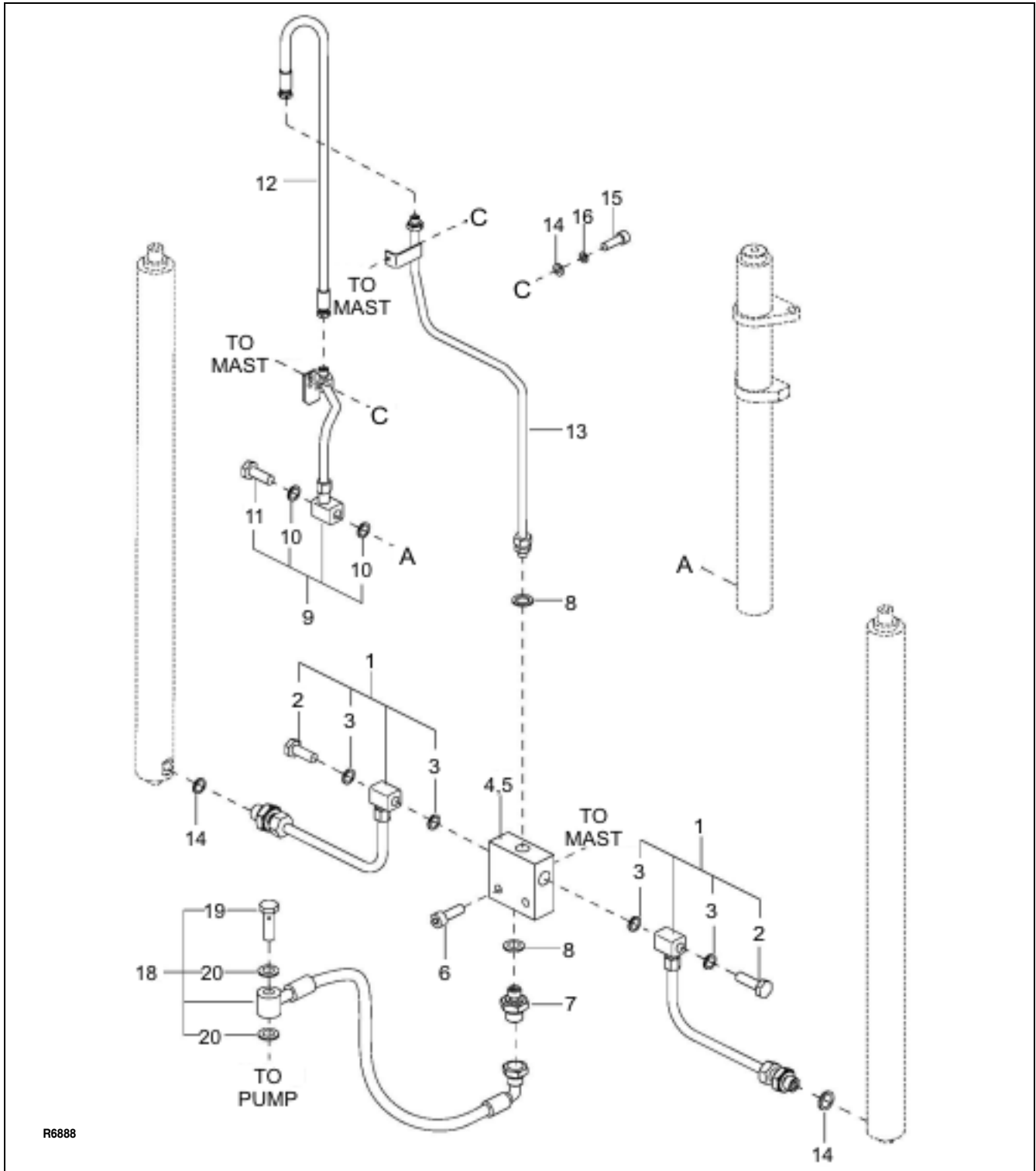

R6888

Figure 9-3 Hydraulic System (TRIMAST)

9-3. Lift Cylinder (Telescopic)

9-3.1. Removal

1. With the lift truck wheels securely blocked, raise the forks approximately three feet from floor and position blocks or strong supports under inner mast
2. Lower inner mast onto the support. Check that arrangement is secure before proceeding.
3. Turn off the key switch (6, [Figure 12-22](#)) and disconnect the batteries.

WARNING: Before attempting any replacement, make certain power is disconnected.

4. Remove screw (9, [Figure 9-4](#)), lock washer (10) and flat washer (11).
5. Remove screw (28).

CAUTION: Hydraulic oil can damage parts. Wipe off any oil immediately. Provide a container under the line or fitting before disconnecting.

6. Loosen hose (1, [Figure 9-2](#)) at the bottom of lift cylinder and manually push the cylinder rod down as far as possible. The chains will become slack and need not be removed.
7. Disconnect the hose from the bottom of lift cylinder.
8. Lift chains clear of sheaves (13, [Figure 9-4](#)) and lay them aside.

WARNING: Support lift cylinder before performing the following steps to prevent cylinder from falling.

9. Tilt lift cylinder (17) and ram head (14) forward from their position in the truck.
10. Lift ram head from the cylinder.
11. Raise lift cylinder assembly up and out of truck.

9-3.2. Repair

CAUTION: To prevent damage, use proper pipe clamp vise. The cylinder will be distorted if the vise is tightened too much.

1. Secure the lift cylinder in a vise, clamping lightly at the base of the cylinder.
2. Remove gland nut (7, [Figure 9-5](#)).
3. Remove wiper ring (8) and O-ring (9) from gland nut (7).
4. Pull out piston rod (1).

5. Remove bushing (4) and bearing (5)
6. Remove piston (2) and O-ring (3) from rod (1).
7. Remove packing (11) and backup ring (10) from piston (1).
8. Coat all parts with hydraulic oil ([Table 3-2](#)).
9. Install packing (11) and backup ring (10) on piston (1).
10. Install new O-ring (3) on rod (1).
11. Install piston (2) on rod (1).
12. Install bushing (4) and bearing (5)
13. Insert rod (1) in cylinder tube (6).
14. Install wiper ring (8) and O-ring (9) on gland nut (7).
15. Install gland nut (7) in cylinder tube (1).

9-3.3. Installation

1. Position the cylinder on outer mast (18, [Figure 9-4](#)).
2. With the cylinder tilted slightly forward, position ram head (14) on top of cylinder (17). Then tilt the cylinder back into position.
3. Lift up the lift chains and position them on sheaves (13).
4. Using a suitable lifting device, lift the inner mast and remove the supports.
5. Slowly lower the inner mast while lining up the lift cylinder with positioner (12).
6. Secure the top of the cylinder with screw (9), lock washer (10) and flat washer (11).
7. Secure the bottom of the cylinder with screw (28).
8. Reconnect the hose (1, [Figure 9-2](#)) to the bottom of lift cylinder.
9. Adjust the chains according to paragraph [8-2](#).
10. Fill the hydraulic reservoir. Use hydraulic oil listed in [Table 3-2](#).
11. Reconnect the batteries and turn on the keyswitch (6, [Figure 12-22](#)).
12. Operate the lift and lower buttons to refill the cylinder and lines with hydraulic oil.
13. Check level of hydraulic oil. If required, add hydraulic oil to bring to proper level. Use hydraulic oil listed in [Table 3-2](#).

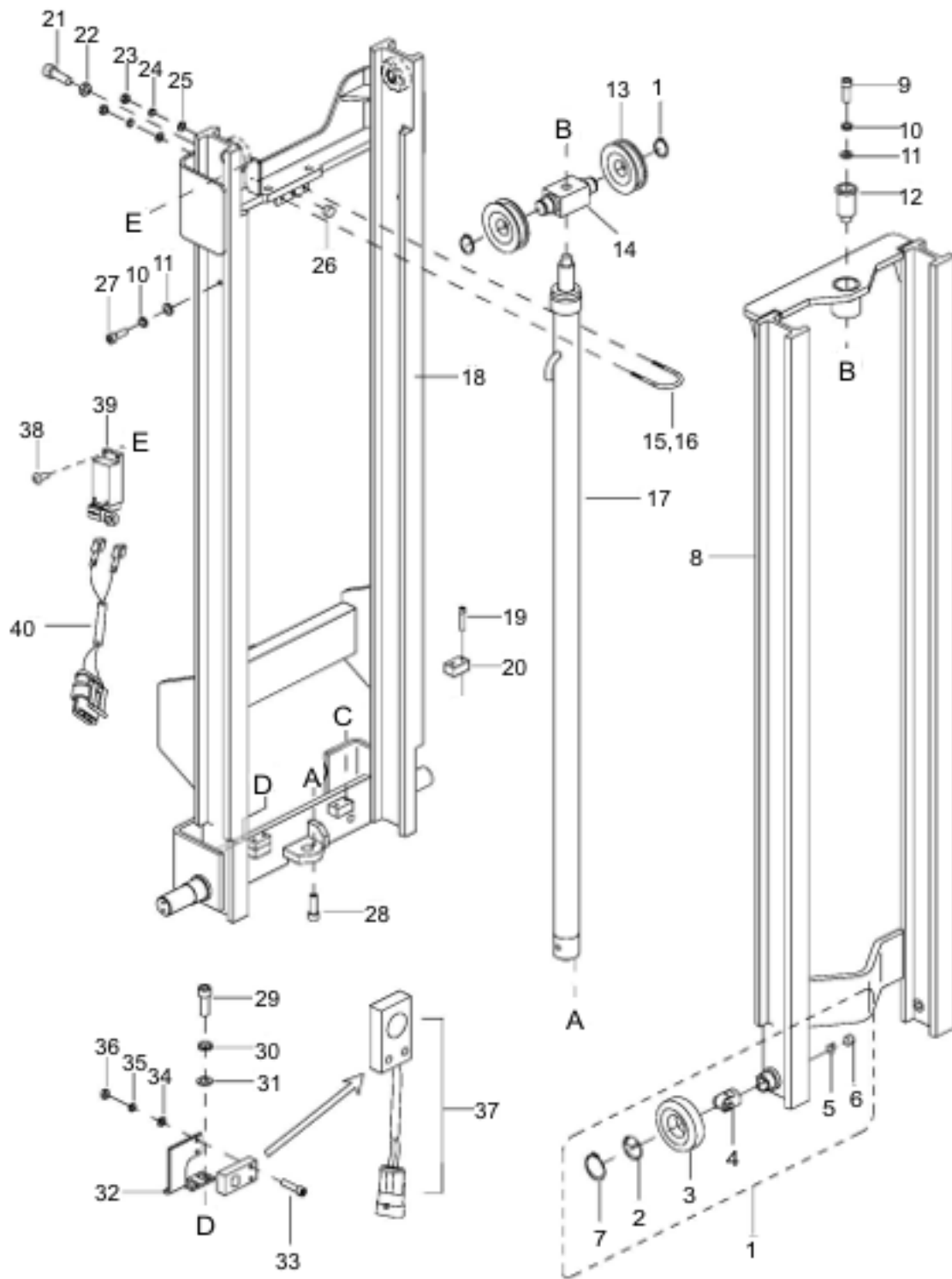

R6883

Figure 9-4 Elevation System (Telescopic)

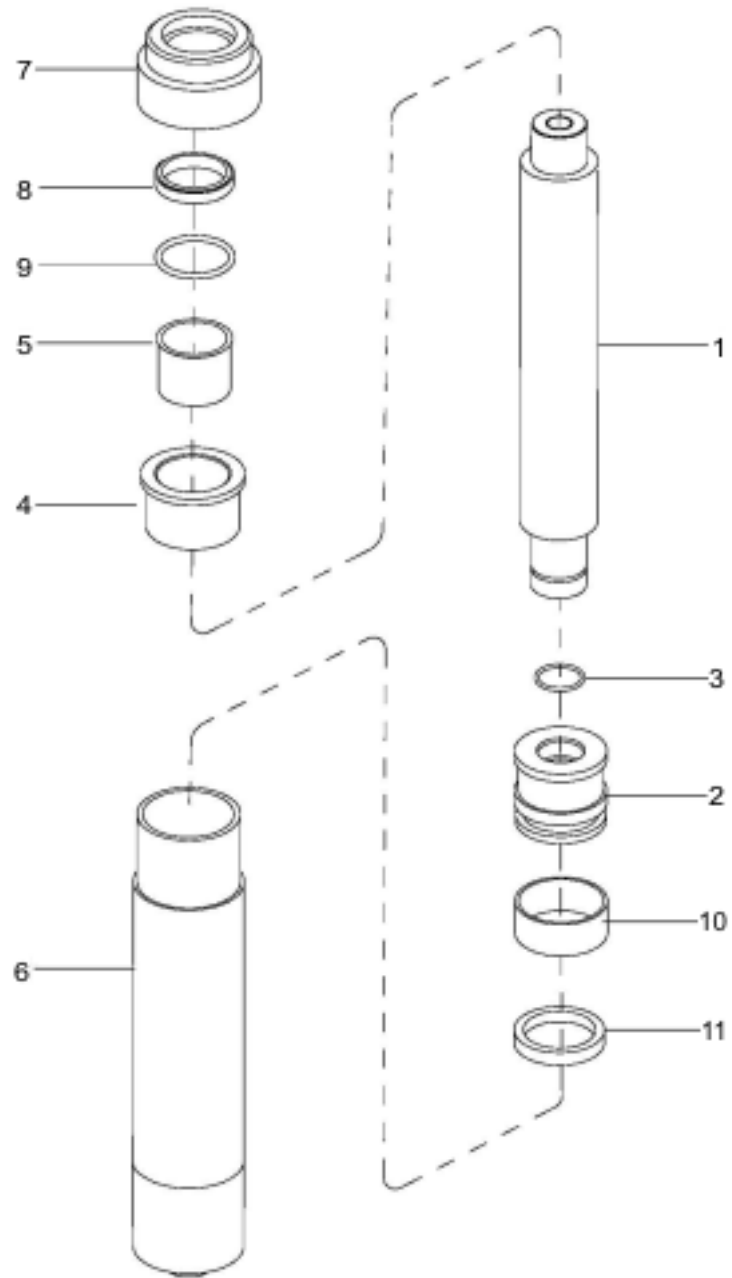

R6889

Figure 9-5 Lift Cylinder (Telescopic)

9-4. Lift Cylinder (TRIMAST Free Lift)

9-4.1. Removal

1. Fully lower the lift carriage.
2. Turn off the key switch (6, [Figure 12-22](#)) and disconnect the batteries.

WARNING: Before attempting any replacement, make certain power is disconnected.

3. Using another lift truck or suitable jack, raise lift carriage far enough to remove pressure on the free lift cylinder
4. Remove cotter pin and clevis pin connecting the lift chain to the anchor at cylinder (44, [Figure 9-6](#)).
5. Remove chains from sheaves (7).
6. Remove screw (1), lock washer (2), flat washer (3), bracket (4) and ram head (5) from cylinder (44)

CAUTION: Hydraulic oil can damage parts. Wipe off any oil immediately. Provide a container under the line or fitting before disconnecting.

7. Disconnect the tube (9, [Figure 9-3](#)) from the bottom of lift cylinder.
8. Support cylinder (44, [Figure 9-6](#)) and remove two screws (15), two lock washers (16) and two flat washers (17).
9. Raise lift cylinder assembly up and out of truck.

9-4.2. Repair

CAUTION: To prevent damage, use proper pipe clamp vise. The cylinder will be distorted if the vise is tightened too much.

1. Secure the lift cylinder in a vise, clamping lightly at the base of the cylinder.
2. Remove gland nut (4, [Figure 9-7](#)).

3. Remove wiper (1), collar (2), packing (3) and O-ring (5) from gland nut (4).
4. Pull out piston rod (6).
5. Remove ring (7) from piston rod (6).
6. Coat all parts with hydraulic oil ([Table 3-2](#)).
7. Install ring (7) on piston rod (6).
8. Insert rod (6) in cylinder tube (8).
9. Install O-ring (5), wiper (1), collar (2), and packing (3) on gland nut (4).
10. Install gland nut (4) in cylinder tube (8).

9-4.3. Installation

1. Position cylinder (44, [Figure 9-6](#)) on inner mast (23) and secure with two screws (15), two lock washers (16) and two flat washers (17).
2. Reconnect the tube (9, [Figure 9-3](#)) to the bottom of the cylinder.
3. Position bracket (4, [Figure 9-6](#)) and ram head (5) on cylinder (44) and secure with screw (1), lock washer (2), and washer (3).
4. Position lift chains over sheave, (7) and secure lift chain to the anchor at cylinder (44) with clevis pin and cotter pin.
5. Adjust the chains according to paragraph [8-2](#).
6. Fill the hydraulic reservoir. Use hydraulic oil listed in [Table 3-2](#).
7. Reconnect the batteries and turn on the keyswitch (6, [Figure 12-22](#)).
8. Operate the lift and lower buttons to refill the cylinder and lines with hydraulic oil.
9. Check level of hydraulic oil. If required, add hydraulic oil to bring to proper level. Use hydraulic oil listed in [Table 3-2](#).

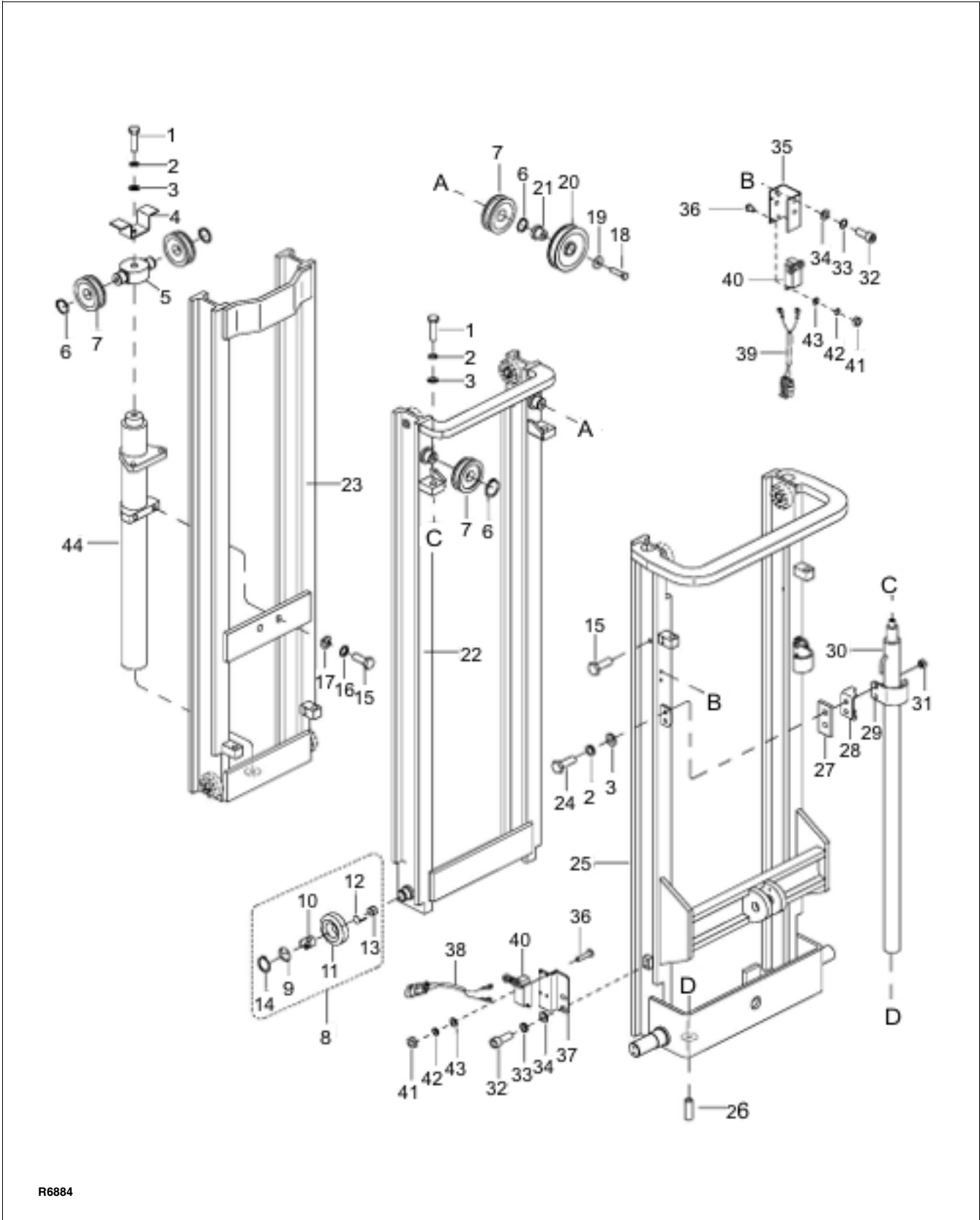

R6884

Figure 9-6 Elevation System (TRIMAST)

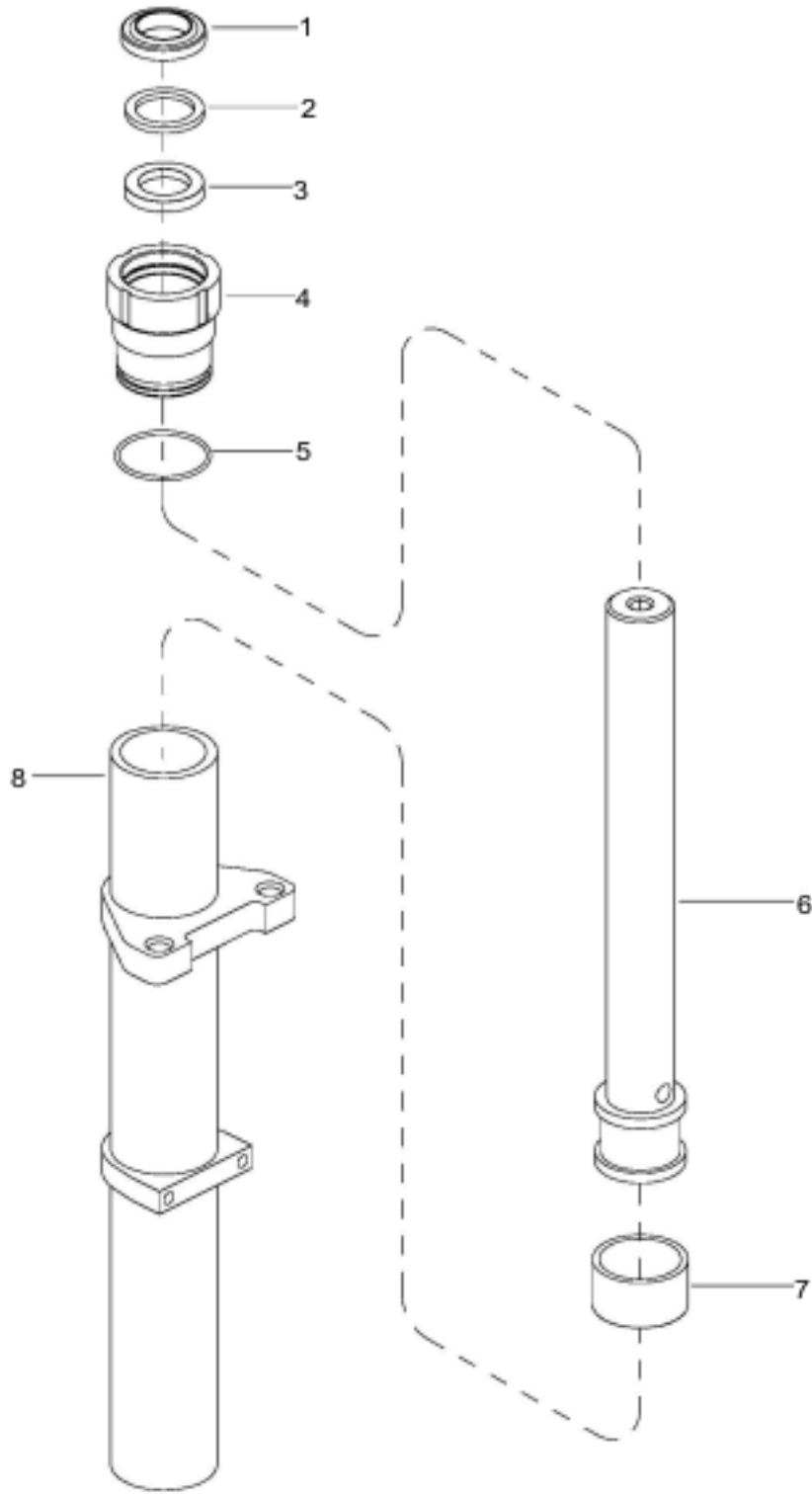

R6890

Figure 9-7 Free Lift Cylinder (TRIMAST)

9-5. Lift Cylinder (TRIMAST Secondary)

9-5.1. Removal

1. Fully lower the lift carriage.
2. Turn off the key switch (6, [Figure 12-22](#)) and disconnect the batteries.

WARNING: Before attempting any replacement, make certain power is disconnected.

3. Remove screw (1, [Figure 9-6](#)), lock washer (2) and flat washer (3) securing the top of cylinder (30) to mast (22).
4. Using another lift truck or suitable jack, raise middle mast (22) far enough to remove pressure on the secondary lift cylinder (30).

CAUTION: Hydraulic oil can damage parts. Wipe off any oil immediately. Provide a container under the line or fitting before disconnecting.

5. Disconnect the tube (1, [Figure 9-3](#)) from the bottom of lift cylinder.
6. Support cylinder (30) and remove two bolts (24), two lock washers (2), two flat washers (2), shims (27), bracket (28), clip (20) and nut (31).
7. Raise lift cylinder assembly up and out of truck.

9-5.2. Repair

CAUTION: To prevent damage, use proper pipe clamp vise. The cylinder will be distorted if the vise is tightened too much.

1. Secure the lift cylinder in a vise, clamping lightly at the base of the cylinder.
2. Remove gland nut (3, [Figure 9-8](#)).
3. Remove wiper (1), packing (2) and O-rings (4 and 11) from gland nut (3).

4. Pull out piston rod (5).
5. Remove backup ring (8), retaining ring (7) and bushing (6) from piston rod (5).
6. Coat all parts with hydraulic oil ([Table 3-2](#)).
7. Install backup ring (8), retaining ring (7) and bushing (6) on piston rod (5).
8. Insert rod (5) in cylinder tube (9).
9. Install wiper (1), packing (2) and O-rings (4 and 11) on gland nut (3).
10. Install gland nut (3) in cylinder tube (9).

9-5.3. Installation

1. Using another lift truck or suitable jack, raise middle mast (22, [Figure 9-6](#)) far enough to allow installation of the secondary lift cylinder (30).
2. Slowly lower mast (22) while aligning cylinder (30) with the tap on mast (22).
3. Secure the top of cylinder (30) with flat washer (3), lock washer (2) and screw (1).
4. Install clip (29), bracket (28), shims (27), two flat washers (3), two lock washers (2), two bolts (24) and two nuts (31).
5. Reconnect the tube (1, [Figure 9-3](#)) to the bottom of the lift cylinder.
6. Fill the hydraulic reservoir. Use hydraulic oil listed in [Table 3-2](#).
7. Reconnect the batteries and turn on the keyswitch (6, [Figure 12-22](#)).
8. Operate the lift and lower buttons to refill the cylinders and lines with hydraulic oil.
9. Check level of hydraulic oil. If required, add hydraulic oil to bring to proper level. Use hydraulic oil listed in [Table 3-2](#).
10. Install the compartment covers as described in paragraph [5-3](#).

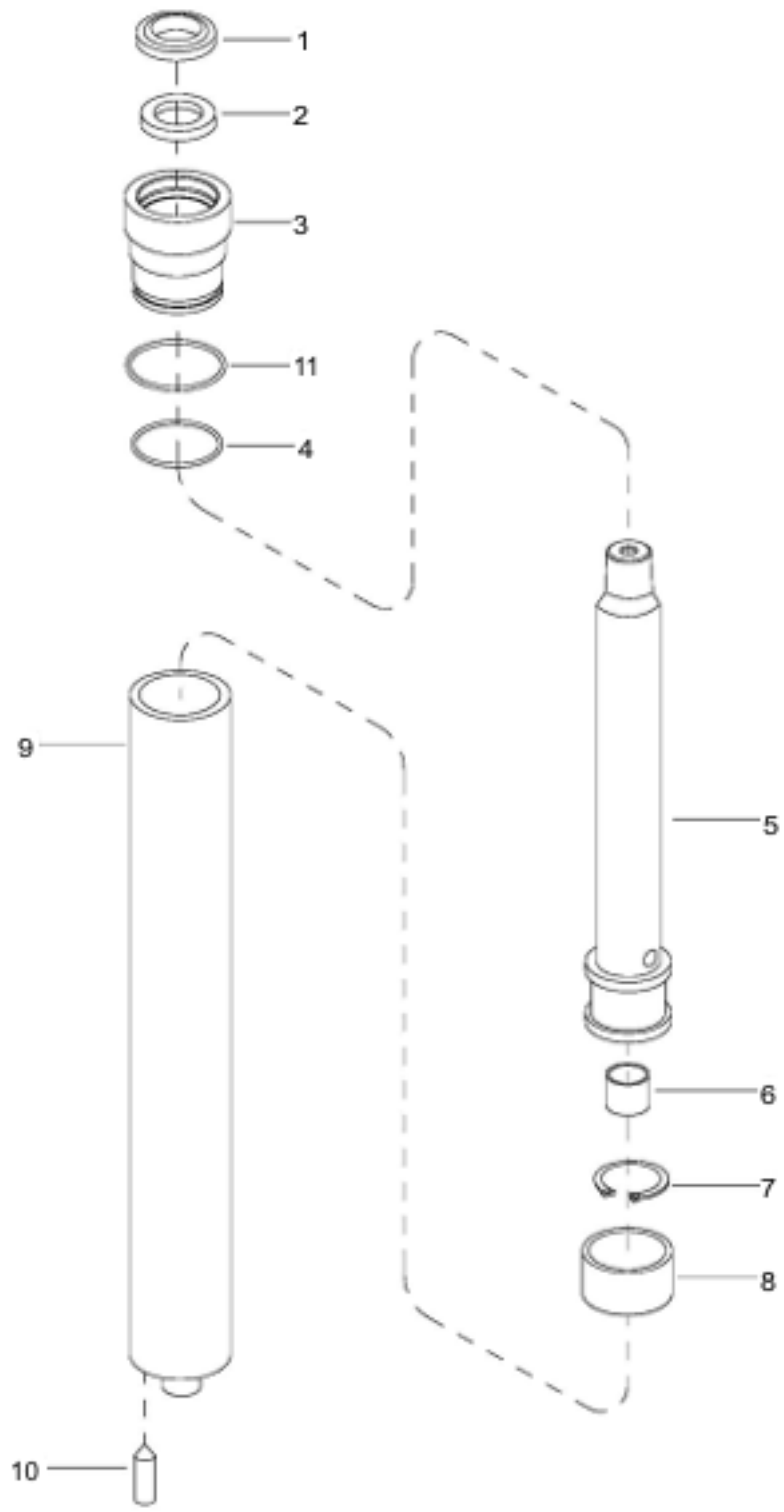

R6891

Figure 9-8 Secondary Lift Cylinder (TRIMAST)

9-5.4. Tilt Cylinders

9-5.4.1. Removal

WARNING: Mast must be supported by a hoist before removing the tilt cylinders.

1. Secure mast with a hoist.
2. Turn off the key switch (6, [Figure 12-22](#)) and disconnect the batteries.

WARNING: Before attempting any replacement, make certain power is disconnected.

CAUTION: Hydraulic oil can damage parts. Wipe off any oil immediately. Provide a container under the line or fitting before disconnecting.

3. Remove the front compartment covers as described in paragraph 5-3.
4. Disconnect hoses (13, [Figure 9-1](#)) from the tilt cylinder.
5. Support the tilt cylinder and remove bolts (1, [Figure 9-9](#)), lock washers (2), flat washers (2) and pins (4) and shaft (19) from the cylinder.
6. Carefully raise tilt cylinder from the truck.

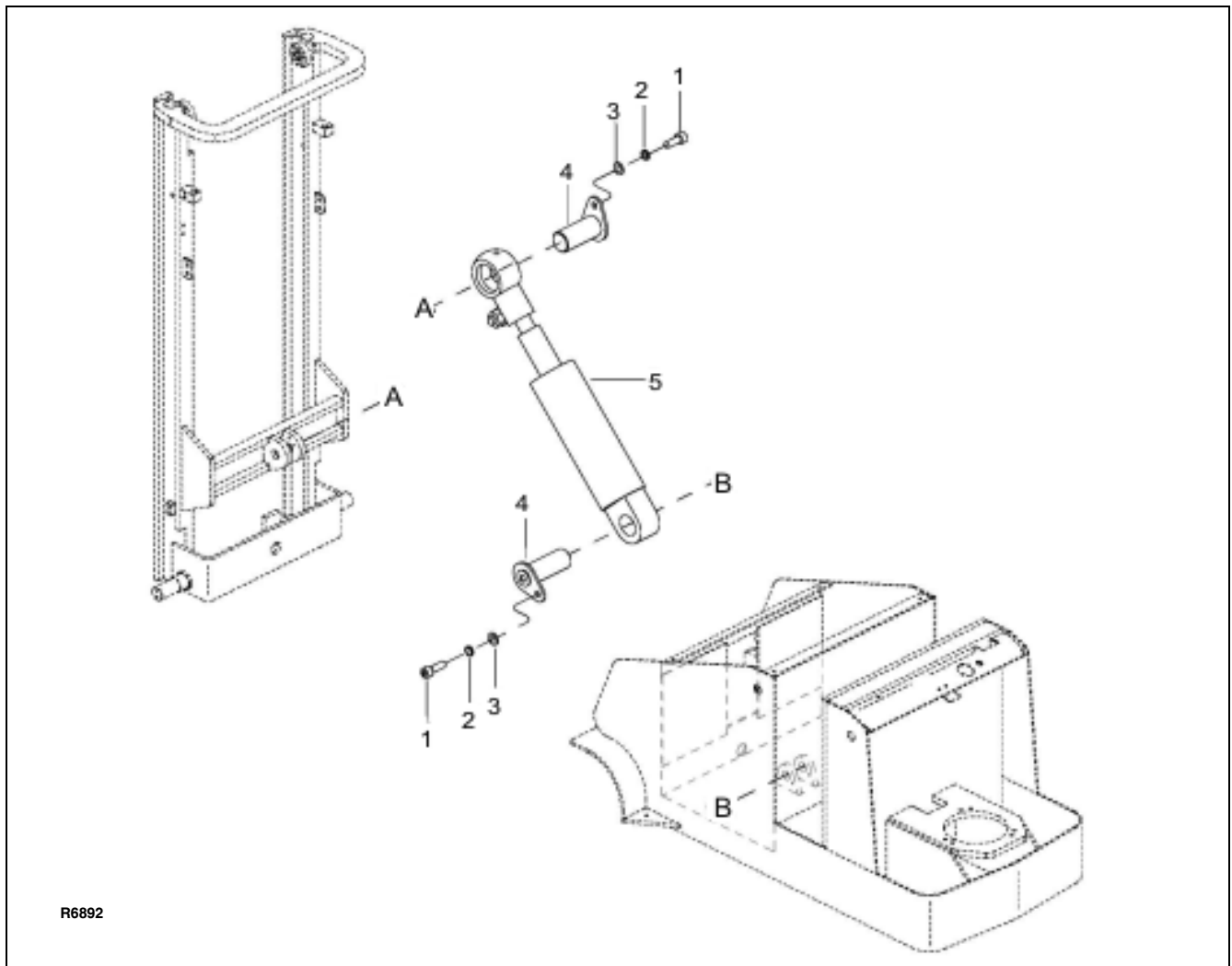

Figure 9-9 Tilt Cylinder Mounting

9-5.4.2.Repair

CAUTION: To prevent damage, use proper pipe clamp vise. The cylinder will be distorted if the vise is tightened too much.

1. Remove nut (6, [Figure 9-10](#)), lock washer (6) and bolt (4).
2. Remove clevis (1) from piston rod (14).
3. In necessary, remove retaining rings (3) and bearing (2) from clevis (1).
4. Remove gland nut (11) from tube (17).
5. Remove dust seal (7), O-ring (8), snap ring (9), seal (10), O-ring (13) and bearing (12) from gland nut (11).
6. Pull piston rod (14) out of tube (17).
7. Remove seals (16) and wear ring (15) from piston rod (15).
8. If necessary, remove bearing (18) from tube (17).
9. Coat all parts with hydraulic oil ([Table 3-2](#)).
10. Install bearing (18) in tube (17).
11. Install seals (16) and wear ring (15) on piston rod (15).
12. Install piston rod (14) in cylinder body (17).
13. Install dust seal (7), O-ring (8), snap ring (9), seal (10), O-ring (13) and bearing (12) in gland nut (11).

14. Install gland nut (11) in tube (17).
15. Install retaining rings (3) and bearing (2) in clevis (1).
16. Install clevis (1) on piston rod (14) and secure with bolt (4), lock washer (6) and nut (6).

9-5.4.3.Installation

1. Position the cylinder between the outer mast and the truck frame.
2. Secure the cylinder with shafts (19, [Figure 9-9](#)), bolts (1), lock washers (2), and flat washers (2).
3. Reconnect hoses (13, [Figure 9-1](#)) to the tilt cylinders.
4. Fill the hydraulic reservoir. Use hydraulic oil listed in [Table 3-2](#).
5. Reconnect the batteries and turn on the keyswitch (6, [Figure 12-22](#)).
6. Operate the tilt buttons to refill the cylinder and lines with hydraulic oil.
7. Check level of hydraulic oil. If required, add hydraulic oil to bring to proper level. Use hydraulic oil listed in [Table 3-2](#).
8. Install the front compartment covers as described in paragraph [5-3](#).

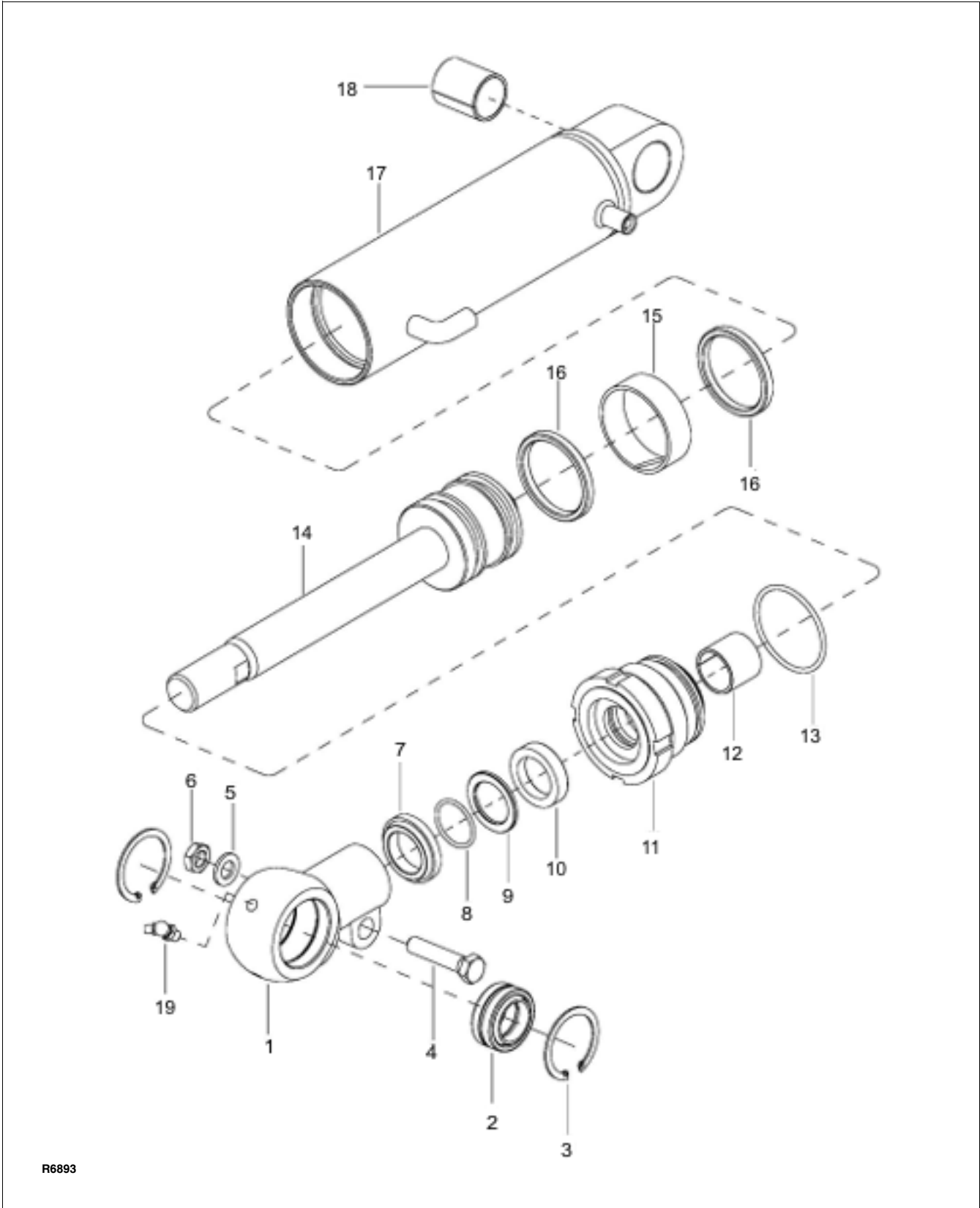

Figure 9-10 Tilt Cylinder

R6893

NOTES

SECTION 10 ELECTRICAL COMPONENTS

10-1.ELECTRICAL CONTROL PANEL

10-1.1.Maintenance

NOTE: Erratic operation of the truck may be caused by defective controller components. Before removing the electrical panel, perform troubleshooting procedures per [SECTION 4](#), to determine corrective action to be taken.

There are no user-serviceable parts inside the controller. No attempt should be made to open the controller. Opening the controller may damage it and will void the warranty.

The controller is programmed at the factory specifically for the truck model on which it is equipped. It is important to replace the controller with the correct pre-programmed unit to assure proper performance settings intended for that particular truck. See [Figure 12-23](#) for the preprogrammed controller number.

It is recommended that the controller exterior be cleaned periodically, and if a Zapi Handset is available, this periodic cleaning provides a good opportunity to check the controller's diagnostic history file. It is also recommended that the controller's fault detection circuitry be checked whenever the vehicle is serviced.

10-1.2. Cleaning

1. Turn off the key switch (6, [Figure 12-22](#)) and disconnect the batteries.
2. Remove the compartment covers as described in paragraph [5-3](#).
3. Remove any dirt or corrosion from the bus bar area. The controller should be wiped clean with a moist rag. Allow it to dry before reconnecting the battery.
4. Make sure the connections to the buss bars are tight. Use two well insulated wrenches for this task in order to avoid steering the buss bars.

10-1.3. Panel Removal.

1. Turn off the key switch (6, [Figure 12-22](#)) and disconnect the batteries.

2. Remove the compartment covers as described in paragraph [5-3](#).
3. Tag and disconnect all electrical cables which connect to the control panel (5, [Figure 10-1](#)).
4. Remove two screws (1), two lock washers (2), two flat washers (3), horn (4) and control panel (5).

10-1.4. Panel Disassembly.

Refer to [Figure 10-2](#) for location and identity of the major replacement components mounted on the panel and remove defective parts.

NOTE: Contactor (10) is not repairable and must be replaced if defective.

10-1.5. Panel Installation.

1. Install the control panel (5, [Figure 10-1](#)) and horn (4). Secure with two screws (1), two lock washers (2) and two flat washers (3).
2. Connect all electrical cables to the control panel as noted during removal.
3. Install the compartment covers as described in paragraph [5-3](#).
4. Reconnect the batteries and turn on the keyswitch (6, [Figure 12-22](#)).

10-2.HORN REPLACEMENT

1. Turn off the key switch (6, [Figure 12-22](#)) and disconnect the batteries.
2. Remove the compartment covers as described in paragraph [5-3](#).
3. Tag and disconnect all electrical connections from horn (4, [Figure 10-1](#)).
4. Remove screws (1), lock washers (2), flat washers (3) and horn (4).
5. Install horn and secure with screws (1), lock washers (2), flat washers (3).
6. Install the compartment covers as described in paragraph [5-3](#).
7. Reconnect the batteries and turn on the keyswitch (6, [Figure 12-22](#)).

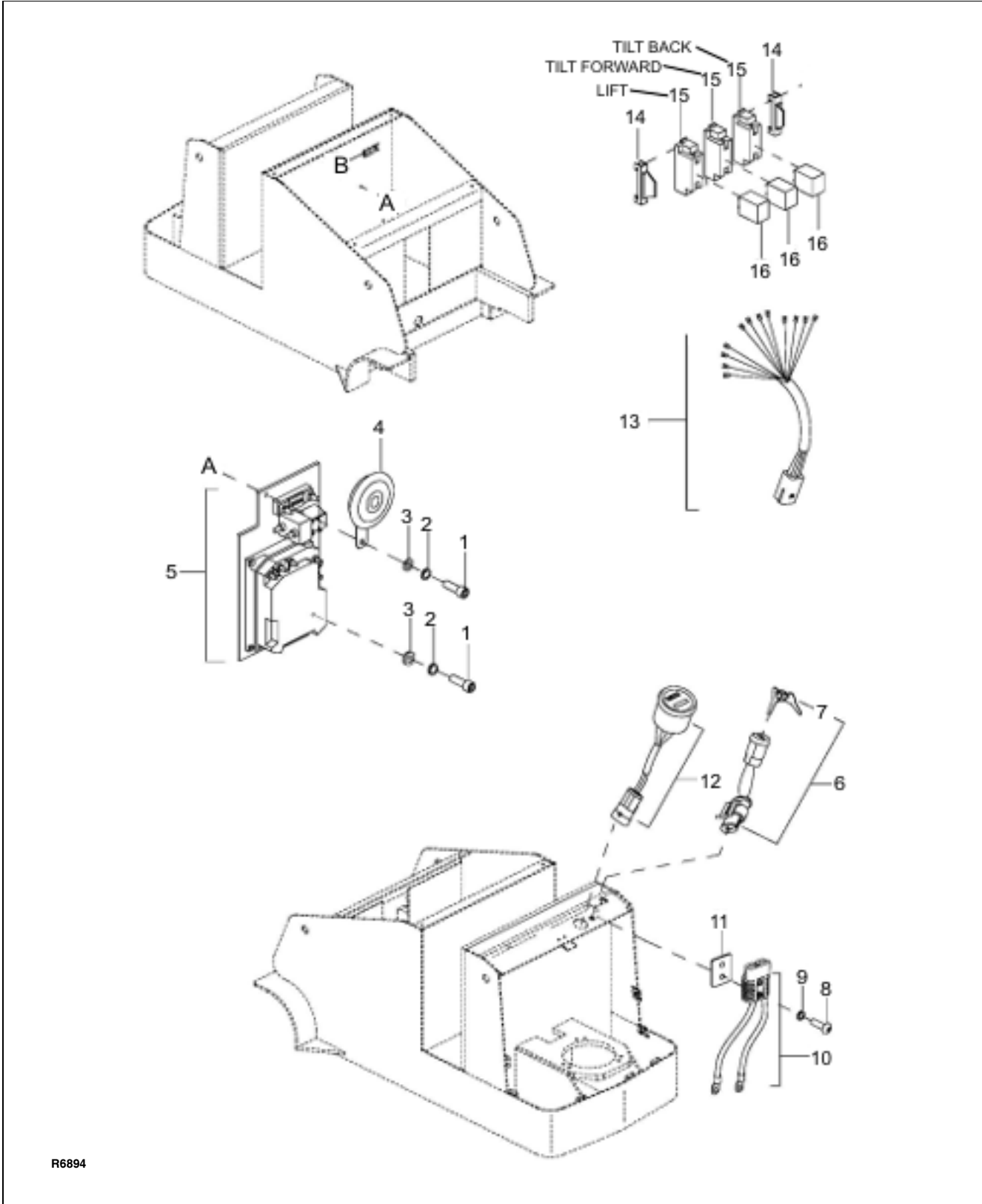

R6894

Figure 10-1 Electrical System

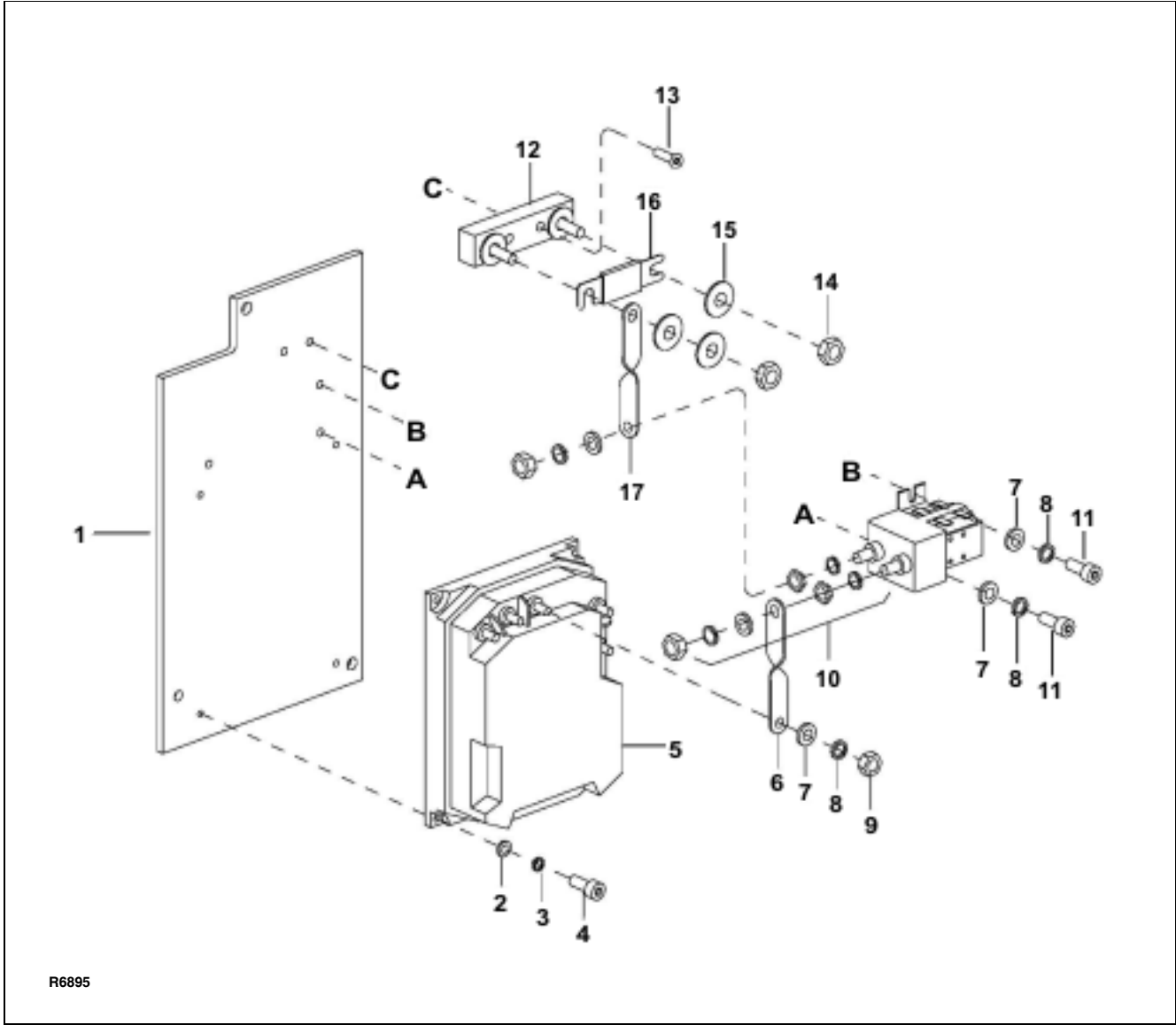

R6895

Figure 10-2 Electrical Panel

10-3.PUMP MOTOR.

Refer to paragraph 9-2.

10-4.DRIVE MOTOR.

The drive motor exposed surfaces should be cleaned at least once a month to assure proper cooling of motor. Use an air hose to blow dust off of motor surfaces.

10-4.1.Motor Removal

1. Remove the drive wheel (13) as described in paragraph 7-1.
2. Remove the brake (1, [Figure 10-3](#)) as described in paragraph 6-1.1.
3. Remove the steering arm as described in paragraph 5-2.2.
4. Note routing of cables to ensure proper installation.
5. Tag the cables connected to the drive motor; then disconnect these cables from the drive motor.
6. Remove three screws (26, [Figure 12-1](#)) and three lock washers (27) to free brake plate (17) from motor (17, [Figure 10-3](#))
7. Remove eight screws (4), eight lock washers (5) and eight flat washers (6).
8. Remove drive motor (17) from transmission (12).
9. Remove the nut and gear from the shaft of motor (17).

10-4.2.Motor Installation

1. Install the gear and nut on the shaft of motor (17).
2. Install drive motor onto transmission. Make sure the gears align.

3. Reinstall eight screws (4), eight lock washers (5) and eight flat washers (6) to secure the motor to the transmission.
4. Install brake plate (17, [Figure 12-1](#)) on the motor and secure with three screws (26) and three lock washers (27)
5. Position cables as noted in removal and reconnect cables to the drive motor.
6. Reinstall the brake as described in paragraph 6-1.1.
7. Reinstall the steering arm as described in paragraph 5-2.3.
8. Install the rear compartment covers as described in paragraph 5-3.

10-5.DEADMAN SWITCH

10-5.1.Replacement

1. Turn off the key switch (6, [Figure 12-22](#)) and disconnect the batteries.
2. Remove two screws (4, [Figure 12-6](#)) and middle cover (5).
3. Disconnect the harness from deadman switch (29, [Figure 12-6](#)).
4. Remove two screws (21) and deadman switch (29).
5. Install new switch (29) and secure with two screws (21).
6. Reconnect the deadman switch wiring.
7. Check for proper operation of switch (29).
8. Install middle cover (5) and secure with two screws (4, [Figure 12-6](#)).
9. Reconnect the batteries and turn on the keyswitch (6, [Figure 12-22](#)).

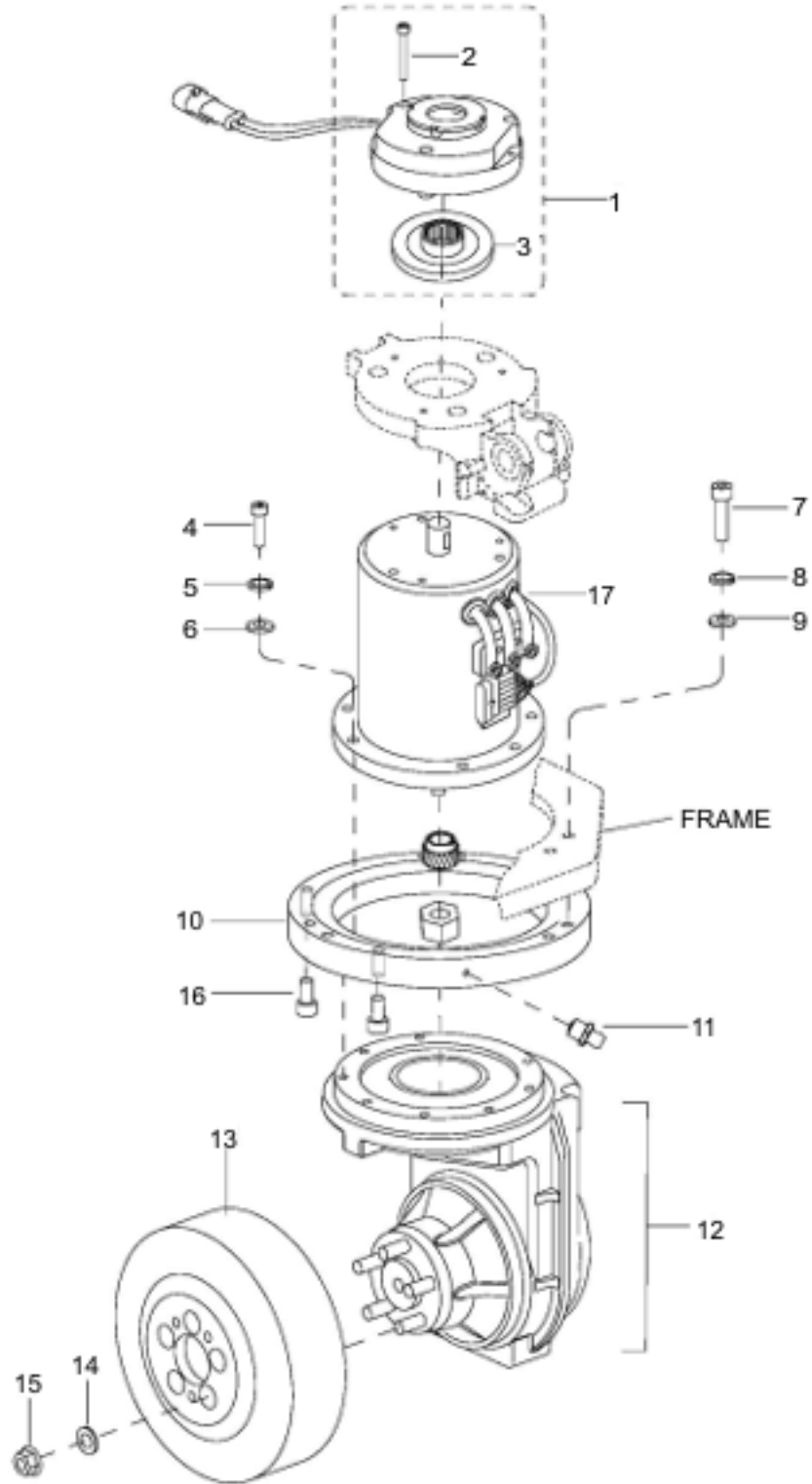

R6879

Figure 10-3 Transmission, Motor, Brake Assembly

NOTES

**SECTION 11
OPTIONAL EQUIPMENT**

NOTES

SECTION 12
ILLUSTRATED PARTS BREAKDOWN

Following is an illustrated parts breakdown of assemblies and parts associated with the BGL-22 Lift Truck.

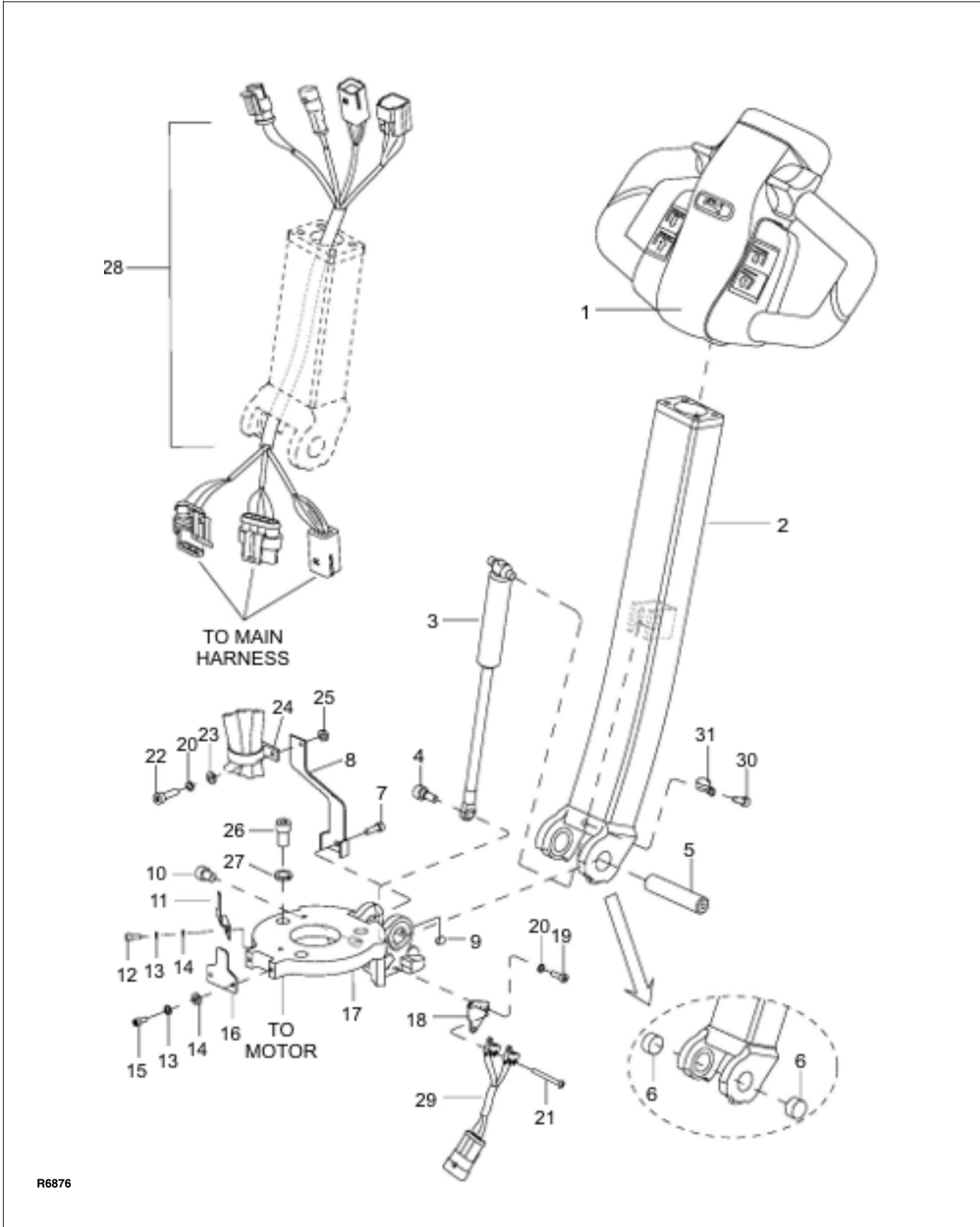

R6876

Figure 12-1 Steering System

INDEX NO.	PART NO.	PART NAME	NO. REQD.
1	—	CONTROL HEAD (FIGURE 12-2)	REF
2	1120-330000-0A	STEERING ARM	1
3	1120-320000-00	GAS SPRING	1
4	0000-000322-00	SCREW, M8 X 25	1
5	1120-300003-00	SHAFT	1
6	0000-000029-00	BUSHING	2
7	0000-000032-00	SCREW, M6 X 25	1
8	1120-300005-00	BRACKET	1
9	0000-000016-00	SCREW, M6 x 8	1
10	000-000030-00	SCREW, M10 X 16	1
11	1120-300007-00	BRACKET	1
12	0000-000117-00	SCREW, M5 X 10	1
13	0000-000206-00	WASHER, LOCK, M5	3
14	0000-000390-00	WASHER, FLAT, M5	3
15	0000-000004-00	SCREW, M5 X 12	2

INDEX NO.	PART NO.	PART NAME	NO. REQD.
16	1120-300004-00	FIXED PLATE	1
17	1120-300001-0A	BRAKE PLATE	1
18	1120-300006-00	BRACKET	1
19	0000-000088-00	SCREW, M4 X 8	2
20	0000-000122-00	WASHER, LOCK, M4	3
21	0000-000377-00	SCREW, M2 X 20	2
22	0000-000378-00	SCREW, M4 X 16	1
23	0000-000702-00	WASHER, FLAT, M4	1
24	0000-000491-00	CLAMP, PLASTIC	1
25	0000-000209-00	NUT, M4	1
26	0000-000109-00	SCREW, M8 X 16	3
27	0000-000159-00	WASHER, LOCK, M8	3
28	2320-520002-00	WIRING HARNESS	1
29	2112-520003-00	BRAKE SWITCH ASSY	1
30	0000-000010-00	SCREW, M5 X 6	1
31	0000-000490-00	CLAMP	1

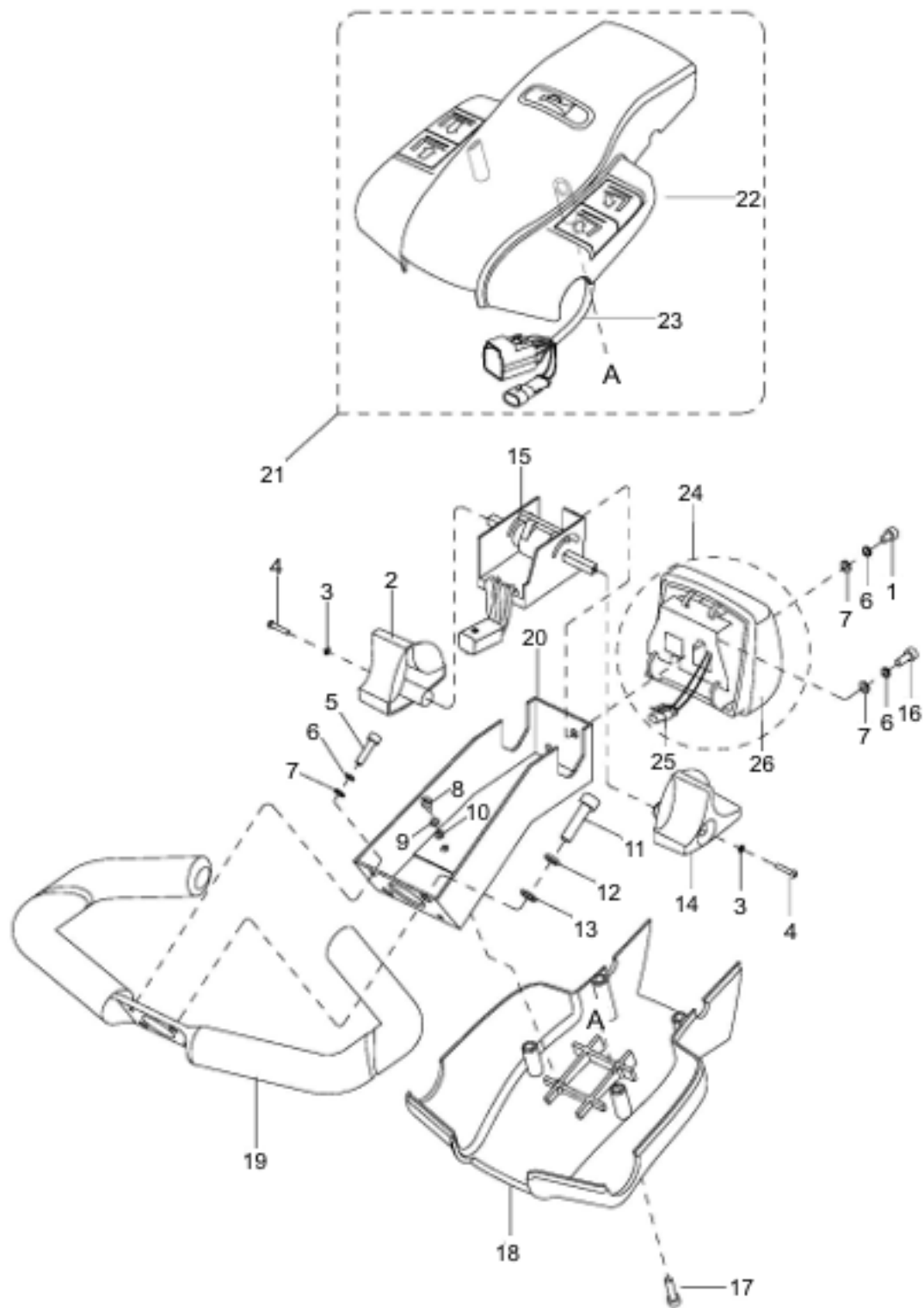

R6877

Figure 12-2 Control Head

INDEX NO.	PART NO.	PART NAME	NO. REQD.
—	2320-310000-00-B	CONTROL HEAD	1
1	0000-000010-00	• SCREW, M5 X 6	1
2	1120-340005-00	• CONTROL KNOB	2
3	0000-000038-00	• WASHER, LOCL, M3	2
4	0000-000037-00	• SCREW, M3 X 12	2
5	0000-000004-00	• SCREW, M5 X 12	2
6	0000-000206-00	• WASHER, LOCK, M5	4
7	0000-000390-00	• WASHER, FLAT, M5	4
8	0000-000088-00	• SCREW, M4 X 8	2
9	0000-000122-00	• WASHER, LOCK, M4	2
10	0000-000702-00	• WASHER, FLAT, M4	2
11	0000-000151-00	• SCREW, M8 X 25	2
12	0000-000159-00	• WASHER, LOCK, M8	2
13	0000-000176-00	• WASHER, FLAT, M8	2
14	1120-340003-00	• CONTROL KNOB	1
15	1220-520008-0C	• POTENTIOMETER	1

INDEX NO.	PART NO.	PART NAME	NO. REQD.
16	0000-000004-00	• SCREW, M5 X 12	2
17	0000-000035-00	• SCREW, M5 X 20	4
18	1120-340002-00	• COVER	1
19	1120-341000-00	• HANDLE	1
20	1120-340001-00	• BRACKET	1
21	2320-311000-00-B	• CAP ASSEMBLY	1
22	—	•• CAP ASSEMBLY (FIGURE 12-3)	REF
23	2320-520003-00	•• HARNESS ASSEMBLY	1
24	1120-343000-00-B	• EMERGENCY REVERSE SWITCH ASSY	1
25	1120-520005-0C	•• REVERSING SWITCH	1
26	—	•• EMERGENCY REVERSE SWITCH ASSY (FIGURE 12-4)	REF

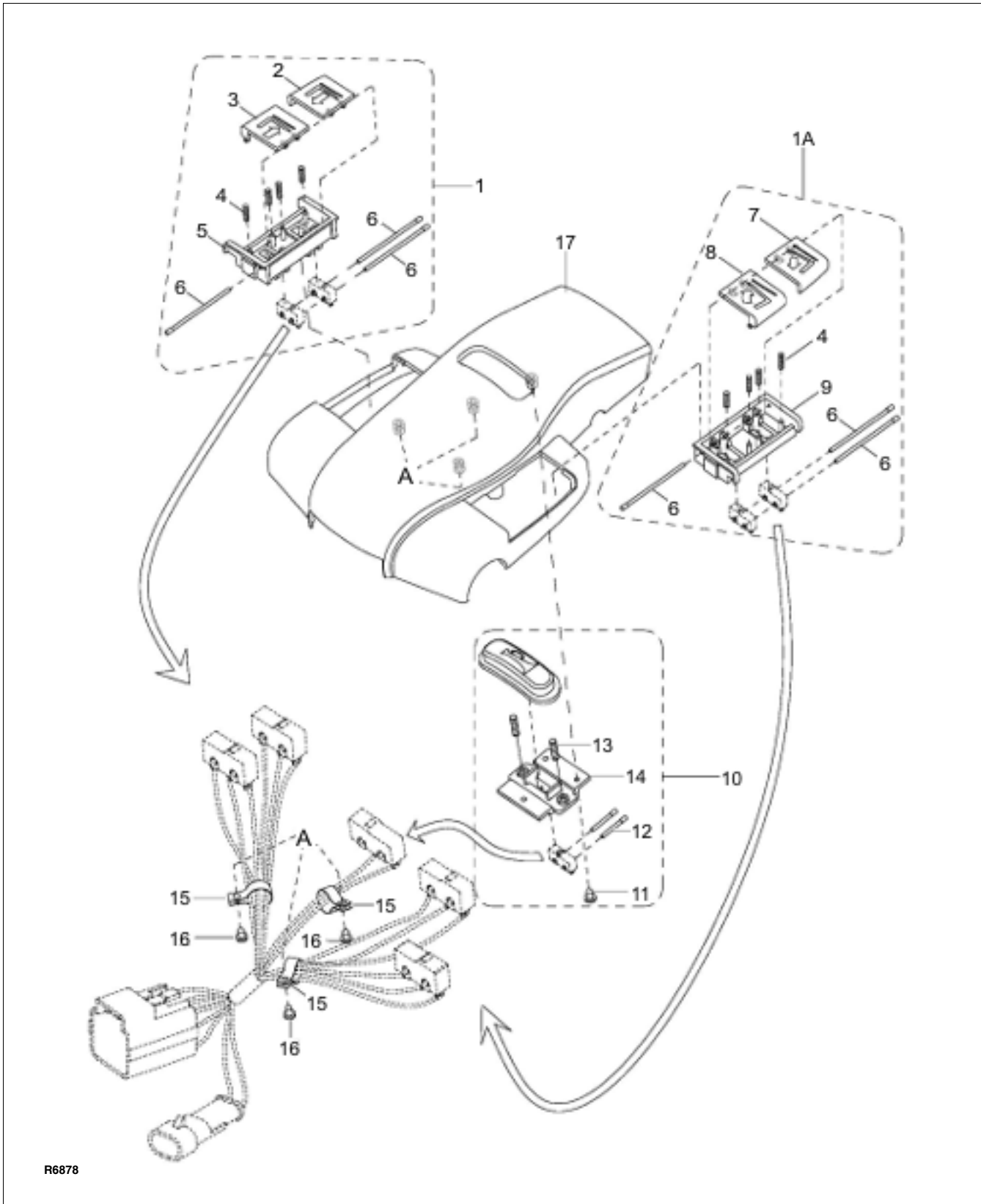

R6878

Figure 12-3 Cap Assembly

INDEX NO.	PART NO.	PART NAME	NO. REQD.
—	2320-311000-00	CAP ASSEMBLY	1
1	1120-342200-00	• LIFT/LOWERING SWITCH ASSY, RIGHT	1
1A	2320-311100-00	• TILT SWITCH ASSY, LEFT	1
2	1120-342203-00	• BUTTON, LOWERING, RIGHT	1
3	1120-342202-00	• BUTTON, LIFTING, RIGHT	1
4	1120-342102-00	• SPRING	8
5	1120-342201-00	• BRACKET, RIGHT	1
6	1120-342105-00	• PIN	6
7	2320-311101-00	• BUTTON, TILT BACK, LEFT	1

INDEX NO.	PART NO.	PART NAME	NO. REQD.
8	2320-311102-00	• BUTTON, TILT FORWARD, LEFT	1
9	1120-342101-00	• BRACKET, LEFT	1
10	1120-342002-00	• HORN BUTTON	1
11	0000-000039-00	•• SCREW, ST3.5 X 9.5	3
12	1120-342005-00	•• PIN	2
13	1120-342003-00	•• SPRING	2
14	1120-342004-00	•• BRACKET	1
15	0000-00490-00	• CLAMP	3
16	0000-000039-00	• SCREW, ST3.5 X 9.5	3
17	1120-342001-00	• COVER	1

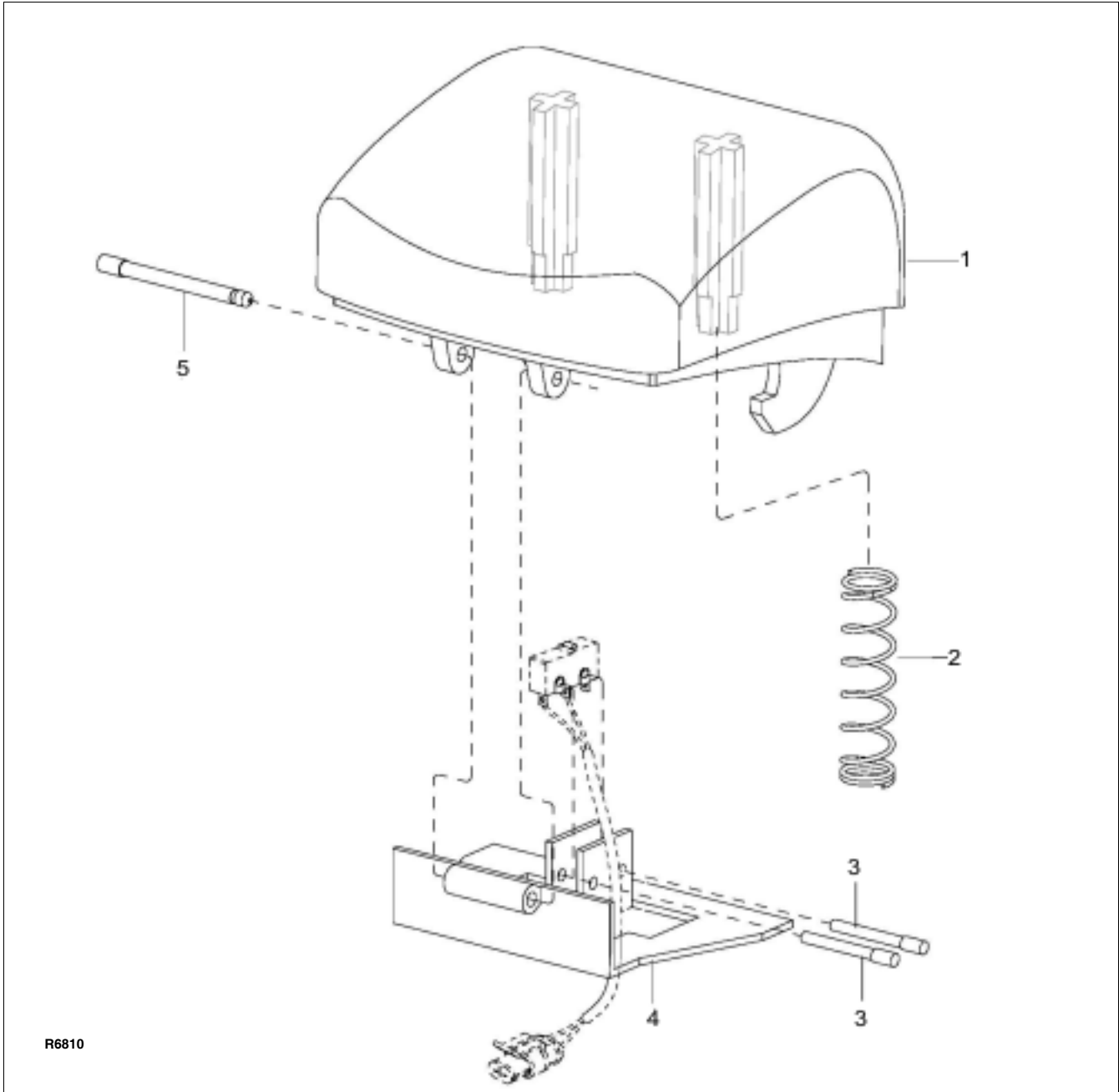
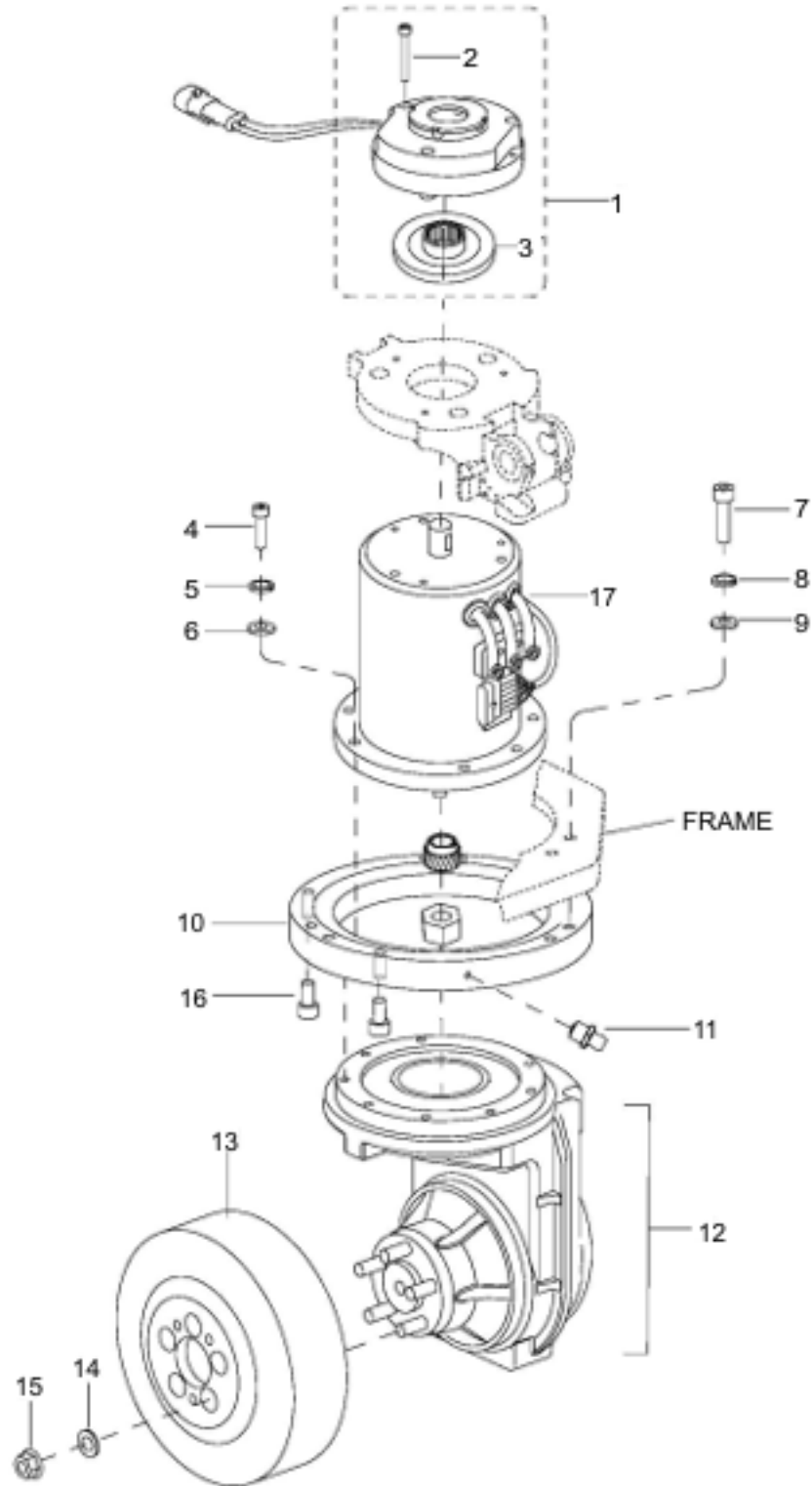

Figure 12-4 Emergency Reverse Switch Assembly

INDEX NO.	PART NO.	PART NAME	NO. REQD.
—	1120-343000-00	EMERGENCY REVERSE SWITCH ASSY	1
1	1120-343002-00	• EMERGENCY REVERSE BUTTON	1
2	1120-343003-00	• SPRING	2

INDEX NO.	PART NO.	PART NAME	NO. REQD.
3	1120-342005-00	• PIN	2
4	1120-343001-0A	• BRACKET	1
5	1120-343004-00	• PIN	1

NOTES



R6879

Figure 12-5 Transmission, Motor, Brake Assembly

INDEX NO.	PART NO.	PART NAME	NO. REQD.
1	1120-210000-00	BRAKE ASSEMBLY	1
2	0000-000027-00	• SCREW, M6 X 55	3
3	1120-210002-00	• ROTOR	1
4	0000-000169-00	SCREW, M8 X 30	8
5	0000-000159-00	WASHER, LOCK, M8	8
6	0000-000176-00	WASHER, FLAT, M8	8
7	0000-000155-00	SCREW, M10 X 40	6
8	0000-000063-00	WASHER, LOCK, M10	6
9	0000-000007-00	WASHER, FLAT, M10	6

INDEX NO.	PART NO.	PART NAME	NO. REQD.
10	1120-230000-00	BEARING	1
11	0000-000013-00	GREASE FITTING, M8	1
12	4230-210000-00	TRANSMISSION	1
13	1120-200001-00	DRIVE WHEEL	1
14	0000-000025-00	WASHER, LOCK, M12	5
15	0000-000157-00	NUT, M12	5
16	0000-999970-00	SCREW, M10 X 25	2
17	—	MOTOR, DRIVE (FIGURE 12-24)	REF

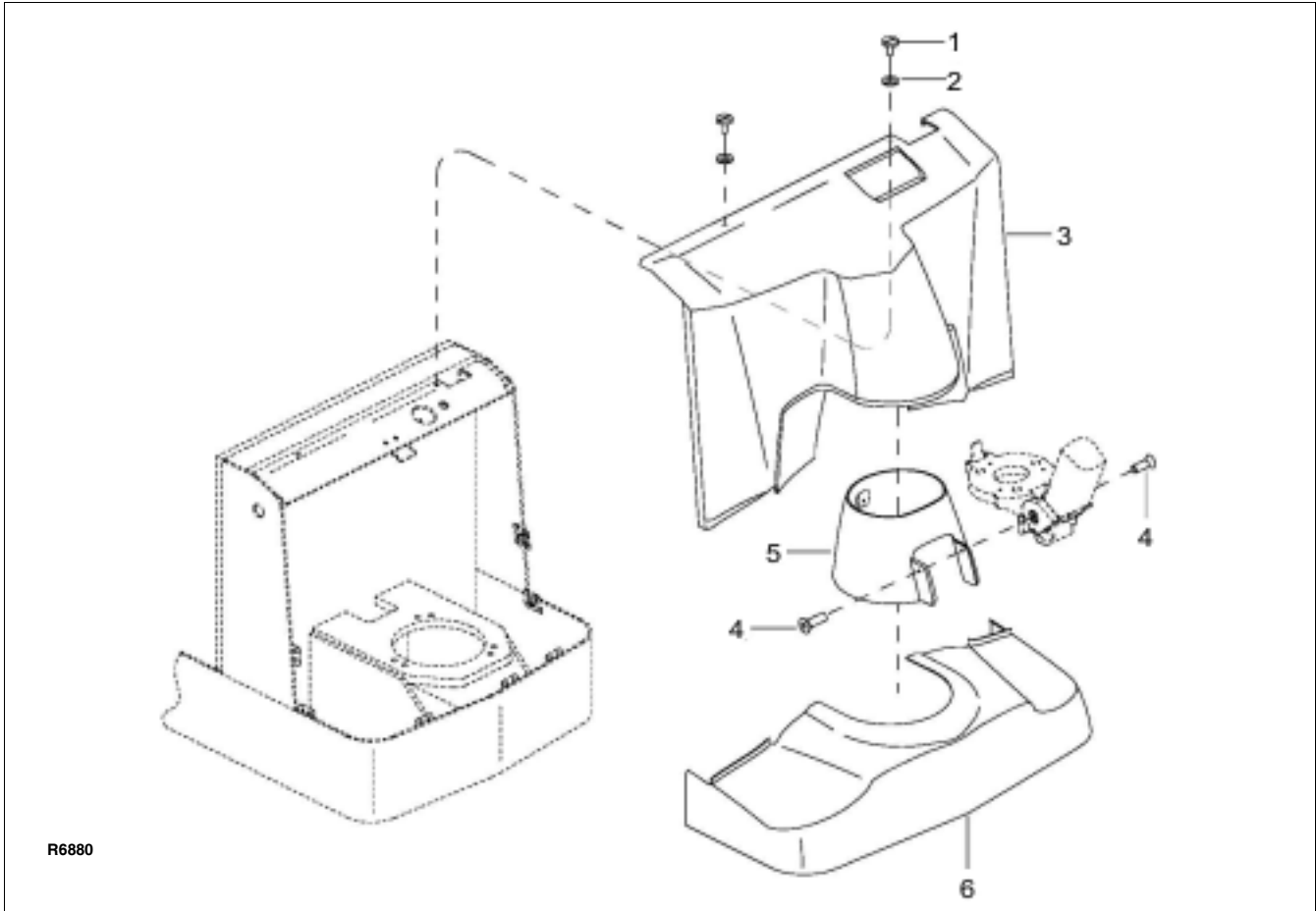

R6880

Figure 12-6 Compartment

INDEX NO.	PART NO.	PART NAME	NO. REQD.
1	0000-000368-00	SCREW, M8 X 12	2
2	2214-150002-00	WASHER	2
3	2125-140002-00	UPPER COVER	1

INDEX NO.	PART NO.	PART NAME	NO. REQD.
4	0000-000126-00	SCREW, M6 X 16	2
5	1120-150002-00	MIDDLE COVER	1
6	2125-140001-00	LOWER COVER	1

NOTES

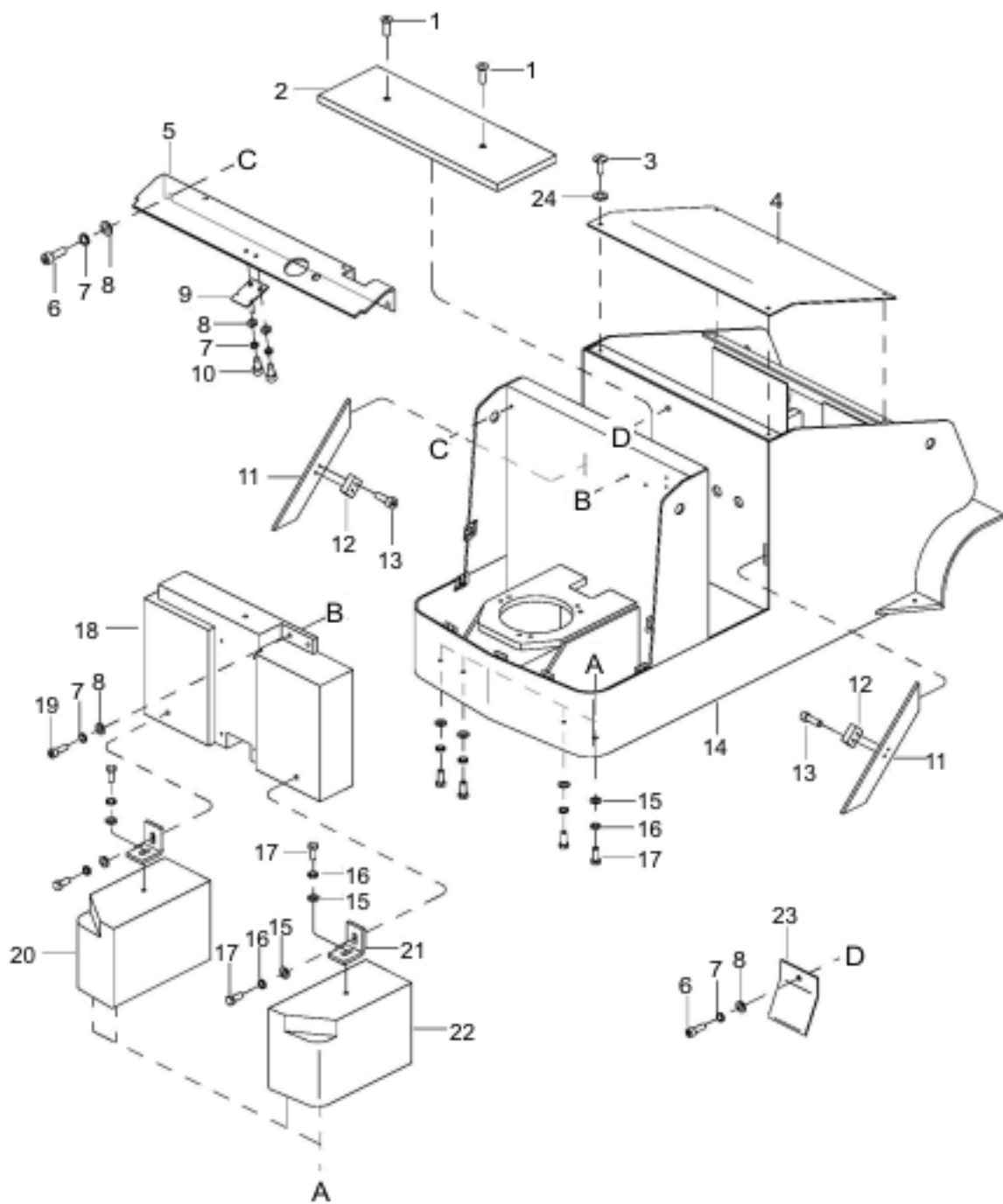

R6881

Figure 12-7 Frame

INDEX NO.	PART NO.	PART NAME	NO. REQD.
1	0000-000738-00	SCREW, M8 X 30	2
2	2320-100004-00	PLATE	1
3	0000-000368-00	SCREW, M8 X 12	4
4	2320-100002-00	COVER	1
5	2320-100001-00	TOP COVER	1
6	0000-000109-00	SCREW, M8 X 16	3
7	0000-000159-00	WASHER, LOCK, M8	7
8	0000-000176-00	WASHER, FLAT, M8	7
9	2125-100001-00	BRACKET	1
10	0000-000118-00	SCREW, M8 X 10	2
11	2320-100005-00	BAFFLE	2
12	1120-100004-00	BLOCK	2
13	0000-000015-00	SCREW, M6 X 10	4

INDEX NO.	PART NO.	PART NAME	NO. REQD.
14	2320-110000-00	FRAME	1
15	0000-000373-00	WASHER, FLAT, M12	8
16	0000-000060-00	WASHER, LOCK, M12	8
17	0000-000623-00	BOLT, M12 X 30	8
18	2320-140000-00	COUNTERWEIGHT, UPPER	1
19	0000-000026-00	SCREW, M8 X 30	2
20	2320-120000-00	COUNTERWEIGHT, LOWER	1
21	2320-100003-00	BRACKET	2
22	2320-130000-00	COUNTERWEIGHT, LOWER	1
23	2125-100002-00	BATTERY CLAMP	1
24	2214-150002-00	WASHER	4

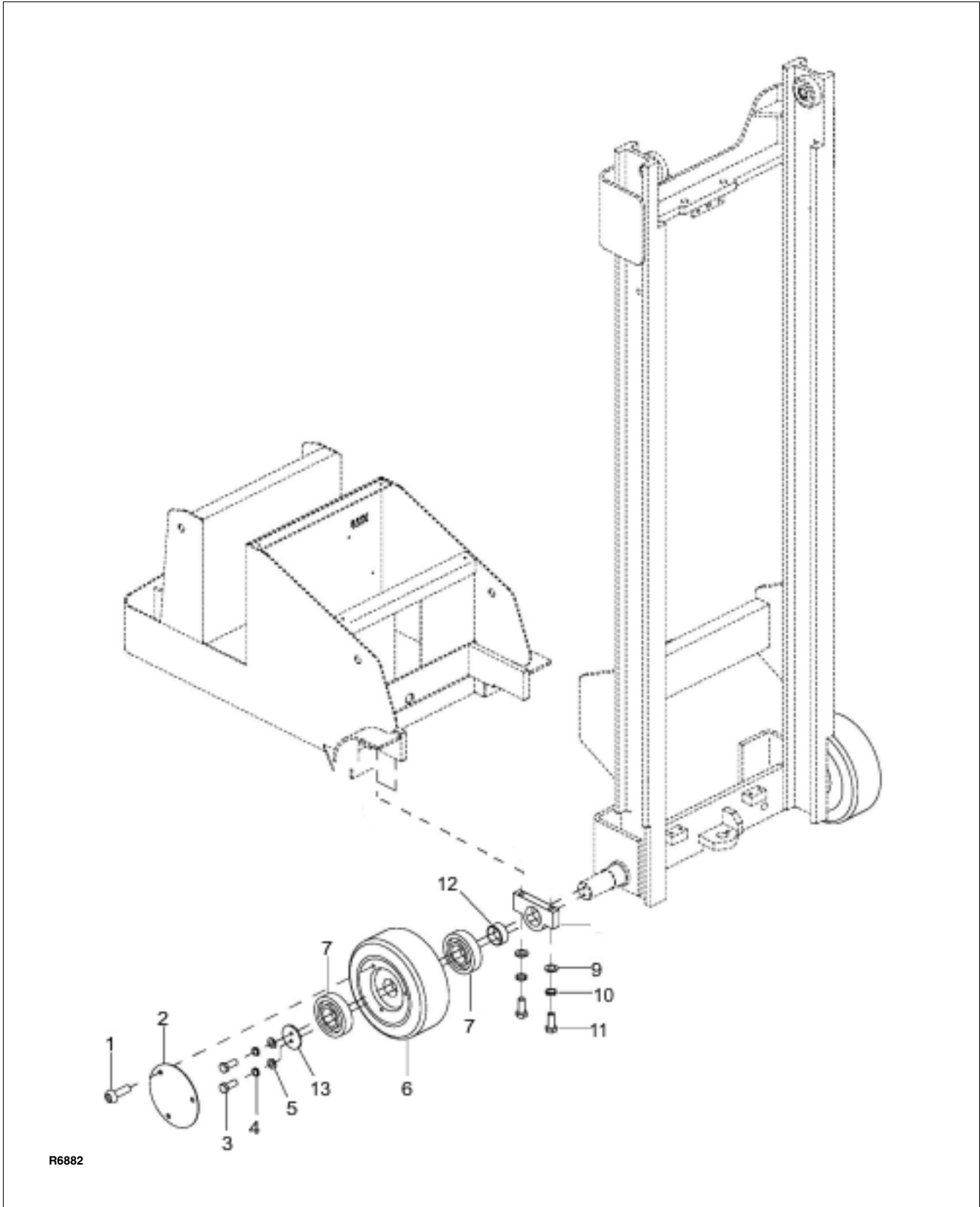
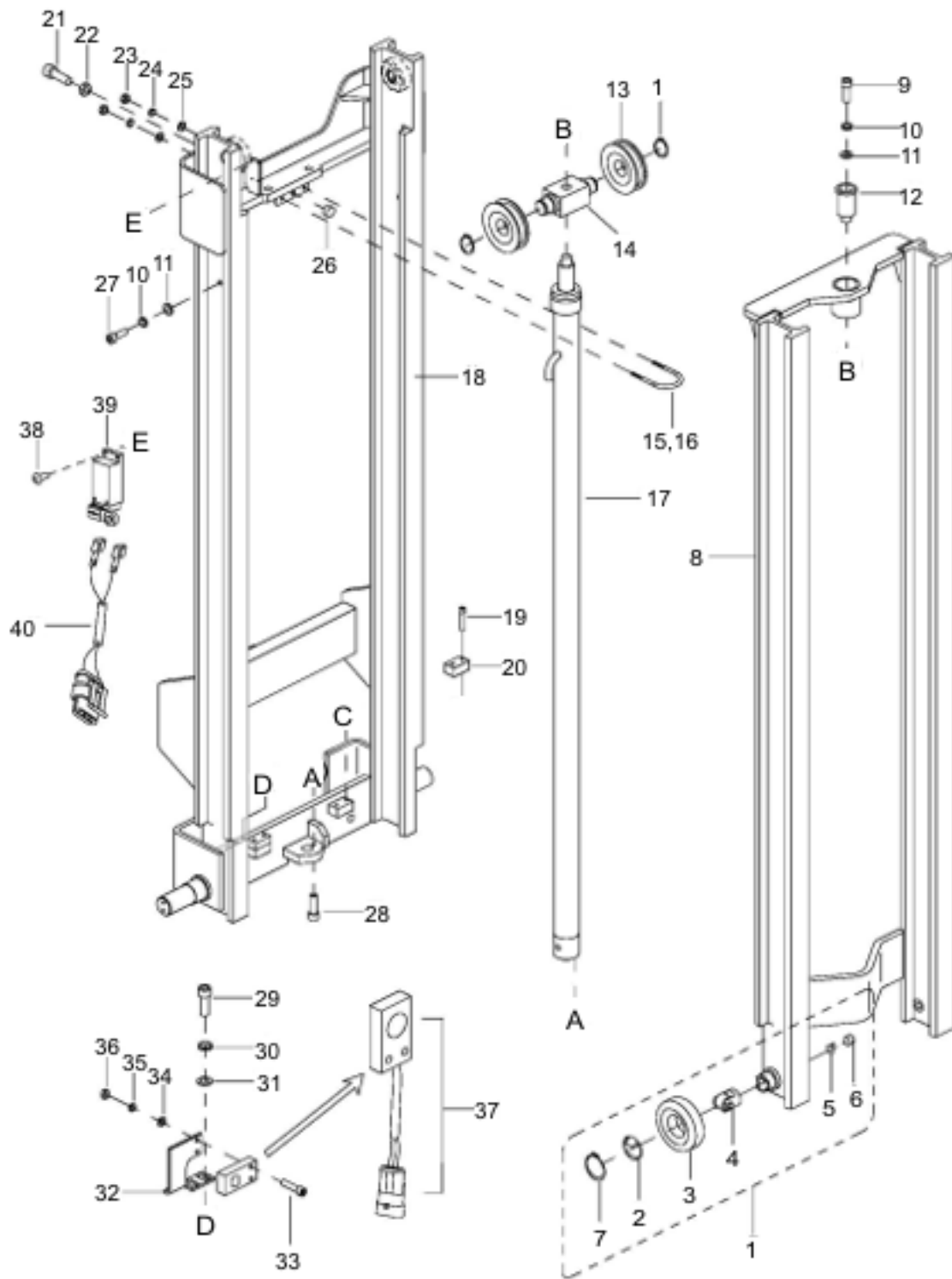

Figure 12-8 Load Wheels

INDEX NO.	PART NO.	PART NAME	NO. REQD.
1	0000-000851-00	SCREW, M8 X 12	6
2	2320-600003-00	COVER	2
3	0000-000620-00	BOLT, M6 X 16	4
4	0000-000056-00	WASHER, LOCK, M6	4
5	0000-000380-00	WASHER, FLAT, M6	4
6	2320-601100-00	LOAD WHEEL	2
7	0000-000857-00	BEARING 6309Z	4

INDEX NO.	PART NO.	PART NAME	NO. REQD.
8	2320-600001-00	BRACKET	2
9	0000-000233-00	WASHER, FLAT, M14	4
10	0000-000379-00	WASHER, LOCK, M14	4
11	0000-000848-00	BOLT, M14 X 85	4
12	0000-000858-00	BUSHING, 50 X 60 X 30	2
13	2320-600002-00	RETAINER	2



R6883

Figure 12-9 Elevation System (Telescopic)

INDEX NO.	PART NO.	PART NAME	NO. REQD.
1	2125-612000-00	ROLLER ASSEMBLY	4
2	2125-612005-00	• DUST SEAL	4
3	2125-612002-00	• ROLLER	4
4	2125-612001-00	• MAIN ROLLER	4
5	2125-612007-00	• SNAP RING	4
6	2125-612004-00	• SCREW	4
7	0000-000183-00	• RETAINING RING	6
8		INNER MAST	1
	2125-620000-00-01	(96 IN LIFT)	
	2125-620000-00-02	(104 IN LIFT)	
	2125-620000-00-03	(115 IN LIFT)	
	2125-620000-00-04	(127 IN LIFT)	
	2125-620000-00-05	(135 IN LIFT)	
	2125-620000-00-06	(139 IN LIFT)	
	2125-620000-00-07	(143 IN LIFT)	
	2125-620000-00-08	(151 IN LIFT)	
	2125-620000-00-09	(161 IN LIFT)	
9	0000-000184-00	SCREW, M12 X 60	1
10	0000-000060-00	WASHER, LOCK, M12	3
11	0000-000373-00	WASHER, FLAT, M12	3
12	2125-600003-00	POSITIONER	1
13	2125-600002-00	SHEAVES	2
14	2125-600001-00	RAM HEAD	1
15	2125-650001-00	CLAMP	1
16	2125-650003-00	CLAMP BUSHING	1
17	2000-937001	WASHER	4
17	—	LIFT CYLINDER ASSY (FIGURE 12-18)	REF
18		OUTER MAST	1
	2125-610000-00-01	(96 IN LIFT)	
	2125-610000-00-02	(104 IN LIFT)	
	2125-610000-00-03	(115 IN LIFT)	
	2125-610000-00-04	(127 IN LIFT)	
	2125-610000-00-05	(135 IN LIFT)	
	2125-610000-00-06	(139 IN LIFT)	
	2125-610000-00-07	(143 IN LIFT)	
	2125-610000-00-08	(151 IN LIFT)	
	2125-610000-00-09	(161 IN LIFT)	

INDEX NO.	PART NO.	PART NAME	NO. REQD.
19	0000-000001-00	SCREW, M6 X 20	4
20	2125-600005-00	BUFFER BLOCK	2
21	0000-000075-00	SCREW, M12 X 30	1
22	0000-000630-00	NUT, M12	1
23	0000-000108-00	NUT, M6	2
24	0000-000056-00	WASHER, LOCK, M6	2
25	0000-000380-00	WASHER, FLAT, M6	2
26	2125-650002-00	SCREW, BUSHING	1
27	0000-000374-00	SCRREW, M12 X 30	2
28	0000-000372-00	SCREW, M8 X 40	1
29	0000-000109-00	SCREW, M8 X 16	2
30	0000-000159-00	WASHER, LOCK, M8	2
31	0000-000176-00	WASHER, FLAT, M8	2
32	2125-500001-00	SENSOR BRACKRT	1
33	0000-000378-00	SCREW, M4 X 16	2
34	0000-000702-00	WASHER, FLAT, M4	2
35	0000-000122-00	WASHER, LOCK, M4	2
36	0000-000139-00	NUT, M4	2
37	2125-520003-0C	LIMIT SWITCH	1
38	0000-000518-00	SCREW, M5 X 6	4
39	2125-500003-00	LIFT LIMT SWITCH	1
40		SWITCH HARNESS	1
	2125-520009-26	(96, 104 IN LIFT)	
	2125-520009-29	(115, 127 IN LIFT)	
	2125-520009-31	(135, 139, 143 IN LIFT)	
	2125-520009-33	(151, 161 INCH LIFT)	

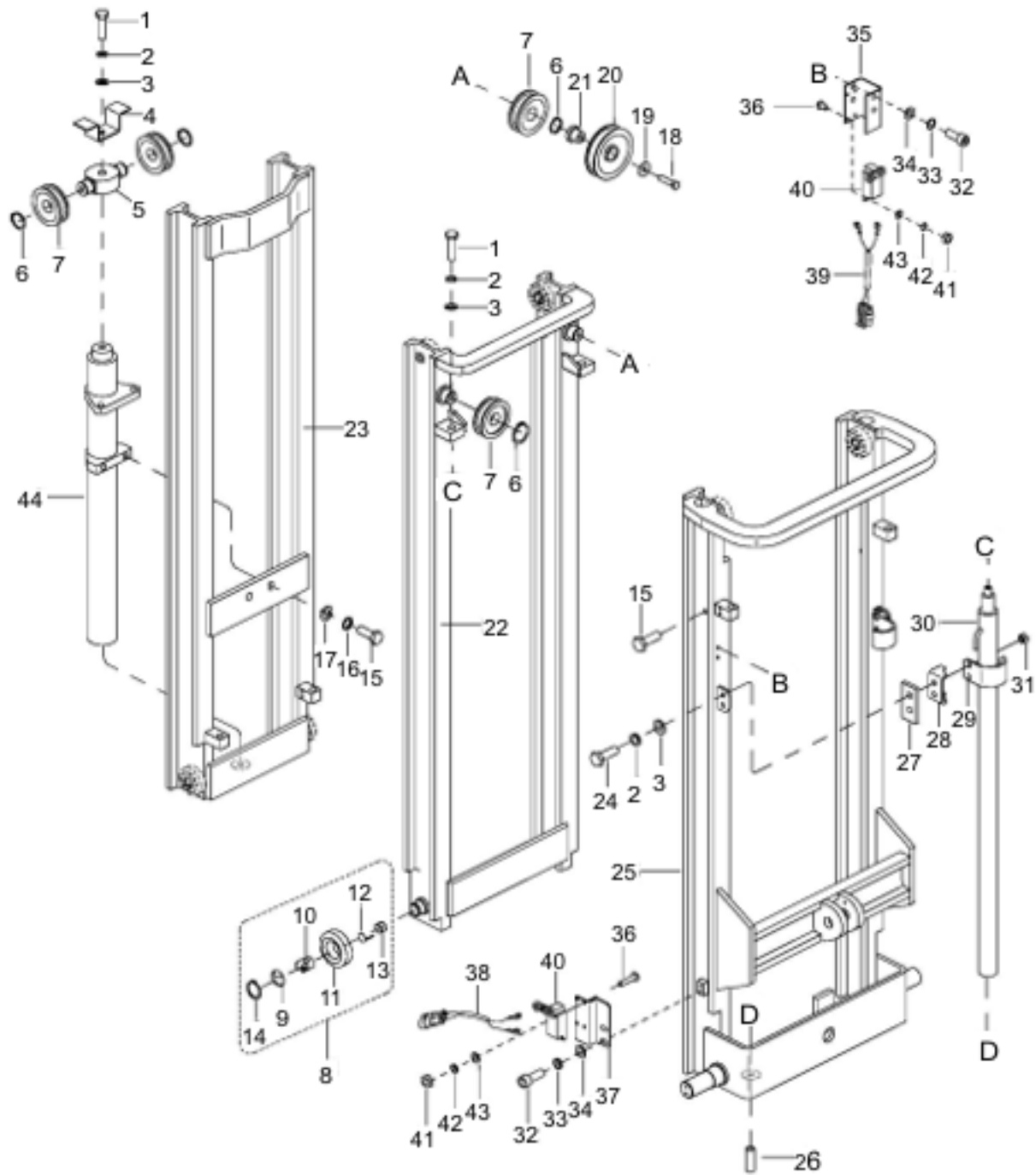

R6884

Figure 12-10 Elevation System (TRIMAST)

INDEX NO.	PART NO.	PART NAME	NO. REQD.
1	0000-000324-00	SCREW, M10 X 30	3
2	0000-000063-00	WASHER, LOCK, M10	7
3	0000-000551-00	WASHER, FLAT, M10	7
4	2125-600007-00	BRACKET	1
5	2125-600001-30	RAM HEAD	1
6	0000-000183-00	SNAP RING	2
7	2214-600001-00	SHEAVES	4
8	2125-612000-00	ROLLER ASSEMBLY	8
9	2125-612005-00	• DUST SEAL	8
10	2125-612002-00	• ROLLER	8
11	2125-612001-00	• MAIN ROLLER	8
12	2125-612007-00	• SNAP RING	8
13	2125-612004-00	• SCREW	8
14	0000-000183-00	• RETAINING RING	8
15	0000-000284-00	BOLT, M12 X 30	4
16	0000-000060-00	WASHER, LOCK, M12	2
17	0000-000373-00	WASHER, FLAT, M12	2
18	0000-000517-00	BOLT, M12 X 50	1
19	0000-000427-00	WASHER, FLAT, M12	1
20	2125-600002-00	SHEAVES	1
21	2125-600003-00	BUSHING	1
22		MIDDLE MAST	1
	2125-620000-30-01	(157 IN LIFT)	
	2125-620000-30-02	(177 IN LIFT)	
23		INNER MAST	1
	2125-630000-30-01	(157 IN LIFT)	
	2125-630000-30-02	(177 IN LIFT)	

INDEX NO.	PART NO.	PART NAME	NO. REQD.
24	0000-000244-00	BOLT, M10 X 30	1
25		OUTER MAST	1
	2125-610000-30-01	(157 IN LIFT)	
	2125-610000-30-02	(177 IN LIFT)	
26	0000-000026-00	SCREW, M8 X 30	2
27	2114-600005-00	SHIM	AR
28	2125-600006-30	BRACKET, CYLINDER	2
29	2125-600005-30	CLAMP	2
30	—	SECORDARY LIFT CYLINDER (FIGURE 12-20)	REF
31	0000-000425-00	NUT, M10	4
32	0000-000109-00	SCREW, M8 X 16	4
33	0000-000159-00	WASHER, LOCK, M8	4
34	0000-000176-00	WASHER, FLAT, M8	4
35	2125-500002-3A	SENSOR BRACKET	1
36	0000-000518-00	SCREW, M5 X 6	8
37	2125-500001-3A	SENSOR BRACKET	1
38	2125-520003-3A	HARNESS	1
39	0000-000374-00	SCREW, M12 X 30	2
40		HARNESS	1
	2125-52009-22	(157 IN LIFT)	
	2125-52009-24	(177 IN LIFT)	
41	0000-000546-00	NUT, M5	8
42	0000-000206-00	WASHER, LOCK, M5	8
43	0000-000390-00	WASHER, FLAT, M5	8
30	—	FREE LIFT CYLINDER (FIGURE 12-19)	REF

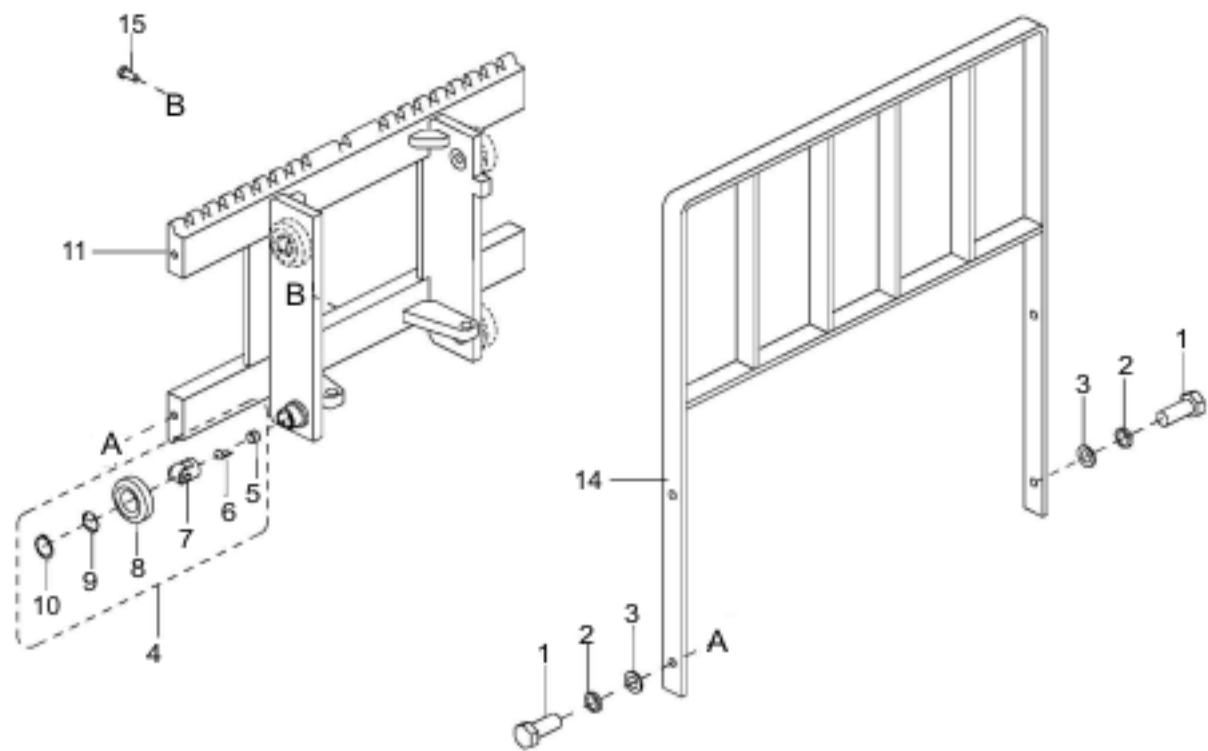
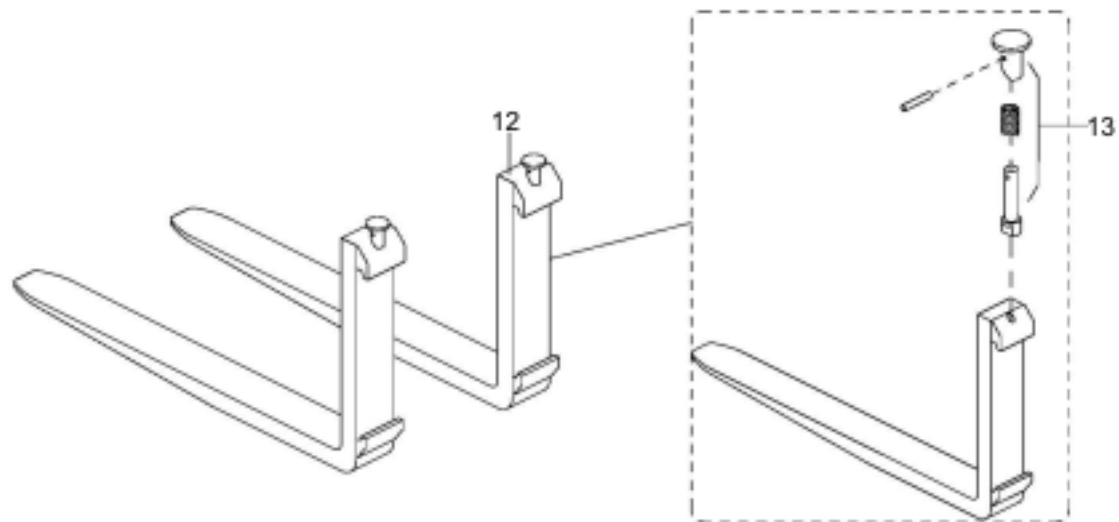

R6815

Figure 12-11 Lift Carriage

INDEX NO.	PART NO.	PART NAME	NO. REQD.
1	0000-000221-00	BOLT, M12 X 30	4
2	0000-000060-00	WASHER, LOCK, M12	4
3	0000-000373-00	WASHER, FLAT, M12	4
4	2125-631100-00	ROLLER ASSEMBLY	4
5	2125-631104-00	• SCREW	4
6	2125-612007-00	• SNAP RING	4
7	2125-612002-00	• ROLLER	4
8	2125-612001-00	• ROLLER	4

INDEX NO.	PART NO.	PART NAME	NO. REQD.
9	2125-612005-00	• DUST SEAL	4
10	0000-000183-00	• RETAINING RING	4
11	2125-631000-00	CARRIAGE (TELESCOPIC)	1
11	2320-640000-30	CARRIAGE (TRIMAST)	1
12	2125-630001-00	FORK	2
13	2125-630001-10	PIN	2
14	2125-632000-00	BACKREST	1
15	0000-000030-00	SCREW, M10 X 16	1

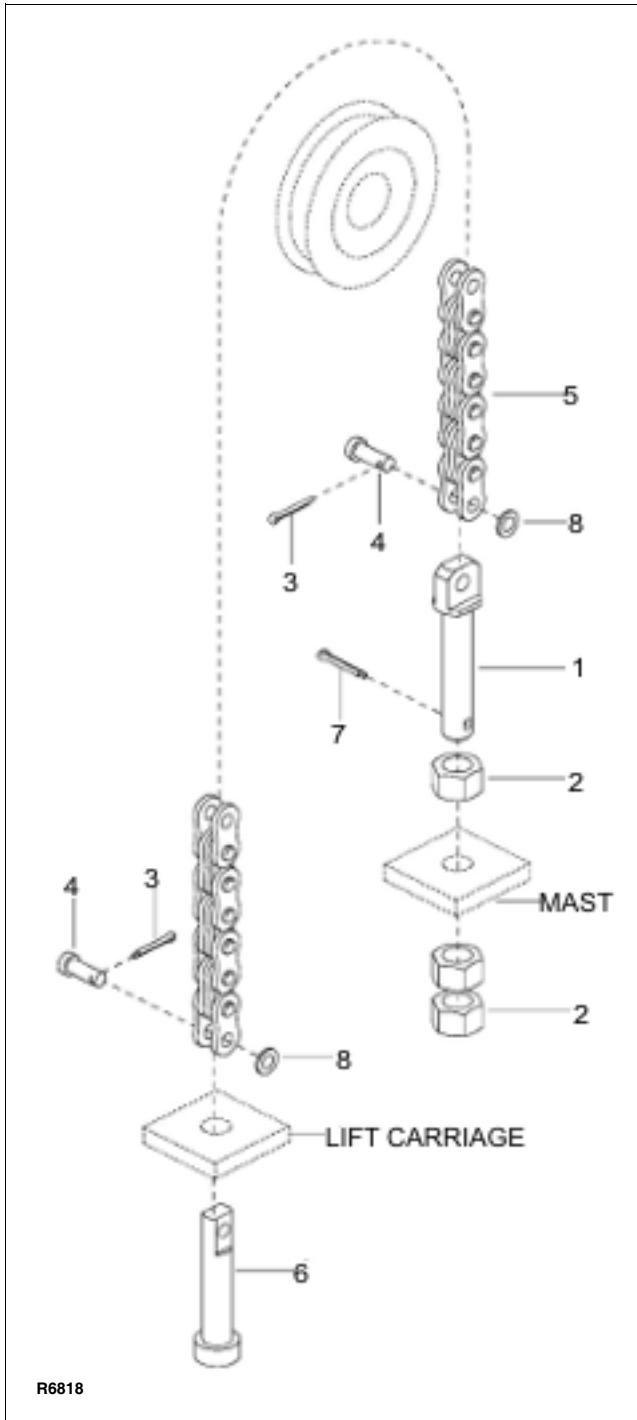
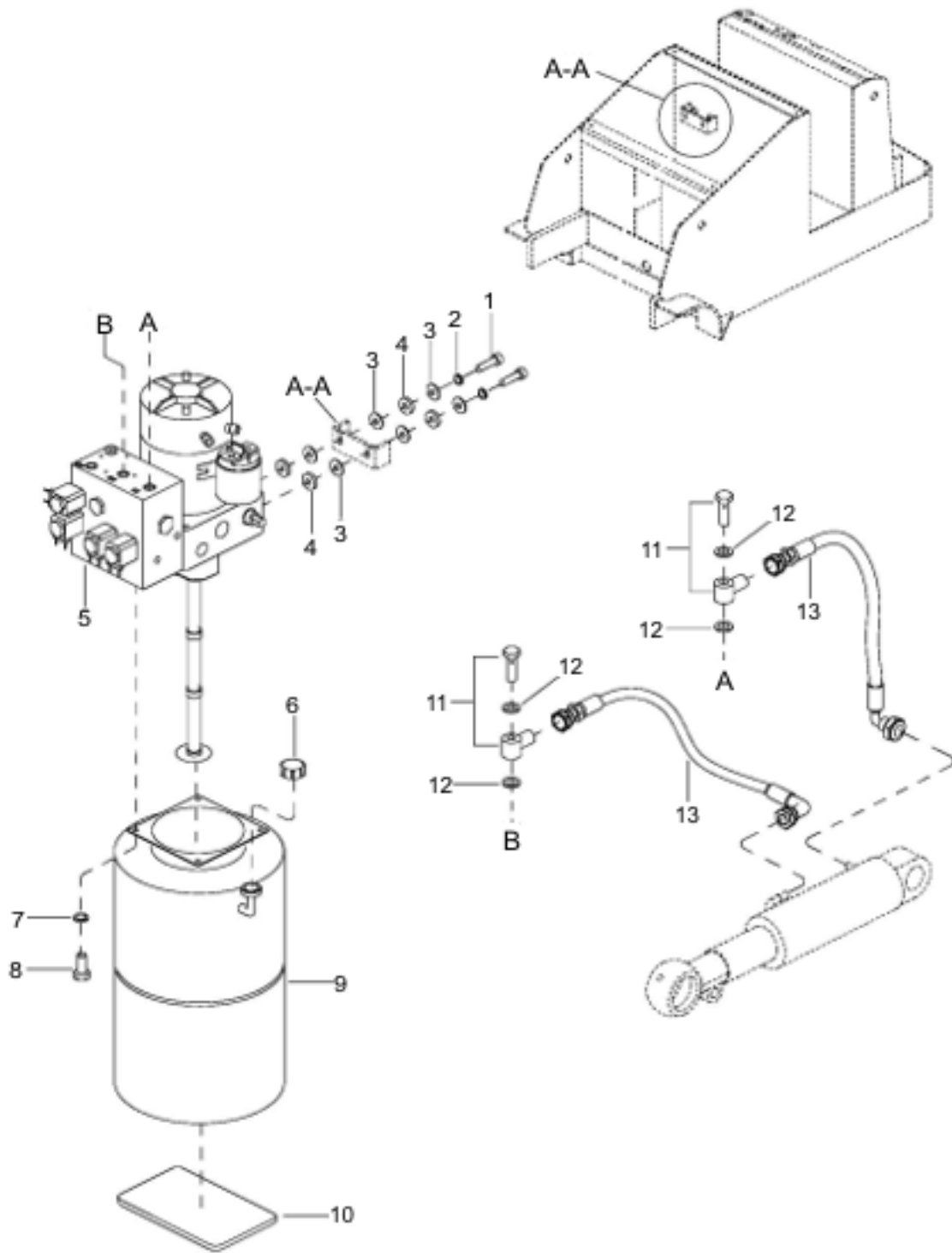

Figure 12-12 Chain Assembly

INDEX NO.	PART NO.	PART NAME	NO. REQD.
1	2125-640001-00	ADJUSTING SCREW (MAST)	1
2	0000-000187-00	NUT, M16 X 1.5	3
3	0000-000188-00	PIN, COTTER	2
4	2125-640002-00	PIN	2
5		CHAIN, TELESCOPIC	1
	2125-640000-00-01	(96 IN LIFT) (85 LINKS)	
	2125-640000-00-02	(104 IN LIFT) (91 LINKS)	
	2125-640000-00-03	(115 IN LIFT) (99 LINKS)	
	2125-640000-00-04	(127 IN LIFT) (107 LINKS)	
	2125-640000-00-05	(135 IN LIFT) (111 LINKS)	
	2125-640000-00-06	(139 IN LIFT) (115 LINKS)	
	2125-640000-00-07	(143 IN LIFT) (117 LINKS)	
	2125-640000-00-08	(151 IN LIFT) (123 LINKS)	
	2125-640000-00-09	(161 IN LIFT) (129 LINKS)	
5		CHAIN, TRIMAST FREE LIFT	
	2125-651000-30-01	(157 IN LIFT) (55 LINKS)	
	2125-651000-30-02	(177 IN LIFT) (63 LINKS)	
5		SECONDARY LIFT	
	2125-652000-30-01	(158 IN LIFT) (85 LINKS)	
	2125-652000-30-02	(177 IN LIFT) (97 LINKS)	
6	2125-640003-00	CHAIN ANCHOR	1
7	0000-000686-00	PIN, COTTER	1
8	0000-000176-00	WASHER, FLAT, M8	2

NOTES



R6665

Figure 12-13 Hydraulic System

INDEX NO.	PART NO.	PART NAME	NO. REQD.
1	000-000155-00	SCREW, M10 X 40	2
2	0000-000063-00	WASHER, LOCK, M10	2
3	0000-000007-00	WASHER, FLAT, M10	6
4	2112-410004-00	WASHER	4
5	2320-421000-00	PUMP AND MOTOR (FIGURE 12-14)	1
6	2320-423000-00	COVER	1

INDEX NO.	PART NO.	PART NAME	NO. REQD.
7	0000-000056-00	WASHER, LOCK, M6	4
8	0000-000620-00	BOLT, M6 X 16	4
9	2320-422000-00	HYDRAULIC RESERVOIR	1
10	2112-410005-00	SPACER	1
11	2702-141400-0A	BOLT CONNECTOR	2
12	0000-000044-00	SEAL	4
13	3130-730800-00	HOSE	2

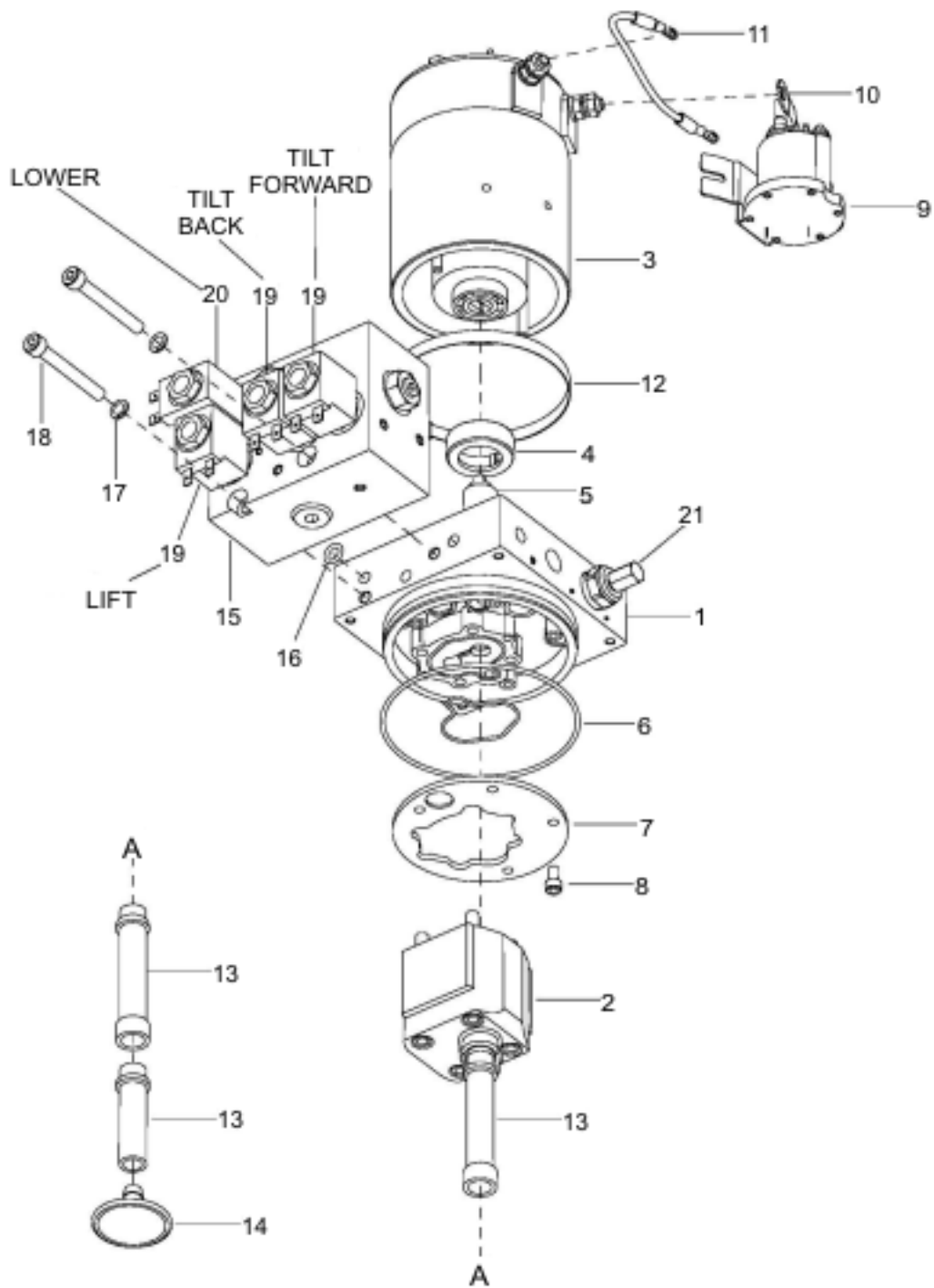

R6886

Figure 12-14 Pump & Motor

INDEX NO.	PART NO.	PART NAME	NO. REQD.
1	2320-421001-00	VALVE BODY	1
2	2320-421-002-00	PUMP	1
3	2320-421-003-00	MOTOR	1
4	2320-421004-00	BUSHING	1
5	2320-421005-00	COUPLIN	1
6	2320-421006-00	SEAL KIT	1
7	2320-421007-00	FILTER SCREEN	1
8	0000-000077-00	SCREW, M6 X 12	4
9	2320-421008-00	RELAY	1
10	2320-421009-00	BUS BAR	1
11	2320-421010-00	WIRE	1

INDEX NO.	PART NO.	PART NAME	NO. REQD.
12	2320-421011-00	CLAMP	1
13	2320-421012-00	TUBE, PLASTIC	3
14	2320-421013-00	FILTER, STEEL	1
15	2320-421014-00	MANIFOLD	1
16	2320-421015-00	O-RING	2
17	0000-000159-00	WASHER, LOCK, M8	2
18	0000-000110-00	SCREW, M8 X 65	2
19	2320-421016-00	SOLENOID VALVE	3
20	2320-421017-00	SOLENOID VALVE	1
21	2320-421018-00	RELIEF VALVE	1

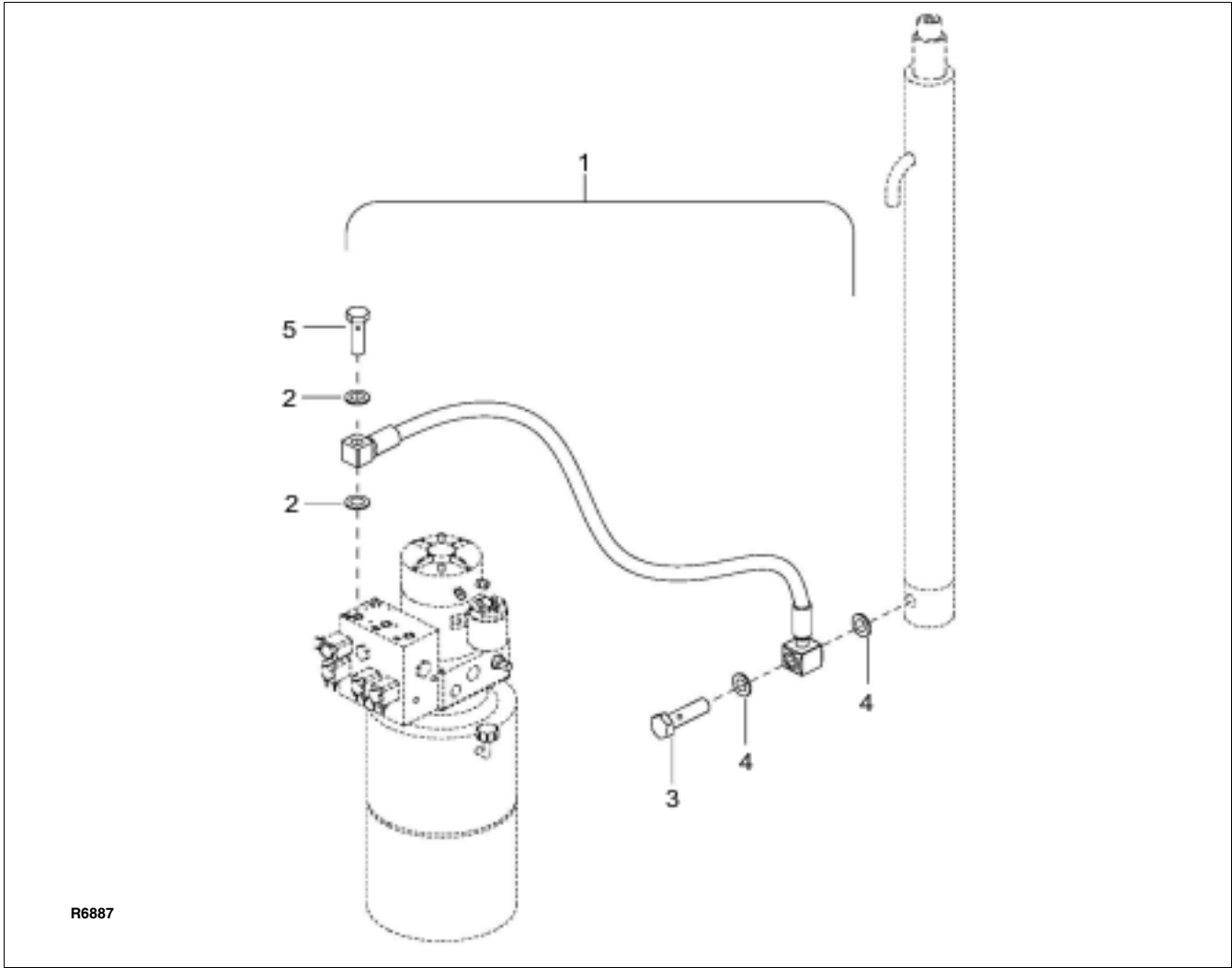
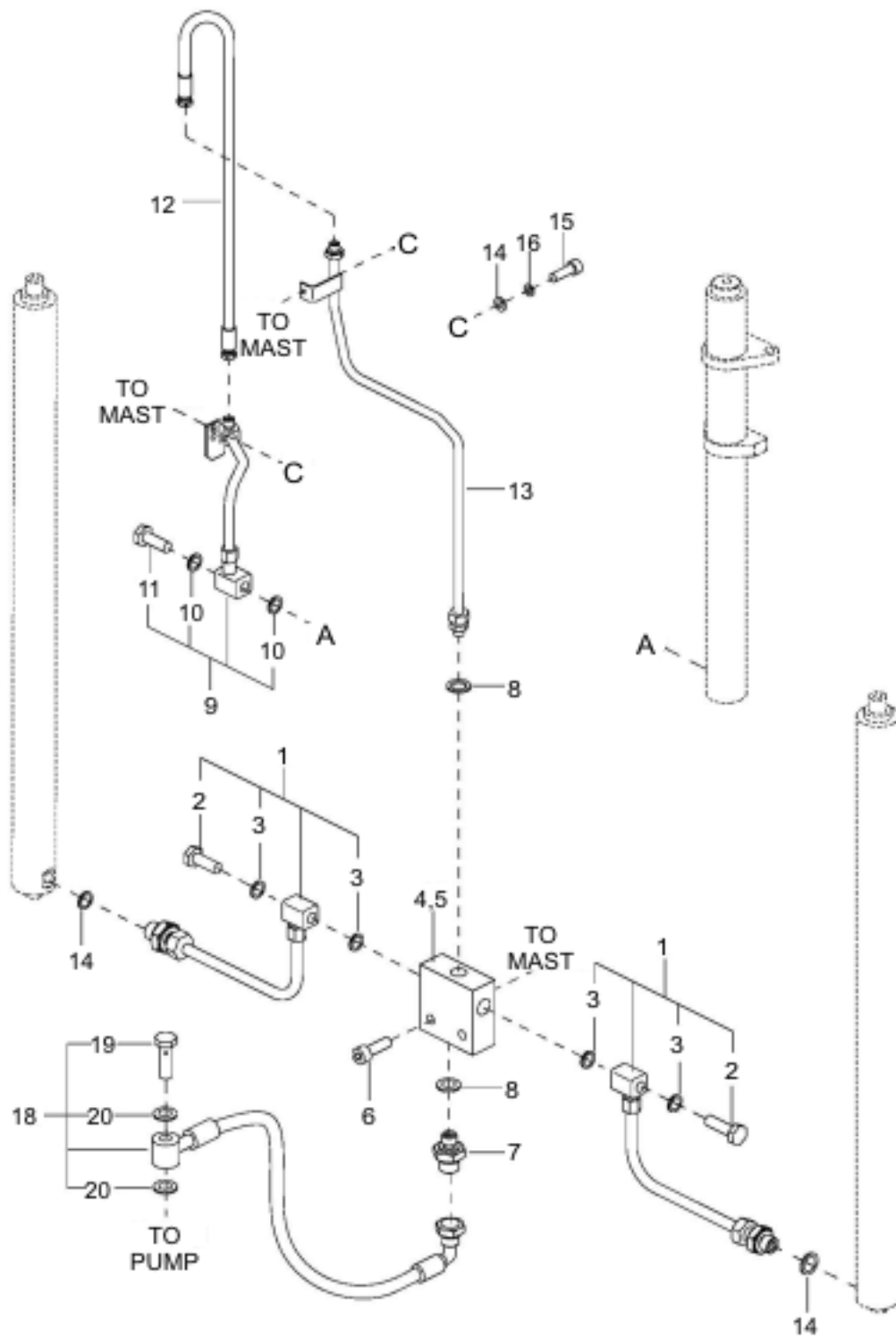

Figure 12-15 Hydraulic System (Telescopic)

INDEX NO.	PART NO.	PART NAME	NO. REQD.
1	2320-410000-00	HOSE ASSEMBLY	1
2	0000-000044-00	• SEAL	2
3	2401-163500-00	• BOLT, M16 X 35	1

INDEX NO.	PART NO.	PART NAME	NO. REQD.
4	0000-000069-00	• SEAL	2
5	2402-143500-00	• BOLT, G1/4 X 35	1

NOTES



R6888

Figure 12-16 Hydraulic System (TRIMAST)

INDEX NO.	PART NO.	PART NAME	NO. REQD.
1	2125-400001-3A-B	TUBE ASSEMBLY	2
2	2805-160010-20	• BOLT, M16 X 1.5	2
3	0000-000069-00	• SEAL	4
4	2125-400002-3A	MANIFOLD	1
5	2125-450000-00	RELIEF VALVE	2
6	0000-000154-00	SCREW, M8 X 35	2
7	2702-141600-00	CONNECTOR, G1/4 X 1.5	1
8	0000-000044-00	SEAL	2
9	2125-430000-3A-B	TUBE ASSEMBLY	1
10	0000-000069-00	• SEAL	2
11	2805-160014-00	• BOLT, M16 X 1.5 •	1

INDEX NO.	PART NO.	PART NAME	NO. REQD.
12		HOSE	1
	2125-440000-3A-01	(157 IN LIFT)	
	2125-440000-3A-03	(177 IN LIFT)	
13	2125-450000-30-B	TUBE	1
14	0000-000069-00	SEAL	2
15	0000-000109-00	SCREW, M8 X 16	3
16	0000-000159-00	WASHER, LOCK, M8	3
17	0000-000176-00	WASHER, FLAT, M8	3
18	2320-410000-30	HOSE ASSEMBLY	1
19	2402-143000-00	BOLT, G1/4 X 30	1
20	0000-000044-00	SEAL	2

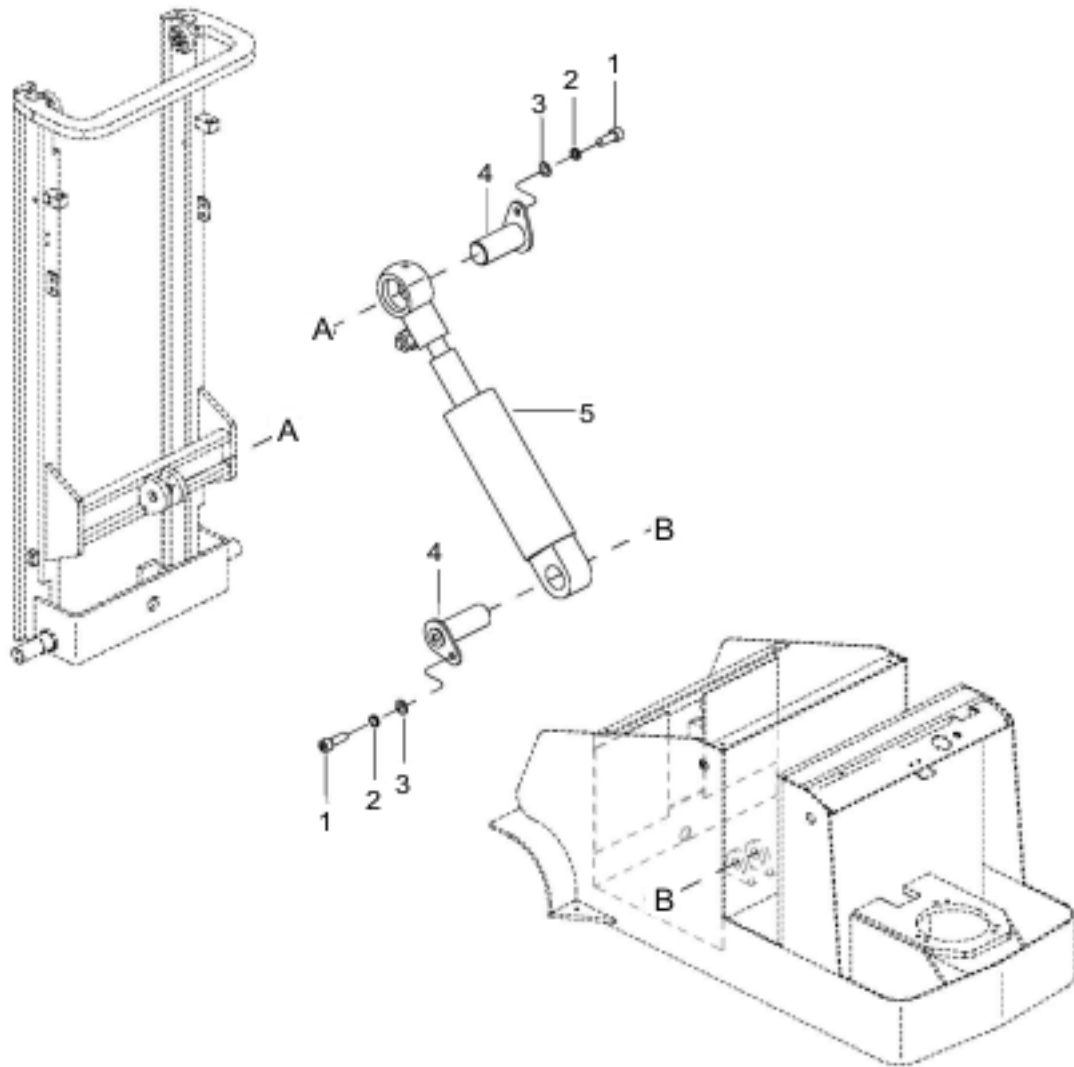

R6892

Figure 12-17 Tilt Cylinder Mounting

INDEX NO.	PART NO.	PART NAME	NO. REQD.
1	05782-08200A	BOLT, M8 X 20	2
2	0000-000159-00	WASHER, LOCK, M8	2
3	0000-000176-00	WASHER, FLAT, M8	2

INDEX NO.	PART NO.	PART NAME	NO. REQD.
4	3218-840000-00	SHAFT	2
5	—	CYLINDER, TILT (FIGURE 12-21)	REF

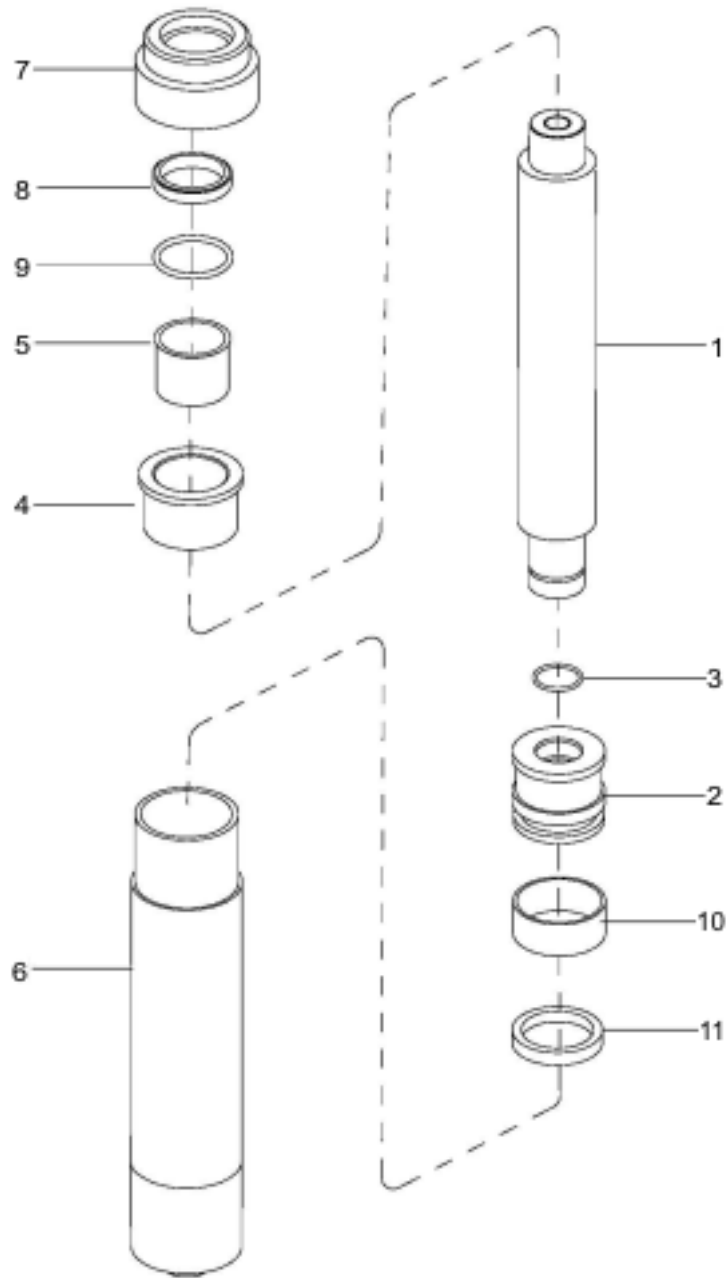

R6889

Figure 12-18 Lift Cylinder (Telescopic)

INDEX NO.	PART NO.	PART NAME	NO. REQD.
—	2110-410000-00-06	LIFT CYLINDER (96 IN LIFT)	1
—	2110-410000-00-02	LIFT CYLINDER (104 IN LIFT)	1
—	2110-410000-00-03	LIFT CYLINDER (115 IN LIFT)	1
—	2110-410000-00-05	LIFT CYLINDER (127 IN LIFT)	1
—	2110-410000-00-07	LIFT CYLINDER (135 IN LIFT)	1
—	2110-410000-00-08	LIFT CYLINDER (139 IN LIFT)	1
—	2110-410000-00-09	LIFT CYLINDER (143 IN LIFT)	1
—	2110-410000-00-10	LIFT CYLINDER (151 IN LIFT)	1
—	2110-410000-00-11	LIFT CYLINDER (161 IN LIFT)	1

INDEX NO.	PART NO.	PART NAME	NO. REQD.
1	—	• PISTON ROD	1
2	2125-410002-00	• PISTON	1
3	2125-410003-00	• COLLAR	1
4	2125-410006-00	• BUSHING	1
5	0000-000711-00	• BEARING, 3530	1
6	—	• CYLINDER TUBE	1
7	2125-410004-0a	• GLAND NUT	1
8	0000-000084-00	• WIPER RING	1
9	0000-000370-00	• O-RING	1
10	2125-410005-00	• BACKUP RING	1
11	0000-000512-00	• PACKING	1

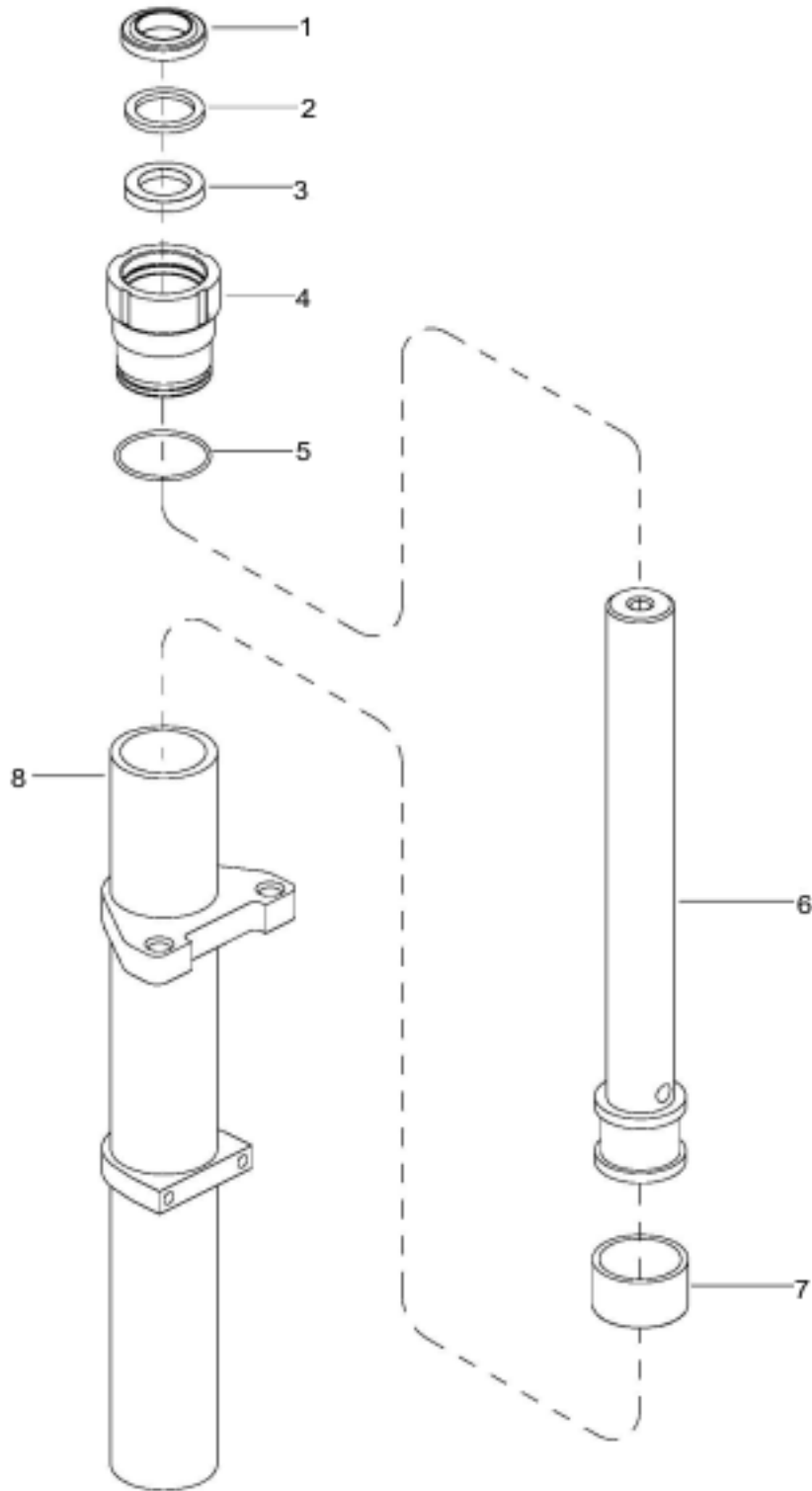

R6890

Figure 12-19 Free Lift Cylinder (TRIMAST)

INDEX NO.	PART NO.	PART NAME	NO. REQD.
—	2125-420000-30-01	LIFT CYLINDER (157 IN LIFT)	1
—	2125-420000-30-02	LIFT CYLINDER (177 IN LIFT)	1
1	0000-000045-00	• WIPER RING	1
2	0000-000684-00	• COLLAR	1

INDEX NO.	PART NO.	PART NAME	NO. REQD.
3	0000-000046-00	• PACKING	1
4	2125-420002-30	• GLAND NUT	1
5	0000-000685-00	• O-RING	1
6	—	• PISTON ROD	1
7	2125-420003-30	• BACKUP RING	1
8	—	• CYLINDER TUBE	1

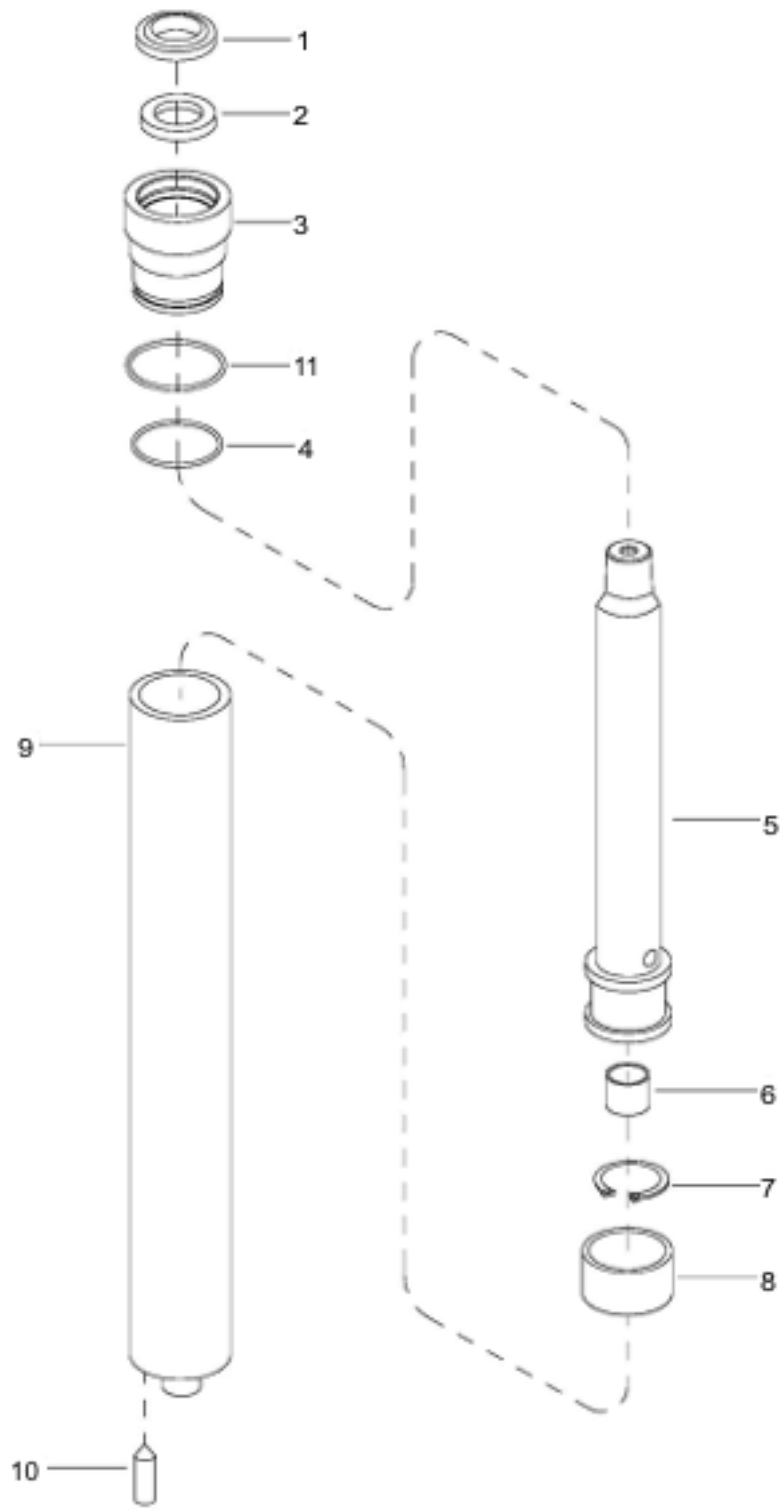

R6891

Figure 12-20 Secondary Lift Cylinder (TRIMAST)

INDEX NO.	PART NO.	PART NAME	NO. REQD.
—	2125-410000-30-01	LIFT CYLINDER (157 IN LIFT)	2
—	2125-410000-30-02	LIFT CYLINDER (177 IN LIFT)	2
1	0000-000084-00	• WIPER RING	1
2	0000-000085-00	• PACKING	1
3	2125-410004-30	• GLAND NUT	1
4	0000-000519-00	• O-RING	1

INDEX NO.	PART NO.	PART NAME	NO. REQD.
5	—	• PISTON ROD	1
6	2125-410005-30	• BUSHING	1
7	0000-000520-00	• RETAINING RING	1
8	2125-410002-30	• BACKUP RING	1
9	—	• CYLINDER TUBE	1
10	2125-410006-30	• PIN	1
11	0000-000609-00	• O-RING	1

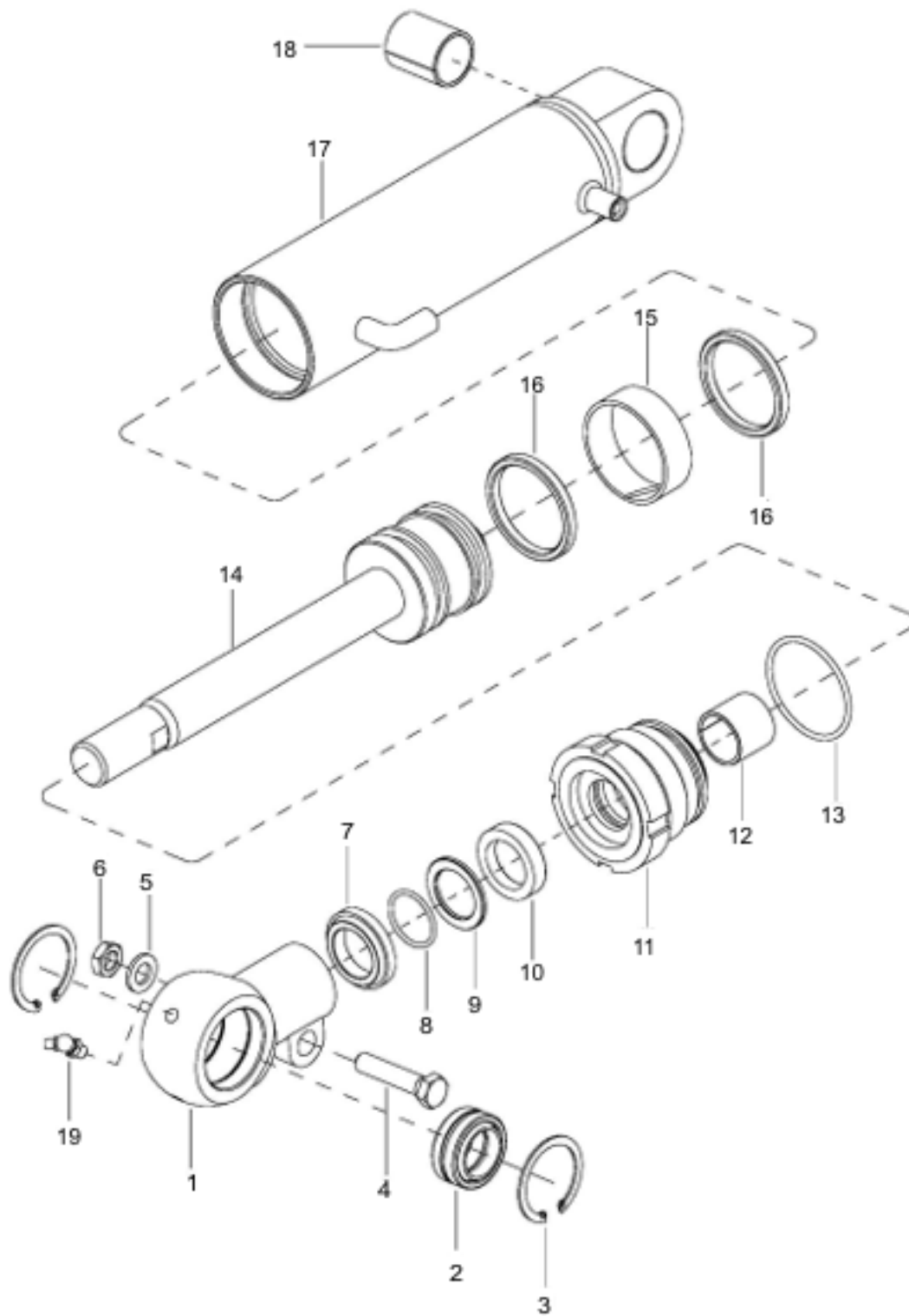

R6893

Figure 12-21 Tilt Cylinder

INDEX NO.	PART NO.	PART NAME	NO. REQD.
—	2320-430000-00	TILT CYLINDER	1
1	58603-15T11	• CLEVIS	1
2	3218-810008-00	• BEARING, GE30ES	1
3	0000-000849-00	• RETAINING RING	2
4	0000-000850-00	• BOLT, M14 X 1.5 X 45	1
5	0000-000233-00	• WASHER, LOCK	1
6	0000-000229-00	• NUT, M14 X 1.5	1
7	3218-810002-00	• DUST SEAL	1
8	3218-810006-00	• O-RING	1
9	58605-15T11	• SNAP RING	1

INDEX NO.	PART NO.	PART NAME	NO. REQD.
10	3218-810005-00	• SEAL	1
11	58602-15T11	• GLAND NUT	1
12	3218-810001--00	• BEARING	1
13	3218-810003-00	• O-RING	1
14	—	• PISTON ROD	1
15	58604-15T11	• WEAR RING	1
16	3218-810004-00	• SEAL	2
17	—	• CYLINDER TUBE	1
18	3218-810007-00	• BEARING, 3040	1
19	0000-000588-00	• GREASE FITTING	1

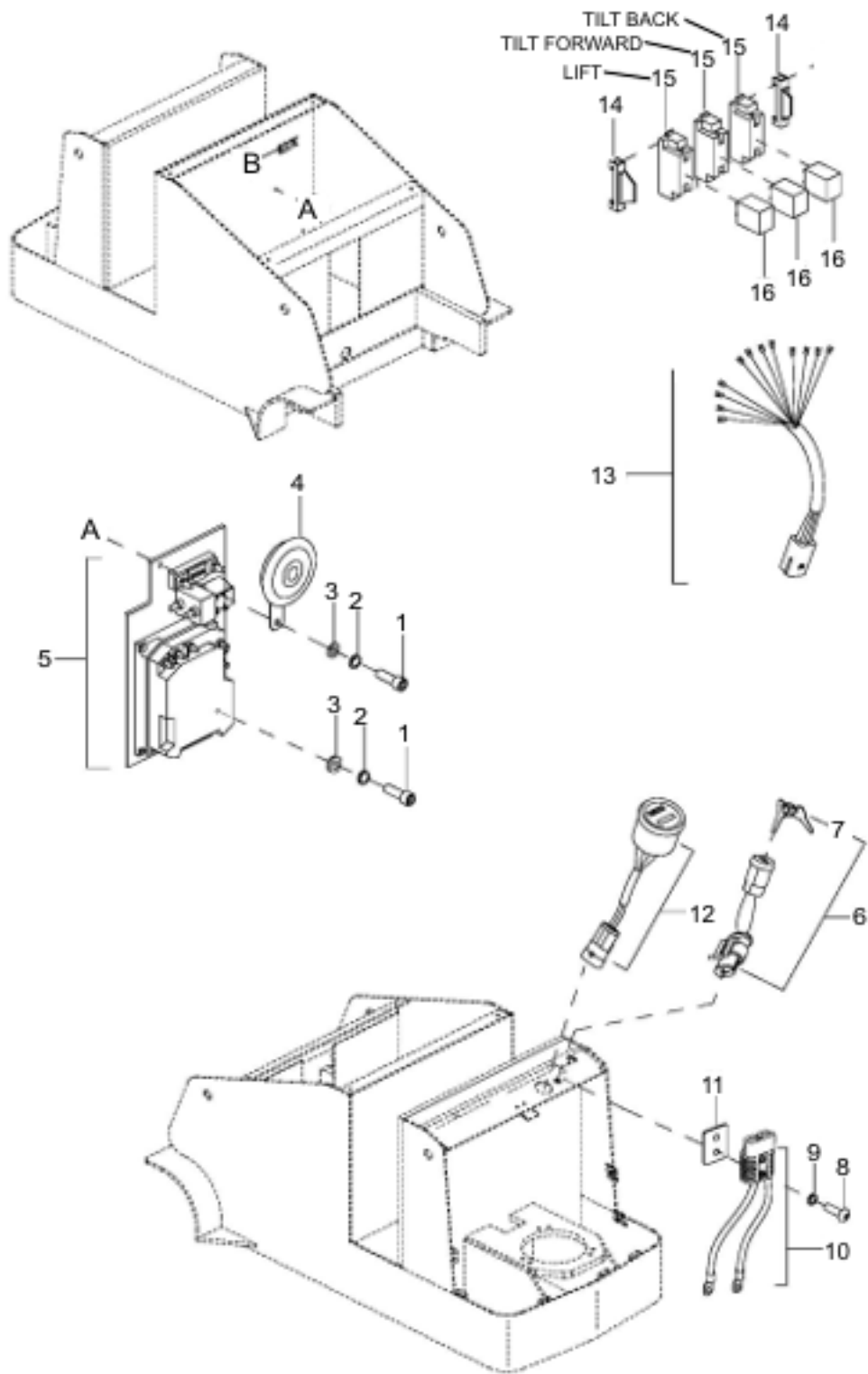

R6894

Figure 12-22 Electrical System

INDEX NO.	PART NO.	PART NAME	NO. REQD.
1	0000-000321-00	SCREW, M8 X 20	2
2	0000-000159-00	WASHER, LOCK, M8	2
3	0000-000194-00	WASHER, FLAT, M8	2
4	1120-500003-00	HORN	1
5	—	ELECTRICAL PANEL (FIGURE 12-23)	REF
6	1220-520002-0C	KEY SWITCH	1
7	1120-500016-00	• KEY	1
8	0000-000170-00	SCREW, M6 X 30	2

INDEX NO.	PART NO.	PART NAME	NO. REQD.
9	0000-000056-00	WASHER, LOCK, M6	2
10	2320-531000-00	CONNECTOR, BATTERY	1
11	1120-112008-00	SPACER	1
12	1220-520007-0C	BATTERY INDICATOR	1
13	2320-520005-00	RELAY HARNESS	1
14	2110-500003-00	RELAY CLIP	2
15	2110-500004-00	RELAY	3
16	2110-500005-00	RELAY	3

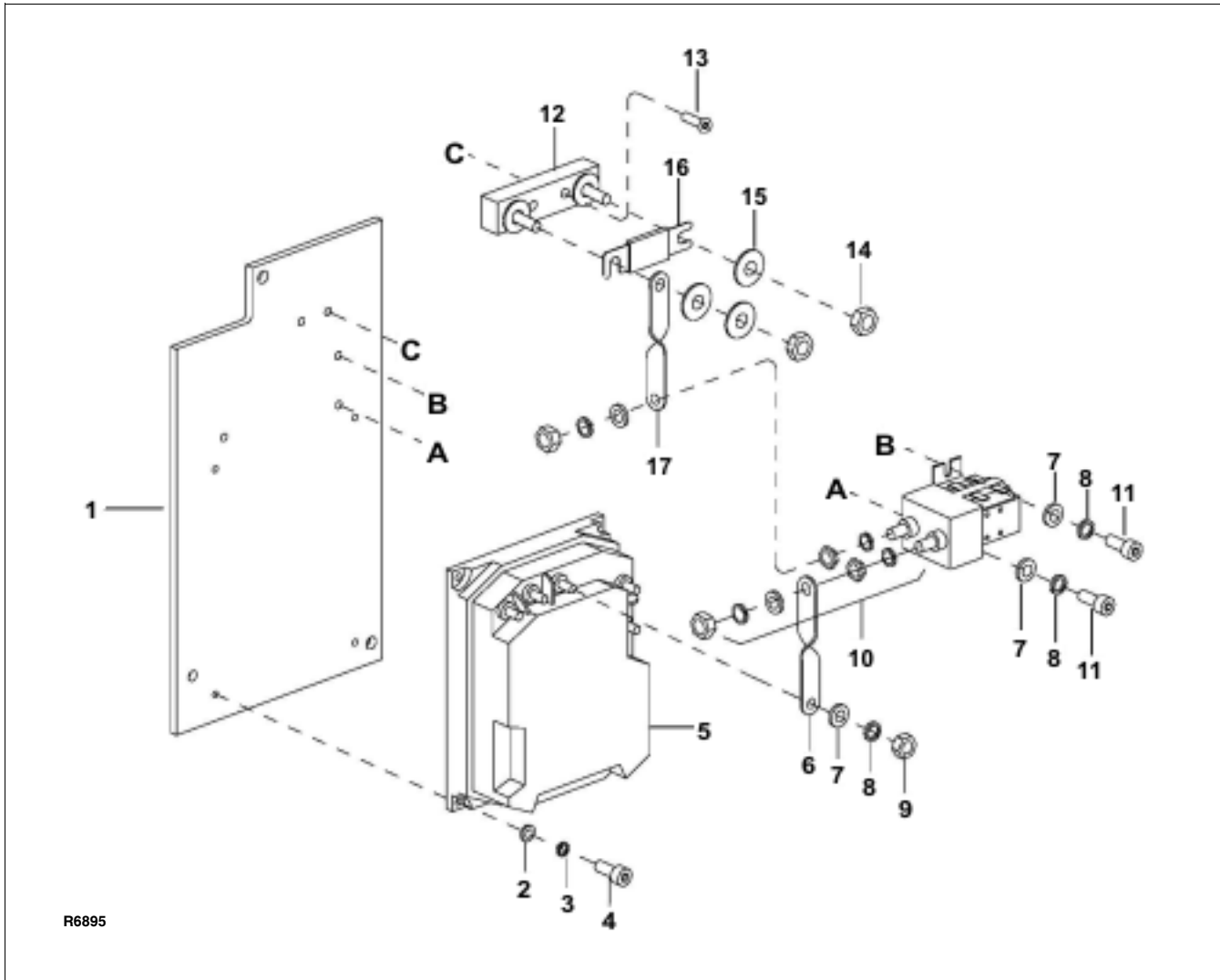

R6895

Figure 12-23 Electrical Panel

INDEX NO.	PART NO.	PART NAME	NO. REQD.
—	2125-510000-00	ELECTRICAL PANEL	1
1	2125-510001-00	• BOARD	1
2	0000-000128-00	• WASHER, FLAT, M5	4
3	0000-000206-00	• WASHER, LOCK, M5	4
4	0000-000004-00	• SCREW, M5 X 12	4
5	1120-500004-00	• CONTROLLER	1
6	1120-530007-00	• BUSS BAR	1
7	0000-000123-00	• WASHER, FLAT, M6	7
8	0000-000056-00	• WASHER, LOCK, M6	7

INDEX NO.	PART NO.	PART NAME	NO. REQD.
9	0000-000166-00	• NUT, M6	5
10	1120-500005-00	• CONTACTOR	1
11	0000-000077-00	• SCREW, M6 X 12	2
12	1120-540001-00-B	• FUSE HOLDER	1
13	0000-000090-00	• SCREW, M6 X 12	2
14	0000-000196-00	• NUT, M8	2
15	0000-000210-00	• WASHER, FLAT, M8	3
16	1120-540002-00	• FUSE, 200A	1
17	1120-530006-00	• BUSS BAR	1

NOTES

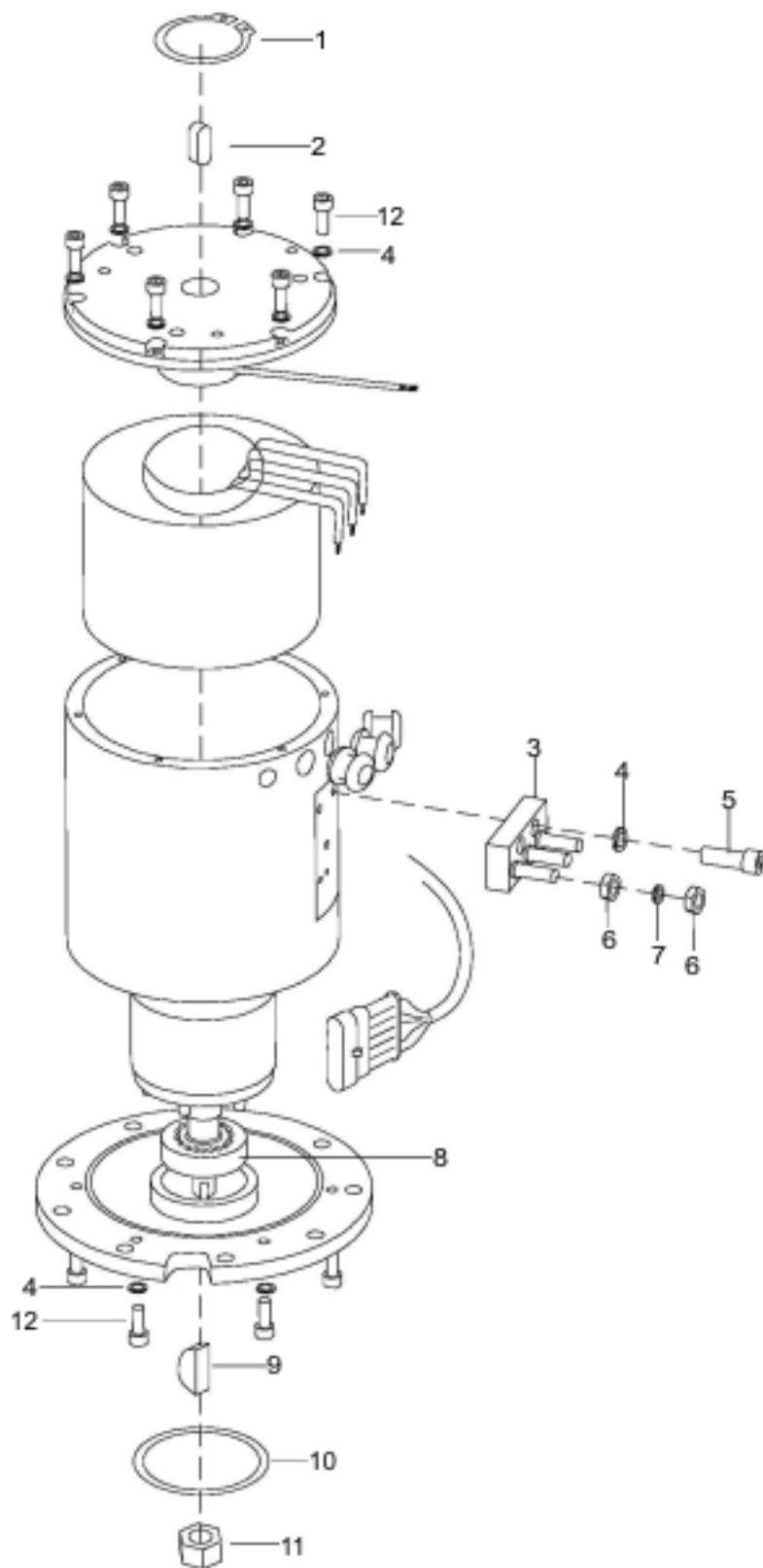

R6630

Figure 12-24 Drive Motor

INDEX NO.	PART NO.	PART NAME	NO. REQD.
—	1120-220000-00	DRIVE MOTOR	1
1	0000-000293-00	• RETAINING RING	2
2	0000-000226-00	• KEY, 6 X 6 X 16	1
3	1120-220001-00	• TERMINAL BLOCK	1
4	0000-000206-00	• WASHER, LOCK, M5	17
5	0000-000117-00	• SCREW, M5 X 10	2
6	0000-000166-00	• NUT, M6	6

INDEX NO.	PART NO.	PART NAME	NO. REQD.
7	0000-000056-00	• WASHER, LOCK, M6	6
8	1120-220002-00	• BEARING	1
9	0000-000204-00	• KEY, 3 x 5 x 13	1
10	0000-000409-00	• O-RING, 63 X 3.55	1
11	0000-000436-00	• NUT, M12 X 1.5	1
12	0000-000323-00	• SCREW, M5 X 16	14

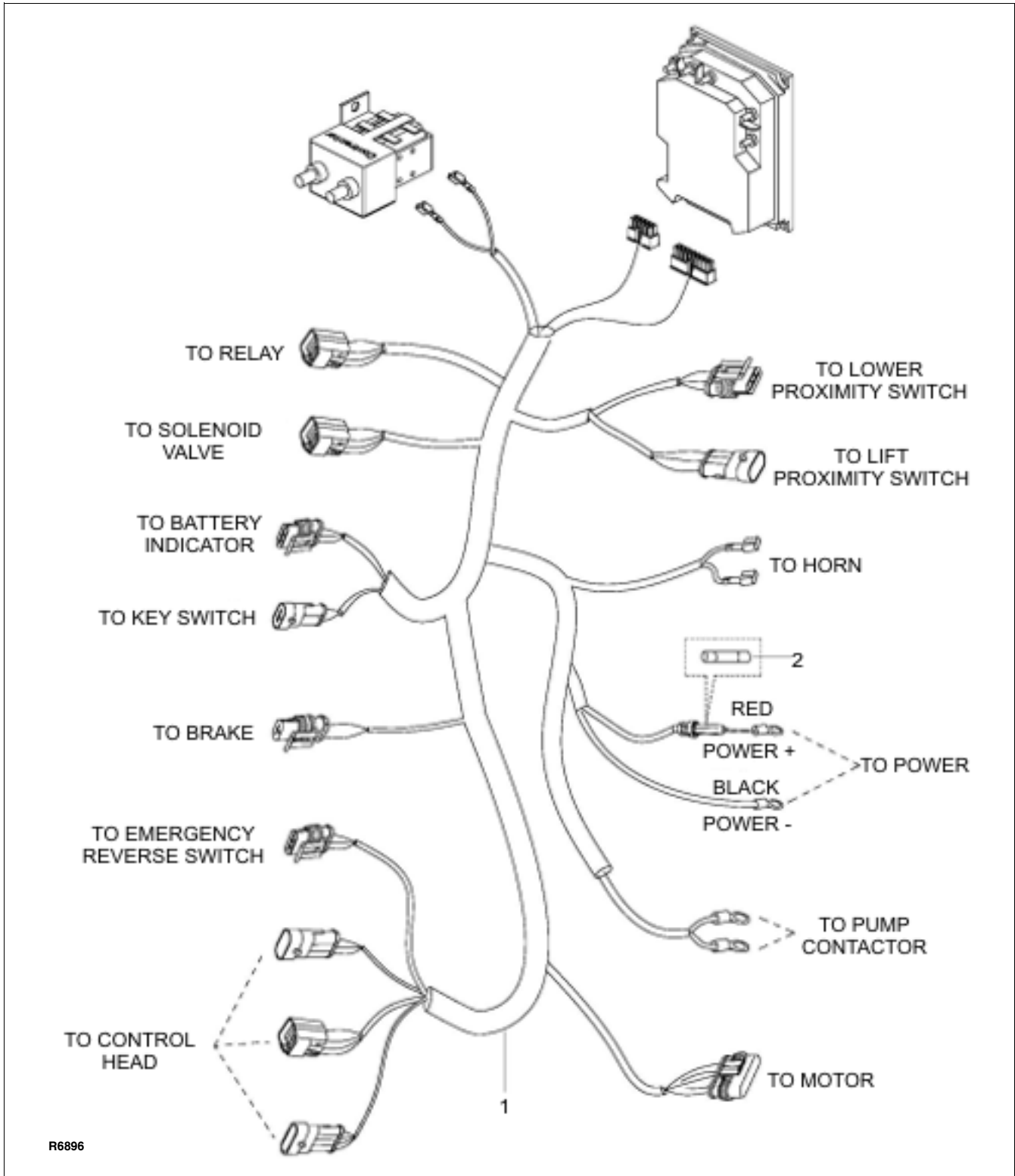

R6896

Figure 12-25 Wiring Harness

INDEX NO.	PART NO.	PART NAME	NO. REQD.
1	2320-520001-00	WIRE HARNESS	1

INDEX NO.	PART NO.	PART NAME	NO. REQD.
2	1120-500010-00	FUSE, 10A	1

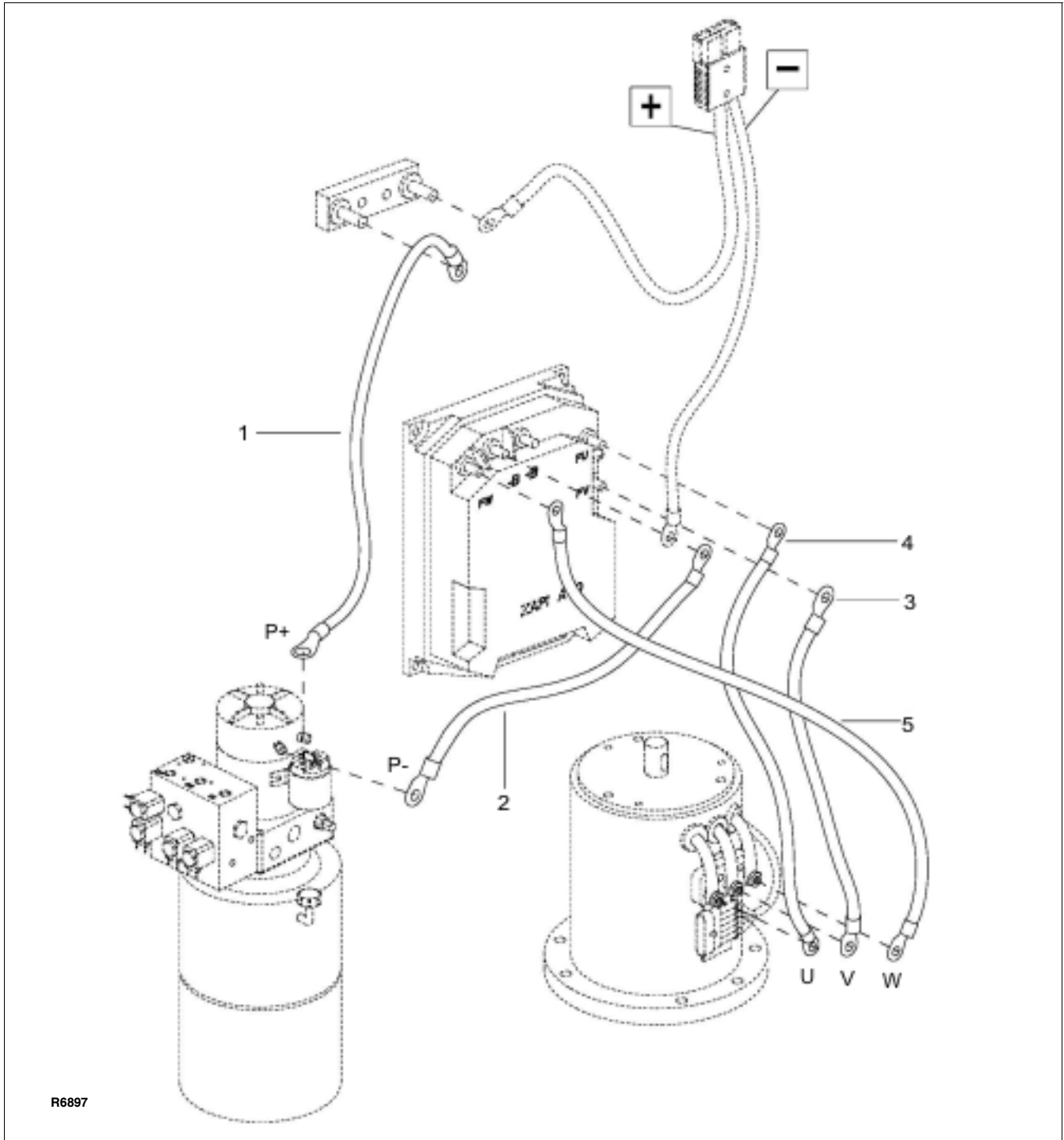

Figure 12-26 Wiring Cables

INDEX NO.	PART NO.	PART NAME	NO. REQD.
1	2320-530007-00	PUMP POWER CABLE +	1
2	2320-530006-00	PUMP POWER CABLE -	1
3	2320-530004-00	MOTOR CABLE V	1

INDEX NO.	PART NO.	PART NAME	NO. REQD.
4	2320-530003-00	MOTOR CABLE U	1
5	2320-530005-00	MOTOR CABLE W	1

NOTES

BLUE GIANT[®]
BLUE GIANT EQUIPMENT CORPORATION

Corporate 410 Admiral Blvd
Mississauga, ON, Canada L5T 2N6
t 905.457.3900 f 905.457.2313

USA 6350 Burnt Poplar Road
Greensboro, NC 27409
www.bluegiant.com