

BG2-126/144

The BG2 combines the advantages of a counterbalanced forklift with exceptional maneuverability. The result is a versatile task support vehicle that performs a broad range of material handling functions.

CAPACITY

- 2,000 lb (907 kg) at 24" LC on forks
- 300 lb (136 kg) operators compartment

BATTERY INFORMATION

- Minimum battery weight: 700 lb (318 kg)
- Compartment dimensions: 32" x 11" x Open
- Connector: Anderson 175 Grey – A-11

MAXIMUM LIFT HEIGHT

- 132" operator platform, 126" forks

MAXIMUM SPEED

- **TRAVEL:** Variable from 0 mph to 4.5 mph
- **LIFT:** Up to 42 fpm

WEIGHT

- 3,500 lb (1,588 kg)

TIRES / WHEELS

- **DRIVE:** (1) 9" x 3" polyurethane
- **STABILITY:** (2) 3" x 2" polyurethane
- **LOAD WHEELS:** (2) 6.5" x 4.7" polyurethane

ELECTRICAL

- Dual 24-volt ZAPI ACO travel and power steering controllers
- LCD dashboard displays hour meter, battery state, travel speed, and travel direction indicator
- AC drive motor
- Low-maintenance brushless design
- Selectable travel speed settings

BRAKES

- Regenerative braking when coasting and plug braking
- Electromagnetic parking brake

OPERATION / CONTROLS

- Ergonomic fingertip control for travel, lift, and lower functions
- Roomy operator compartment with ergonomic floormat, forward and backrest cushion
- Retractable compartment guard rails keep the operator secure
- On/off key switch and horn



MAST

- Heavy-duty I-beam design
- Steel mast channels and side mounted lift cylinders

CHASSIS

- Three-point chassis design
- 180° drive motor steering arc
- Powerhead mounted stability casters mounted on powerhead

STANDARD EQUIPMENT

- Non-marking tires
- Rear flashing light
- Battery compartment rollers
- 42" forks with pallet clamp
- Overhead guard

OPTIONAL EQUIPMENT

- 12-volt accessory power supply
- 24-volt industrial battery
- 24-volt external charger

BG2 DIMENSIONS

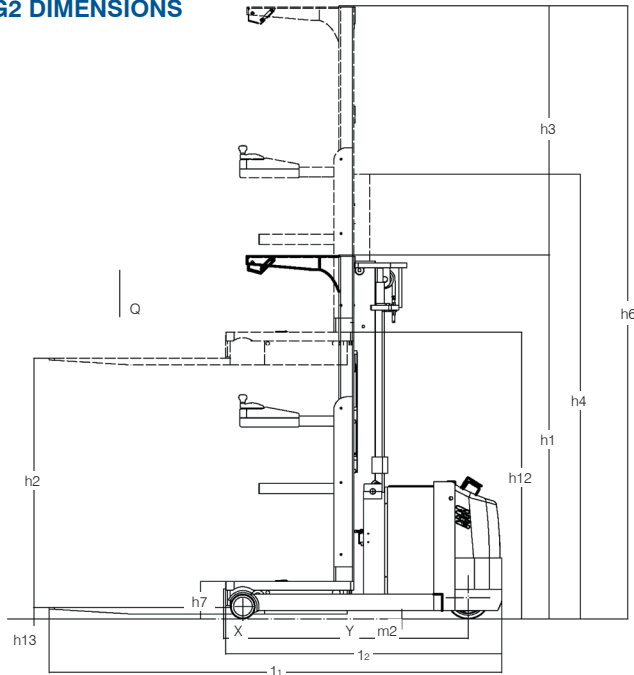

h7 = 8.75" lowered operator platform height

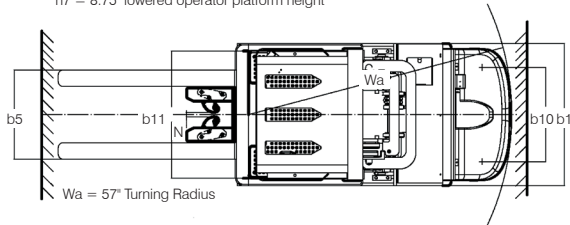

OPERATOR CONTROLS



Left Hand
360° Tiller Steering



Right Hand
Travel, Lift, Lower, Key
Switch and Controls

| Model# | Mast | Lift Height | | Col Height | | Extended Height | | Overall Width | | Overall Length | | Weight (Chassis Only*) | |
|---------|-----------|-------------|---------|------------|---------|-----------------|---------|---------------|-------|----------------|---------|------------------------|----------|
| | | h2 + h3 | 3,200mm | h1 | 2,273mm | h4 | 5,359mm | b3 / b1 | 864mm | L1 | 2,743mm | | |
| BG2-126 | Two Stage | 126" | 3,200mm | 89.5" | 2,273mm | 211" | 5,359mm | 34.0" | 864mm | 108.0" | 2,743mm | 2,610 lb | 1,184 kg |
| BG2-144 | Two Stage | 144" | 3,658mm | 94" | 2,388mm | 230" | 5,842mm | 34.0" | 864mm | 108.0" | 2,743mm | 3,800 lb | 1,724 kg |

* Estimated shipping weight without battery.



Corporate 410 Admiral Blvd
Mississauga ON L5T 2N6
t 905.457.3900 f 905.457.2313

USA 6350 Burnt Poplar Rd
Greensboro, NC 27409
www.bluegiant.com

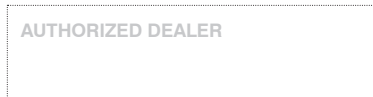

Blue Giant offers a full line of dock levelers, dock safety equipment, seals and shelters, accessories, ergonomic and scissor lift equipment and industrial trucks. Concurrent with our continuing product improvement program, specifications are subject to change without notice. Please contact Blue Giant for latest information. Some features illustrated may be optional in certain market areas.