



AIRFLOW HVLS FANS

# AirFlow HVLS Fans

Swift III Direct Drive Series  
16' to 24' Diameter



## Low on Cost, High on Performance

- Operates for less than a dollar a day
- Optimizes energy performance wherever installed
- Lowers perceived temperatures by up to 15°F
- Increase efficiency and lower run times of existing HVAC systems
- Increases employee comfort and productivity
- Compatible with Blue Giant AutoPilot multi-fan controller for added functionality

## Applications

- Warehouses
- Manufacturing facilities
- Auto dealerships
- Agriculture
- Retail facilities
- Gyms
- Places of worship

## Three-Blade Power

- Available blade sizes of 16' to 24'
- Innovative and aerospace-inspired blade design moves more air with less energy
- Three-airfoil system keeps employees comfortable and productive in small to medium-sized facilities
- Superior airflow distribution
- A cost-effective alternative to air conditioning
- Reduces condensation, corrosion and mold
- Silent operation

**BLUE GIANT**®

## Standard Features

### Custom-Engineered Airfoils

3 STOL-inspired extruded aluminum airfoils with wing tips, contoured for maximum air movement and redirect outward airflow into downward airflow.

### Wingtips

Decreases vortexes and makes air flow more efficient.

### Motor and Environmentally Durable Chassis

Direct drive system allows this fan to operate incredibly quiet. Totally enclosed direct drive, IP65 rated ECM motor (230/1/60; 230/3/60; 460/3/60).

### Extension Bar

Different sizes available to suit site layout and requirements.

### Warranty

5 year: Motor; 1 Year Electronics; Lifetime: Airfoil and Hub.

### Controls

Options include single fan, multiple fan, digital, and building integration.



**Swift III**

BLUE GIANT SERIES	AIRFOIL		MOTOR					MAX EFFECT DIA. ft.		INSTALLED WEIGHT lb	DIAMETER		DROP HEIGHT		MODEL
	NUMBER OF	FINISH	DRIVE TYPE	TYPE	RATING	HP	RPM	COOLING	HEATING		R	Z	R	Z	
Swift III	3	Anodized	Direct Drive	ECM	IP65	1.35	73	80	160	255	16 Ft.	4.9 m	30"	40"	<b>BGS3-1649</b>
							55	90	180	260	18 Ft.	5.5 m	33"	43"	<b>BGS3-1855</b>
							50	100	200	265	20 Ft.	6.1 m	36"	45"	<b>BGS3-2061</b>
							43	120	240	280	24 Ft.	7.3 m	44"	49"	<b>BGS3-2473</b>

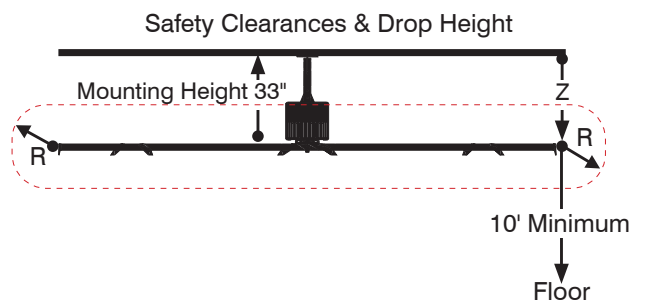
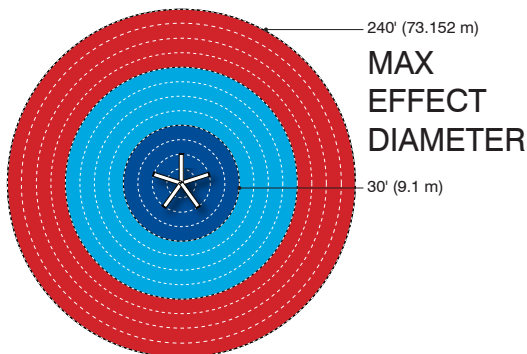

**BLUE GIANT**  
BLUE GIANT EQUIPMENT CORPORATION

**Corporate** 410 Admiral Blvd  
Mississauga, ON, Canada L5T 2N6  
t 905.457.3900 f 905.457.2313

**USA** 6350 Burnt Poplar Road  
Greensboro, NC 27409  
[www.bluegiant.com](http://www.bluegiant.com)

AUTHORIZED DEALER

Blue Giant offers a full line of dock levelers, dock safety equipment, seals and shelters, accessories, ergonomic and scissor lift equipment and industrial trucks. Concurrent with our continuing product improvement program, specifications are subject to change without notice. Please contact Blue Giant for latest information. Some features illustrated may be optional in certain market areas.