

# BGDSC HEAD CURTAIN DOCK SEAL

## FEATURES AND SPECIFICATIONS

Generally designed to suit 8' wide x 10' high door openings. The BGDSC has a full width head curtain. Two foam side pads close the gap between the building wall and the vehicle, keeping internal temperatures level while keeping weather-related hazards out.

Standard units seal trailers 12' to 13.5' high on a typical 4' dock height.

### STANDARD FEATURES:

- 10" projection
- 22 oz. Hi-Tear vinyl base fabric
- High visibility 24" yellow guide stripe
- Waterproof wraparound design with vapor barrier
- Compression release holes
- Condensation draining vents
- 99% memory foam
- Galvanized mounting hardware

For maximum value and performance, the BGDSC can be constructed from our premium durability fabrics (see chart for materials, weights, and available colors).

### ADDITIONAL OPTIONS INCLUDE:

- Full width head curtain that can be raised and lowered to suit a broad range of trailer heights
- Adjustable with ropes and pulleys
- 4", 8", or 16" wear flaps / pleats to suit site requirements
- Hook and loop split that allows the curtain to be adjusted even after the truck has docked
- 4" full foam face pad with hook and loop split to enable a tighter seal
- Pressure-treated lumber
- PVC drop curtain
- Competitive split, no hook and loop or pulleys

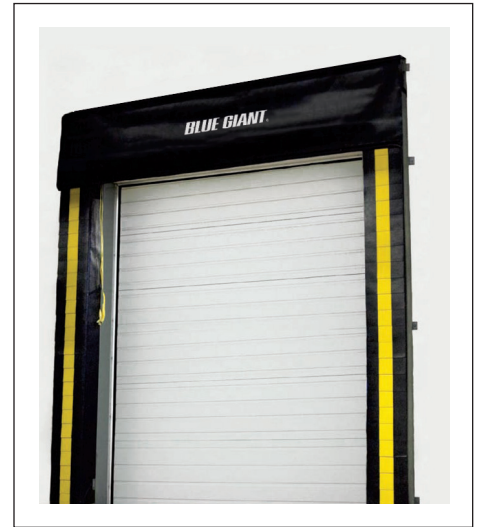
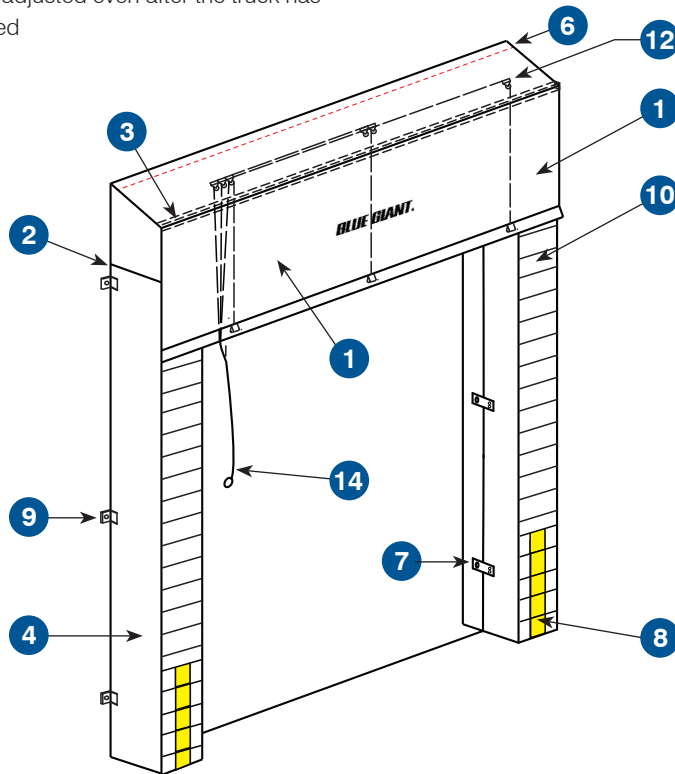

BGDSC Head Curtain Dock Seal

### FABRIC AND COLOR SELECTION:

22oz Hi-Tear Vinyl	■	■	■	■
40oz Hi-Tear Vinyl	■	■	■	■
50oz Hi-Tear Vinyl	■			
16oz Hi-Performance Hypalon	■			
40oz Hi-Performance Hypalon	■			

No.	DESCRIPTION
1	Adjustable head curtain*
2	End cap
3	Square tube curtain support
4	Side pad
5	Wood backboard kiln dried †
6	2" x 4" curtain mounting board (optional flat bar) †
7	Flat bracket
8	4" x 24" yellow guide stripe
9	Angle bracket
10	Wear flaps / pleats *
11	Sealing edge †
<b>If Adjustable Head Curtain option selected:</b>	
12	Pulleys
13	6" aluminum rope cleat †
14	Curtain retraction cord*

\*Some items displayed may be optional  
† Not shown on drawing

**BLUE GIANT**  
BLUE GIANT EQUIPMENT CORPORATION

Corporate 410 Admiral Blvd  
Mississauga ON L5T 2N6  
t 905.457.3900 f 905.457.2313

USA 6350 Burnt Poplar Road  
Greensboro, NC 27409  
[www.BlueGiant.com](http://www.BlueGiant.com)

AUTHORIZED DEALER

Blue Giant offers a full line of dock levelers, dock safety equipment, seals and shelters, accessories, ergonomic and scissor lift equipment and industrial trucks. Concurrent with our continuing product improvement program, specifications are subject to change without notice. Please contact Blue Giant for latest information. Some features illustrated may be optional in certain market areas.