

INSTALLATION INSTRUCTIONS

WARNING

Do not install, operate and/or service this leveler until you have read and understood all of the safety information and instructions contained herein and on the leveler.

Do not work under or around leveler being installed without first placing adequate barriers to positively prevent vehicle traffic from entering the work area.

Keep hands and feet clear of dock leveler pinch points.

Do not work beneath dock leveler without engaging maintenance strut.

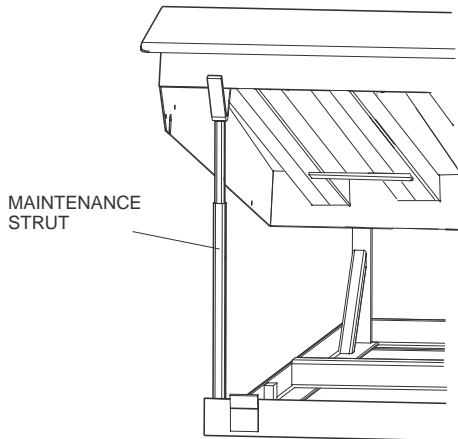

Remove & discard current hold down assembly.

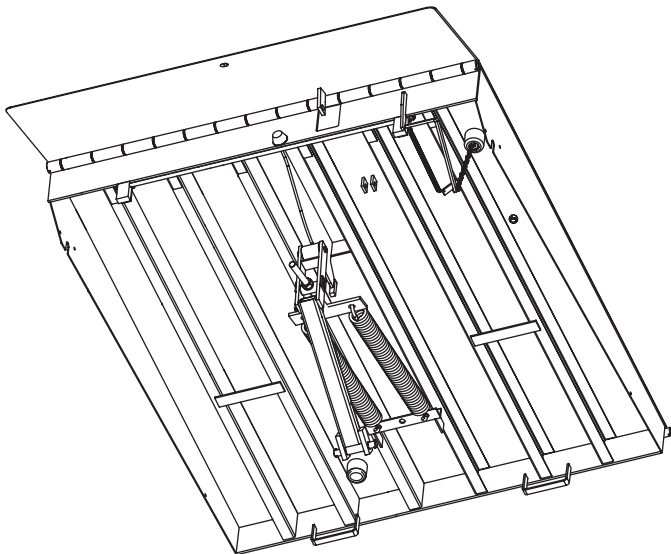

Underside of Mantis Mechanical Dock
(after removal of old Multi-link Kit & Shock Absorber if carried)
LIP EXTENDED FOR VIEW ONLY, ENGAGE MAINTENANCE STRUT BEFORE STARTING ANY WORK

Step A.

Visually inspect your specific dock to determine where the most practical place for your new hold down assembly should be installed. The dock leveler's new hold down assembly would be in the same proximity of the removed one where the use of the cup for the pull chain can be utilized (**item A figure 1**). In some circumstances the position of the existing cup cannot be used and will have to be removed and patched. Included in the retrofit kit is a chain cup for this reason.

Step .B

Docks with a Fall Safe / Safety Legs feature can interfere with the new hold down assembly. The installer should make sure the Safety Legs do not make any contact with the hold down kit. This can either be done by marking the operating range of the legs or by tacking the Safety Legs in place to make sure that there is no possibility of the hold down kit getting hit (**item B figure 1**).

Step .C

The hold down kit should be installed between the decks beams near the front of the dock parallel with the chain cup (**item C figure 1**) for docks with safety legs this would be as close to the front where the Legs do not interfere. For docks with no Safety Legs the hold down kit would be installed 3"- 4" from the front deck plate (**item D figure 1**).

Step .D

When the best area to mount the hold down kit has been determined and all operating interferences of other parts of the dock leveler has been taken into consideration the installer can weld the mounting plate on for the hold down system. Weld the plate as described in the illustration. Weld all around and mount the hold down assembly with the 4 nylon nuts provided (**item E figure 1**).

Step .E

For majority of the dock levelers the deck beam will have to be notched out for the hold down assembly to be installed. The base of the hold down strap kit has mounting holes where left to right adjustment is possible and so the decks beam does not need to have a large notch where the decks structure might be affected (**item F figure 1**).

Step .F

Insert the tension spring through the tension strap and run straight to the back of the docks back panel for 6' to 8' long docks or between 1' to 2' from the back panel for 10' to 12" long docks and mark where the tension spring bracket will be welded. Weld the tension spring bracket to the bottom of the deck where it will hang down and hook in tension spring (**item G figure 2**).

Step .G

Install the break handle bar and weld the break handle guide bracket in a position where it will hold the bar straight (**item H figure 2**).

Step .H

Assemble the pull chain and thread through the chain cup through the top of the deck to the break handle bar. For 8' to 12' long docks a brake handle extension bar and hardware has been added in order to reach the chains cup (**item I figure 2**).

Step .I

Cut the tie strap on the hold down assembly and pull down to an area where the strap holding bracket can either be welded to the frame or lag bolted to the concrete foundation directly below the hold down assembly (**item J figure 2**).

Step .J

Adjust the dock leveler's lift height by threading the amount of hold down strap through the bracket. The more of the strap you thread through the less the lift height will be for the dock leveler (**item K figure 2**).

Step .K

Adjust the break caliper for the hold down strap by tightening the adjustment nut. If the break is too tight the dock will not deploy when the chain is pulled and over time will wear out the strap. If the brake is too loose, the dock will not remain in the stored position and will spring back to the deployed position (**item L figure 2**).

INSTALLATION INSTRUCTIONS

- E** Weld the Mounting Plate for the Hold Down Strap assembly after determining the best place where there will be no operating interference.

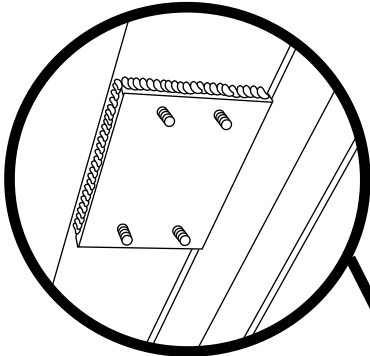

- F** When it is determined the best place to mount the hold down assembly notch out the decks beam with a torch just enough where there will be no interference.

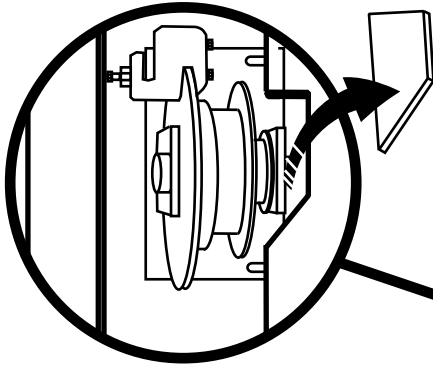

- D** Mount Hold Down Assembly away from the operating range of the Fall Safe / Safety Legs.
Docks without Fall Safe / Safety Legs
Mount 3" to 4" from the front deck plate

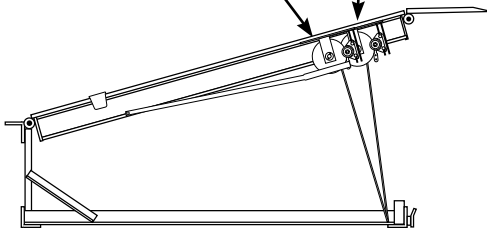

- A** Ensure the pull chain cup is parallel with the hold down assembly. If using the existing cup is not possible you must install the cup provided and patch up the un-usable one.

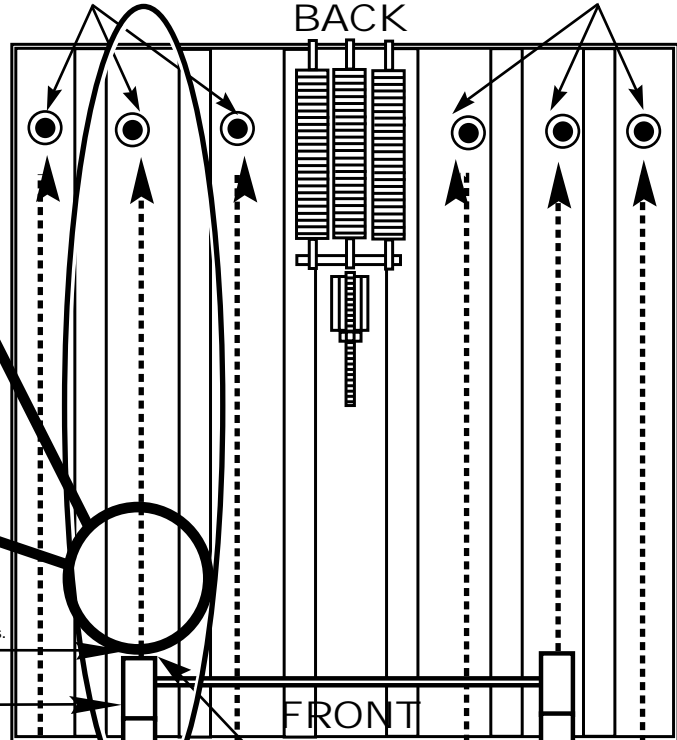

- B** Tack weld or mark the operating area of the fall safe / safety legs to avoid interference with the hold down kit.



- C** Mount the hold down assembly between 2 beams (parallel to the chain cup if possible) where there will be no interference with any of the other parts of the dock leveler.

CYLINDER AND BRACKET ASSEMBLY DRAWING

G

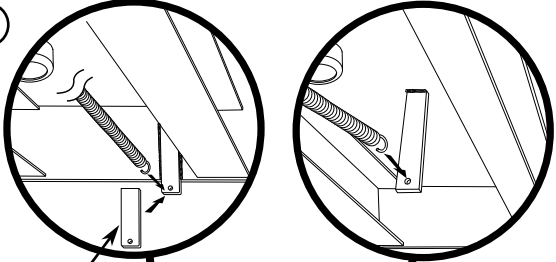

For 6' long docks weld the Tension Spring Bracket to inside back deck plate and hook in Tension Spring.

For docks longer than 6' weld the Tension Spring Bracket 43-3/4" from the mounting plate as shown.

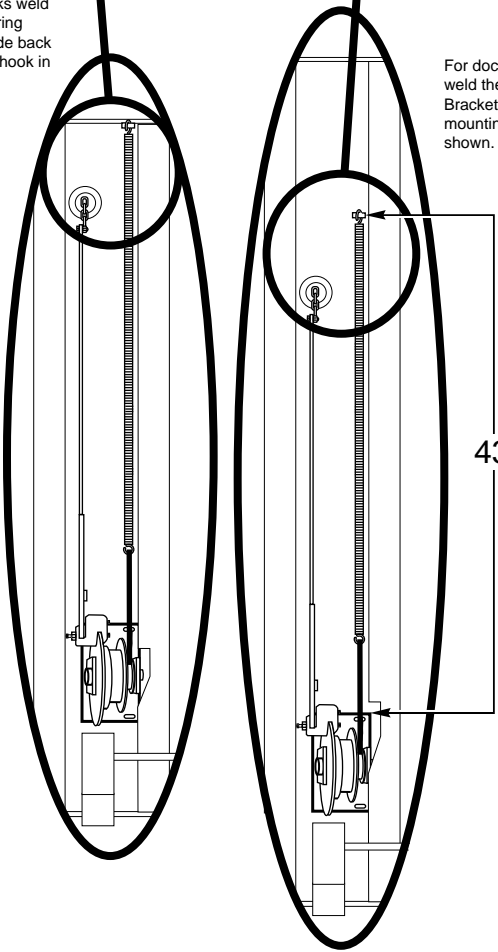

43 3/4"

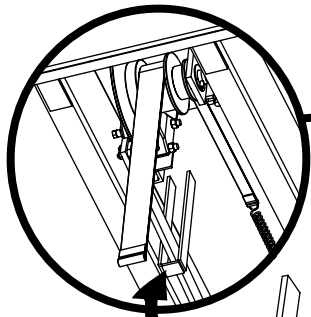

H

Install the break handle bar and weld the break handle guide bracket in a position where it will hold the bar straight.

I

When Installing the Break Release Bar ensure that there is easy up and down movement. In some circumstances a longer chain or shortening of the bar may be required.

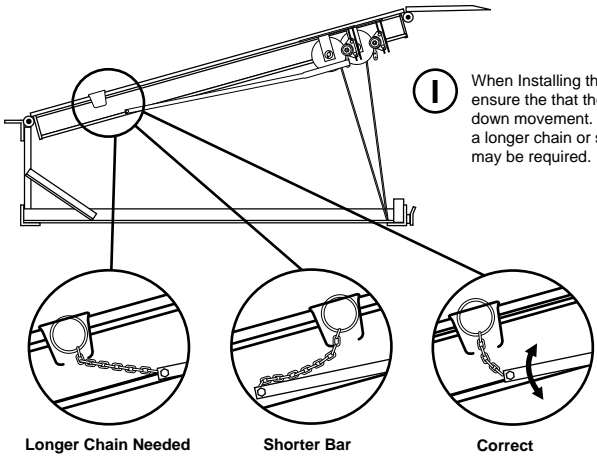

Longer Chain Needed

Shorter Bar

Correct

K

Adjust the levelers lift height by threading the amount of hold down strap through the bracket

J

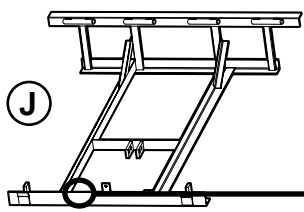

Weld Hold Down Strap Bracket to inside frame



Lag Bolt Hold Down Strap Bracket to concrete foundation

Break lock nut

Break Adjusting nut

L

Please refer to Written Instructions Regarding Adjusting of the Break Assembly.